

**DRAFT**

**DIGITAL RANGE TRAINING SYSTEMS (DRTS)  
PERFORMANCE SPECIFICATION**



**U.S. Army Program Executive Office for  
Simulation, Training and Instrumentation (PEO STRI)  
12211 Science Drive  
Orlando, FL 32826-3276**

Engineering:

Prepared By: \_\_\_\_\_

Hien Pham, Nicole Steib, Lester Marti  
Systems Engineer, PdM LTS

Concurrence: \_\_\_\_\_

James Todd  
Chief Engineer, PdM LTS, FOT

Acquisition Logistics:

Prepared By: \_\_\_\_\_

Gary Stevenson  
Lead Acquisition Logistician  
LTS, FOT

Concurrence: \_\_\_\_\_

Matt Brothers  
Product Support Manager, PdM

Distribution Statement A:  
Approved for Public Release, Distribution is Unlimited

### Revision History

Date	Version	Author	Paragraph	Revision Description
06 Oct 2021	1.0	DRTS Team	All	New DRTS Specification

# TABLE OF CONTENTS

<b>1. Digital Range Training Systems (DRTS)</b> .....	<b>1</b>
<b>1.1. Scope</b> .....	<b>2</b>
<b>1.2. Overview</b> .....	<b>2</b>
<b>2. Applicable Documents</b> .....	<b>3</b>
<b>2.1. Government Regulations, Directives, and Instructions</b> .....	<b>3</b>
<b>2.2. Military Specifications, Standards, and Handbooks</b> .....	<b>3</b>
<b>2.3. Other Government Documents</b> .....	<b>4</b>
<b>2.4. Non-Government Standards and Publications</b> .....	<b>5</b>
<b>3. Requirements</b> .....	<b>6</b>
<b>3.1. General Performance</b> .....	<b>6</b>
3.1.1. Systems Start, Shut Down and Restart Requirements .....	6
3.1.2. Scalability .....	7
3.1.3. Availability .....	7
<b>3.2. Control Tower</b> .....	<b>7</b>
3.2.1. General Design Considerations .....	7
3.2.2. Control Tower System Performance .....	8
3.2.3. Exercise Management .....	17
3.2.4. Video System Suite (VSS) .....	23
3.2.5. Ingest Workstation (WS) .....	23
3.2.6. Hand-Held Target Control Function .....	24
3.2.7. Scenario Development Tool (SDT) .....	24
3.2.8. Range Data Editor (RDE).....	25
<b>3.3. AAR Facility</b> .....	<b>26</b>
3.3.1. AAR Presentation Workstation (PWS) Podium .....	26
3.3.2. Theater Audiovisual Equipment .....	26
<b>3.4. Field Support Equipment (FSE)</b> .....	<b>27</b>
<b>3.5. Target System</b> .....	<b>28</b>
3.5.1. Targetry System (TS) General .....	28
3.5.2. Target Types .....	29
3.5.3. Battlefield Effects Simulators (BES).....	29
<b>3.6. AWSS</b> .....	<b>29</b>
<b>3.7. Field Cameras</b> .....	<b>29</b>
<b>3.8. Range Digital Communications System (RDCS)</b> .....	<b>30</b>
<b>3.9. Player Units (PUs)</b> .....	<b>36</b>
3.9.1. PU Coverage Area .....	36

<b>3.10. Firmware</b>	<b>37</b>
<b>3.11. Electromagnetic</b>	<b>37</b>
3.11.1. Electromagnetic Environmental Effects (E3)	37
3.11.2. Electromagnetic Compatibility (EMC)	37
3.11.3. Electromagnetic Radiation Hazards (EMRADHAZ)	38
3.11.4. Non-Developmental Items (NDI) and Commercial Items	38
<b>3.12. Cybersecurity (CS)</b>	<b>38</b>
<b>3.13. Security</b>	<b>39</b>
3.13.1. System Access	40
3.13.2. Portable Electronic Devices (PEDS)	41
<b>3.14. System Safety</b>	<b>43</b>
3.14.1. Environmental Safety	43
3.14.2. Electrical Safety	43
3.14.3. Hazardous Materials	43
3.14.4. Personnel Safety	44
3.14.5. Mechanical Safety	44
3.14.6. Antenna Safety	44
3.14.7. Battery Box Design Safety	45
3.14.8. Electronic and System Protection	45
3.14.9. Environmental	46
3.14.10. Indoor HVAC Controlled Facility Conditions	46
3.14.11. Outdoor Conditions	47
<b>3.15. Logistics</b>	<b>48</b>
3.15.1. Maintenance Concept	48
<b>3.16. Facilities</b>	<b>51</b>
<b>3.17. Reliability</b>	<b>51</b>
<b>3.18. Maintainability</b>	<b>51</b>
<b>3.19. Human Engineering</b>	<b>51</b>
<b>4. Verification</b>	<b>52</b>
<b>4.1. DRTS General Performance Requirements</b>	<b>58</b>
4.1.1. Systems Start, Shut Down and Restart Requirements	58
4.1.2. Scalability	59
4.1.3. Availability	59
<b>4.2. Control Tower</b>	<b>59</b>
4.2.1. General Design Considerations	59
4.2.2. Control Tower System Performance	61
<b>4.3. Electromagnetic</b>	<b>64</b>
4.3.1. Electromagnetic Environmental Effects (E3)	65
4.3.2. Electromagnetic Compatibility (EMC)	65

4.3.3.	Electromagnetic Radiation Hazards (EMRADHAZ) .....	65
4.3.4.	Non-Developmental Items (NDI) and Commercial Items .....	65
<b>4.4.</b>	<b>Cybersecurity (CS).....</b>	<b>65</b>
<b>4.5.</b>	<b>Security.....</b>	<b>66</b>
4.5.1.	System Access .....	69
4.5.2.	Portable Electronic Devices (PEDS) .....	70
<b>4.6.</b>	<b>System Safety .....</b>	<b>71</b>
4.6.1.	Environmental Safety .....	72
4.6.2.	Electrical Safety .....	72
4.6.3.	Hazardous Materials .....	72
4.6.4.	Personnel Safety.....	73
4.6.5.	Mechanical Safety.....	73
4.6.6.	Antenna Safety .....	73
4.6.7.	Battery Box Design Safety .....	74
4.6.8.	Electronic and System Protection .....	74
4.6.9.	Environmental .....	75
4.6.10.	Indoor HVAC Controlled Facility Conditions.....	75
4.6.11.	Outdoor Conditions .....	76
<b>4.7.</b>	<b>Logistics .....</b>	<b>80</b>
4.7.1.	Maintenance Concept .....	80
<b>4.8.</b>	<b>Facilities.....</b>	<b>83</b>
<b>4.9.</b>	<b>Reliability .....</b>	<b>84</b>
<b>4.10.</b>	<b>Maintainability .....</b>	<b>84</b>
<b>4.11.</b>	<b>Human Engineering .....</b>	<b>84</b>
<b>5.</b>	<b>Abbreviations and Acronyms .....</b>	<b>85</b>

## **1. Digital Range Training Systems (DRTS)**

The Digital Range Training System (DRTS) provides advanced instrumentation specifically required for live fire gunnery training and qualification with the Abrams, Bradley, Stryker/MGS and Apache Aircraft on larger mounted maneuver Instrumented "Digital" Ranges. DRTS provides crew, section, platoon and company training and qualification capabilities above and beyond any other range in the Army inventory. Dismounted Tracker (DMT) provides situational awareness during section, platoon, and company training to track movement of troops on ground on the entire range complex. These ranges interface with the tactical vehicles through an Integrated Player Unit Recorder (IPUR) or Smart Onboard Data Interface Module (SMODIM) to provide both real-time feedback to leaders and rapid development of complete After Action Reviews (AARs) and Take Home Packages (THPs). These AAR THPs include synchronized Thru-Sight Video (TSV) from the Commander/Gunner sights, crew camera video from inside the vehicles, thermal field camera video from the range cameras and internal crew audio for a complete evaluation tool. Ten of these DRTS ranges also incorporate Aerial Weapons Scoring System (AWSS) to interface with Aviation and Unmanned Aerial System gunnery training and qualification in a similar manner. The five standard training ranges identified utilize all available combat systems capabilities and digitally integrate them to manage all forces undergoing crew through collective live-fire training and qualification: Digital Multi-Purpose Range Complex (DMPRC) supports all gunnery tables and Combined Arms Live fire Exercise (CALFEX) for Armor, Infantry and Aviation; Digital Multi-Purpose Training Range (DMPTR) supports crew and section qualification for Armor and Infantry; Battle Area Complex (BAX) supports crew through company CALFEX for Stryker & Infantry Brigade Combat Team (SBCT/IBCT); Digital Air Ground Integration Range (DAGIR) supports all gunnery tables and CALFEX for Armor, Infantry and Aviation platforms; Aerial Gunnery Range (AGR) at Fort Bragg supports crew through Company CALFEX for manned/unmanned aviation platforms.

To provide the necessary Aviation gunnery training with Instrumented Range capabilities, the DRTS system can be fully integrated with Aerial Weapon Scoring System (AWSS) and the Aviation player unit to support Aviation units on a DAGIR. Other Instrumented Ranges (IR) / DRTS Range types may also support integration with the portable AWSS and Aviation player units in support of Aviation gunnery. DRTS will have the embedded capability to provide a gateway to the Constructive and Virtual training environments.

The DRTS system is a product of the Live Training Transformation (LT2) family. The LT2 Product Line is a "Family of Systems" utilizing the Common Training Instrumentation Architecture (CTIA) Compliant Components. The common components include standard interfaces to Virtual and Constructive simulation systems, Army Battle Command Systems (ABCS), Army Training Information Architecture (ATIA), targetry systems, and other training systems that require interoperability with LT2 Product Line systems. CTIA provides reusable components to implement a common Objective Instrumentation System (OIS) for the Maneuver Combat Training Centers (MCTC)

home-station training, Integrated Military Operations on Urbanized Terrain (MOUT) Training System (I-MTS) facilities, and the IR / DRTS.

### 1.1. Scope

This specification establishes the performance and validation requirements for the DRTS program. The requirements include the following major components:

- a. Control Tower
- b. After Action Review (AAR)
- c. Integrated Player Unit Recorder (IPUR)
- d. Target Systems
- e. Aerial Weapons Scoring System (AWSS)
- f. Exterior Video Cameras
- g. Aviation
- h. Range communications for voice and data transmissions
- i. Battlefield Effects Simulators (BES)
- j. Single Channel Ground-Air Radio System (SINGGARS)
- k. Blue Force Tracker (BFT)

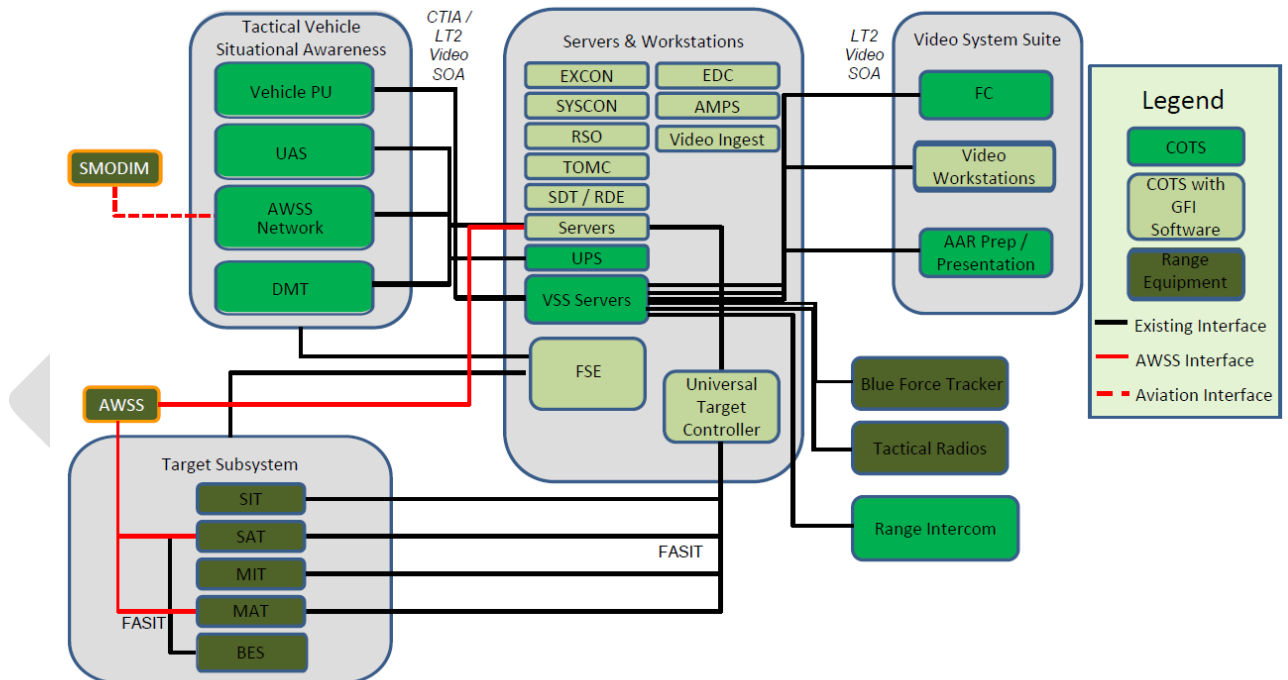

Figure 1: System Diagram

### 1.2. Overview

DRTS provides real time monitoring, data collection, analysis, and review. Data shall be collected while monitoring, controlling, and recording the Force on Target (FOT) engagements that occur in the battlefield environment. The DRTS gateway to the

constructive and virtual world shall be through the Common Training Instrumentation Architecture (CTIA). The following DRTS ranges are defined in the Department of the Army Training Circular (TC) 25-8. Training Range.

- a. Digital Multi-Purpose Range Complex (DMPRC)
- b. Digital Multi-Purpose Training Range (DMPTR)
- c. Battle Area Complex (BAX)
- d. Digital Air/Ground Integration Range (DAGIR)
- e. Aerial Gunnery Range (AGR)

This product line of instrumented ranges provides enhanced training data collection for AAR, utilization of interfaces compliant with the CTIA, and Future Army System of Integrated Targets (FASIT) to represent realistic threats.

## 2. Applicable Documents

In the event of a conflict between documents referenced herein and the contents of this Performance Specification, the contents of this Performance Specification shall be the governing requirement.

### 2.1. Government Regulations, Directives, and Instructions

Document Number	Document Title
Army Regulation 25-2	Cybersecurity (CS)
09-EC-M-0010	Wireless Security Standards
DODD 5000.1	The Defense Acquisition System
DODI 8510.01	Risk Management Framework (RMF) for Department of Defense (DOD) Information Technology (IT)

**Table 1: Government Documents**

### 2.2. Military Specifications, Standards, and Handbooks

The following specifications, standards, and handbooks form a part of this document to the extent specified herein.

Number	Title
MIL-A-89007	Arc Digitized Raster Graphics (ADRG)
MIL-STD-188-220	Digital Message Transfer Device Subsystems
MIL-STD-810G	Environmental Engineering Considerations And Laboratory Tests
MIL-STD-461	Requirements for Control of Electromagnetic Interference Characteristics of Subsystems and equipment
MIL-STD-1275	DOD Characteristics of 28 Volt DC Electrical systems in military vehicles
MIL-STD-1472G	DOD Design Criteria Standard: Human Engineering
MIL-STD-1474	Noise Limits

MIL-STD-1553	Digital Time Division Command/Response Multiplex Data Bus
MIL-STD-2301	Computer Graphics Metafile (CGM) Implementation Standard
MIL-STD-2401	DOD Standard Practice, World Geodetic System (WGS 84)
MIL-STD-2525A	Military Symbology
GPS SPS PS 5 <sup>th</sup> Edition	Global Positioning System Standard Positioning Service Performance Standard

**Table 2: Specifications, Standards and Handbooks**

### 2.3. Other Government Documents

The following other Government documents, drawings, and publications form a part of this specification to the extent specified herein.

<b>Document Number</b>	<b>Document Title</b>
PRF-PT-769	Visual System Suite (VSS) Performance Specification
PRF-PT-765	Player Unit (PU) Specification
LT2 Publication Version 3.0	Video Live Training Transformation (LT2) Service Oriented Architecture (SOA) Interface Control Document (ICD)
PRF-PT-00468	FASIT Performance Specification
ICD.FASIT.SYS	FASIT System Devices Interface Control Document
ICD.FASIT.AUDIO	FASIT Audio Devices Interface Control Document
ICD.FASIT.ESD	FASIT Engagement Scoring Devices Interface Control Document
ICD.FASIT.PD	FASIT Presentation Devices Interface Control Document
ICD.FASIT.PYRO	FASIT Pyrotechnic Device Interface Control Document
ICD.FASIT.RIM	FASIT Range Interface Module Interface Control Document
ICD.FASIT.RP	FASIT Representation Devices Interface Control Document
DMPRC-HOOD-BES-TARGET-ICD	BES Target Interface Control Document
PRF-PT-767	Dismounted Tracker (DMT) Performance Specification
PRF-PT00588	Interface Standard for the Multi-Function Vehicle Port (MFVP)
ICD SA16575	Independent Thermal Viewer (CITV) (Abrams)
ICD 19200-12956704	Improved Bradley Acquisition Subsystem (IBAS) Commander's Independent Viewer (CIV) (Bradley)
ICD 12991282(A)	Second Generation Forward Looking Infrared Radar (2nd Generation FLIR)

ICD SA16575	Gunner's Primary Sight-Line of Sight (GPS-LoS) captured through the Gunner's Primary Sight Extension (GPSE) on the Abrams
TM-VPU-1553-IDD	Player Unit Interface Design Document (IDD) for the Tactical Micro Player Unit 1553 Interface, version 1, 11 Nov 13
(None)	DRTS System Security Plan (SSP)
Operational Requirements Document (ORD), dated 27 Sept 1999	Digital Multi-Purpose Range Complex (DMPRC)
OASD(C3I) 5 <sup>th</sup> Edition	Global Positioning System (GPS) Positioning Service Performance Standard

**Table 3: Other Government Documents**

#### 2.4. Non-Government Standards and Publications

The following documents form a part of this document to the extent specified herein.

Standard Number	Standard Title
29 CFR 1910	Occupational Safety and Health Standards
ATA 300	Specification for Container Requirements
ANSI/NFPA 70-2002	National Fire Protection Association's National Electrical Code
IEEE-1394	IEEE Standard for a High Performance Serial Bus
IEEE 802.11	IEEE 802.11 series Wireless Local Area Network (WLAN) equipment
FIPS 140-2	Security Requirements for Cryptographic Modules FPA 70-2001
MPEG-2	ISO/IEC 13818-1:2000 Generic Coding of Moving Pictures and Associated Audio Information Systems
MPEG-4	ISO/IEC 14496 Coding Of Moving Pictures and Audio
MPEG-7	ISO/IEC JTC1/SC29/WG11 N5525 Multimedia Content Description Interface
NEMA 12 OR 13	National Electrical Manufacturers Association ratings for enclosures
09-EC-M-0010	Wireless Security Standards, Version 3.0, 2 January 2009

**Table 4: Non-Government Standards and Publications**

Copies of specifications, standards, and drawings may be obtained as directed by the Contracting Officer (PCO).

### **3. Requirements**

#### **3.1. General Performance**

This specification provides the performance requirements applicable to the complete DRTS system. The requirements for the Visual System Suite (VSS) and the Player Units (IPUR and DMT) are provided in sub-ordinate specifications as referenced in this document. The DRTS system shall be comprised of the appropriate hardware and software elements required to fulfill the requirements of this specification.

##### **3.1.1. Systems Start, Shut Down and Restart Requirements**

The System Start, Shut Down, and Restart requirements shall apply to components installed in the Control Tower, to include Aerial Weapons Scoring System (AWSS) Control Station Subsystem (CSS), DRTS servers, Communications Systems (i.e. Clearcomm, SINCGARS), SYSCON WSs, EXCON WSs, and any other evaluation room workstation (i.e. EDC), as well as After Action Review (AAR) components to include the Podium workstations (PWS), Take-Home Package WS, and CMUR Ingest WS.

###### **3.1.1.1. System Startup and Restart**

System startup refers to the start of the system or system components from a completely powered down condition to the last saved configuration. The restart process shall restore the system to the same functional condition prior to system restart. The DRTS system shall:

- a. Provide a full system startup of all components referenced in section 3.1.1 to include hardware (HW) and Operating System (OS).
- b. Have the capability to be in a full operational state (systems and sub systems) in 30 minutes or less from full system start.
- c. Have an Auto Start capability, which shall enable all Control Tower and AAR Building components to power up from a single location.
- d. Start all server and WS applications within 20 minutes from full system start up.
- e. Have all WSs ready for use in 1 minute or less from full system startup.
- f. Include all sub-system infrastructure as part of the startup process (i.e. IPUR, DMT, UAS, Field Cameras infrastructure).

Note: The individual DRTS Sub-Systems listed under 3.1.1.1f will be manually powered on.

###### **3.1.1.2. System Shut Down**

The DRTS system shall:

- a. Provide an orderly shutdown of all systems referenced in section 3.1.1.
- b. Have an Auto Shut-Down capability, which shall enable all Control Tower and AAR Building components to power down from a single location.
- c. Attain a powered-off condition within 20 minutes.
- d. Not lose any database or configuration data.
- e. Leave the system in a state that can be started.

### **3.1.2. Scalability**

The DRTS system shall be implemented in a modular and scalable manner to support the Department of the Army Training Circular (TC) 25-8. Training Range doctrine on the following range types/configurations:

- a. Digital Multi-Purpose Range Complex (DMPRC).
- b. Digital Multi-Purpose Training Range (DMPTR).
- c. Battle Area Complex (BAX).
- d. Digital Air/Ground Integration Range (DAGIR).
- e. Aerial Gunnery Range (AGR).

The modular implementation shall maximize common component reuse across the configurations and allow for scalable components additions to achieve range configuration capabilities.

### **3.1.3. Availability**

The DRTS system shall:

- a. Achieve an operational availability of 99%.
- b. Be capable of operating continuously for 22 days without a system restart.
- c. Enable Main Servers to be re-cycled after the 11<sup>th</sup> consecutive day of operation with either all data flushed or with no data loss.
- d. Sustain data due to loss of power, environmental control, or weather within the 11-day cycle.

## **3.2. Control Tower**

### **3.2.1. General Design Considerations**

The DRTS system shall:

- a. Utilize the Government Furnished Information (GFI) SW.
- b. Utilizes CTIA, LT2 Product Line components, and commercial products.
- c. Minimize specially developed SW or HW.
- d. Have visual SW displays that conform to the CTIA Common Graphical User Interface (GUI) Style Guide and Framework.
- e. Provide access to menus, icons, and other GUI devices through a pointing device and the keyboard ("hot keys" and function keys).
- f. Have visual displays with scroll bars, zoom, or drag hands to ensure all displayed data is viewable.
- g. Have operator error messages, which include the nature of the error, the correction method, and the name of the packages/object that generated the message.
- h. Display formatting text tips to augment operator's understanding of displays; for example, displaying data constraints, format, and units when pointer is over the field.
- i. Integrate displays through menus, icons, buttons, and other GUI devices.
- j. Have adjustable displays with operator palette control.
- k. Have default palettes that are recoverable.

- l. Have palettes (colors) annotated in the application such as standard colors for icons, symbology, event depiction, and other effects.
- m. Be capable of saving application configuration changes as preferences and recovering those preferences for later use.
- n. Have non-destructive display windows (i.e. the opening of an application shall not force the abnormal end of a running application).
- o. Have the capability to overlap displays without corrupting data (e.g. closing a window shall automatically restore the underlying display.)
- p. Refresh displays within 1 sec.
- q. Display Security Classification, date, and time at all times.
- r. Allow operators the option of displaying exercise time (time since start of exercise) and one of the following: local time, Coordinated Universal Time (UTC), or Greenwich Mean Time (GMT).
- s. Allow the time format be selectable at any time.
- t. Ensure the time in the system is traceable to UTC (GPS) or UTC maintained by the U.S. Naval Observatory.
- u. Have all servers and WSs compliant with the current DRTS System Security Plan (SSP).

### **3.2.2. Control Tower System Performance**

The DRTS Control Tower shall:

- a. Be equipped to conduct exercises at that fixed location.
- b. Enable all WSs the capability of executing all required Control Tower SW and functionality.
- c. Have all the servers and WS required to support the GFI DRTS SW.
- d. Have a 50% spare CPU and memory capacity for Servers and WS.
- e. Be in a network controller and relay environment.
- f. Contain all equipment required for hosting the Control Tower database including, AWSS CSS Real Time Processes (RTP), Aviation Data Translators (ADT), logging of exercise data, interfacing range components to the Range Digital Communications System (RDCS), the technical operations, maintenance SW, video/audio recording, and playback.
- g. Enable each WS to have the capability to create and read commonly available removable media (e.g. CD-R, CD-RW, and DVD-RW).
- h. Utilize media via industry standard parallel or serial interfaces (i.e. Small Computer Systems Interface (SCSI), Fire Wire (IEEE1394), and Universal Serial Bus (USB)).
- i. Ensure each WS has the necessary user input and display devices required to operate.
- j. Ensure all WSs and associated equipment shall support system security controls.
- k. Have headsets and distribution equipment for communicating with other WSs and radio systems.
- l. Have access to tactical/administrative radio systems via the WSs.

- m. Have display HW capable of displaying the exercise area (4km x 6km for DMPRC and 2.5km x 5km for other DRTS range types) 1:25,000 Arc Digitized Raster Graphics (ADRG) map at a 2.5X zoom-in.
- n. Have graphics cards capable of 3D graphics (e.g. rendering, texturing, and Z-buffering) using Commercial Off-The-Shelf (COTS) graphics formats (e.g. DirectX, OpenGL).
- o. Enable back-up and archival of data (Hard Drive or CD).
- p. Have printer(s) for graphics and text printout in black-and-white and color.
- q. Have a Weather Station capable of showing the Barometric Pressure, Wind Speed, Air Temperature, & Wind Direction.
- r. Integrate the GFI BFT/BFT2 and MIL-STD-188-220 or satellite terminals.
- s. Have the ability to interface with SINCGARS voice and Push-To-Talk (PTT) distribution.
- t. Have separate Uninterruptible Power Supplies (UPS) for all equipment or a single UPS with power conditioning as the source of all equipment power.
- u. Shall provide a UPS with enough backup power to execute an orderly power shutdown. (Orderly power shutdown is defined as successful if all data and states are saved as well as successful resumption of the training scenario from the point it was halted due to the loss of power.)
- v. Have the Audio/Video interfaces necessary to ingest aircraft recorded audio and video from the Aviation Workstation (AWS) for AAR.

### **3.2.2.1. Workstations (WS)**

The DRTS WSs shall:

- a. Control and manage the DRTS components.
- b. Be configurable as a Technical Operations and Maintenance Control (TOMC) WS.
- c. Be configurable as a Range Safety Officer (RSO) WS.
- d. Be configurable as a System Control (SYSCON) WS.
- e. Be configurable as a Crew Evaluator WS (CEWS).
- f. Be configurable as a Presentation WS (PWS).
- g. Be configurable as a Take Home Package (THP) WS.
- h. Be configurable as an Ingest WS, as required.
- i. Be configurable to connect with interface devices such as mouse, keyboard, joysticks or any other required devices at the WS desks.

### **3.2.2.2. Operational Mode**

The DRTS Control Tower shall:

- a. Be modular and expandable.
- b. Support a free maneuver area.
- c. Operate continuously for 22 days.
- d. Support a battalion training cycle.
- e. Operate with 1 range configuration/maintenance day after the 11<sup>th</sup> day permitted.
- f. Support system restart due to loss of power, environmental control, or weather with no data loss.

- g. Support both Ground and Aviation training events.
- h. Support communications between the Control Tower and PUs within the range maneuver space. Repeaters shall be provided as required to relay communications.
- i. Provide an operator workspace designed for comfort and safety based on a continuous 12-hour period of operation.

### **3.2.2.3. System Control (SYSCON)**

The SYSCON WS shall:

- a. Provide the SW and HW necessary to support preparation of exercises.
- b. Include the VSS Application.
- c. Control and manage the DRTS SW.
- d. Distribute, confirm distribution, and log Range Operations SW versions in use at the start of an exercise.
- e. Load schema and table structures used for the database.
- f. Initialize the default configuration database for an exercise.
- g. View and copy configuration data from previous exercises.
- h. Log all operator and automatic actions for subsequent review (i.e. login name and SW accessed).

### **3.2.2.4. Player Administration**

The SYSCON shall:

- a. Create Individual PU configuration data for each exercise.
- b. Control and manage the PU Instrumentation, targets, and players.
- c. Keep the configuration data generated for a PU specific to that PU.
- d. Modify PU operating modes (e.g. sleep, power management, position update rates) by individual or logical groups of PU.
- e. Administratively kill (target down) individual or logical groups of PU.
- f. Administratively reset individual or logical groups of PU.
- g. Administratively reload individual or logical groups of PU.
- h. Administratively resurrect (target up) individual or logical groups of PU.
- i. Transmit any command event to a PU.
- j. Maintain a count of all player events by player.
- k. Report missing events.
- l. Initiate verification data for all PU components.
- m. Log configuration data for all PU components.
- n. Generate player configuration data.
- o. Clear player configuration data.
- p. Load configuration data via the Field Support Equipment (FSE) or transmitted via the RDCS to connected devices.
- q. Generate Ground PU Configuration data.
- r. Generate Aviation PU Configuration data.

### **3.2.2.5. Exercise Administration**

The SYSCON shall:

- a. Provide an application for the control and management of each exercise.
- b. Initialize an exercise.
- c. Reset/re-initialize an exercise.
- d. Recover archived databases.
- e. Initialize the database.
- f. Initialize WSs with the data needed to conduct exercises.
- g. Assign exercise control permissions (e.g. application, data, role (Force), PU control, etc.).
- h. Confirm and establish exercise specific login and WS configurations.
- i. Assign operator access to specific voice channels.
- j. Provide a summary system status from other management applications.
- k. Administratively kill all Instrumented Ranges (IR) controlled players in an exercise.
- l. Administratively reset all IR controlled players in an exercise.
- m. Administratively reload all IR controlled players in an exercise.
- n. Administratively resurrect all IR controlled players in an exercise.
- o. Start exercises.
- p. End exercises.
- q. Archive databases after the corresponding AAR for subsequent reuse.
- r. Archive voice and video after the corresponding AAR for subsequent reuse.
- s. Provide sufficient capacity to maintain archive until 24-hours after the run is set to complete.

#### **3.2.2.6. Player Configuration**

Individual player configuration data shall be created for each exercise. Configuration data generated for a player shall be specific to that player. The player configuration shall include provision for replacement players.

#### **3.2.2.7. Technical Operations and Maintenance Console (TOMC) Function**

The TOMC WS shall provide the SW and HW necessary to support the services and functions described below.

#### **3.2.2.8. System Administration**

The TOMC shall:

- a. Provide tools for the management of all subsystems.
- b. Provide tools for the management of the Local Area Network (LAN)
- c. Provide tools for the management of any external networks that may be attached to the Control Tower.
- d. Use a distributed-management protocol to enable the control of managed devices.
- e. Provide the tools to configure the digital network (LAN).
- f. Provide the tools to maintain the digital network (LAN).
- g. Provide network management using Bilingual Simple Network Management Protocol (SNMP) with user-defined security as specified in the Joint Technical Architecture – Army (JTA-A).

- h. Provide a system diagnostic display capability that provides system status for each component.
- i. Provide a system diagnostic display capability that is operational whenever the system is powered on.
- j. Monitor system level performance.
- k. Monitor subsystem level performance.
- l. Monitor HW component level performance.
- m. Monitor the LAN status.
- n. Report LAN anomalies to the operator.
- o. Detect instrumentation failures.
- p. Detect equipment failures.
- q. Report instrumentation failures.
- r. Report equipment failures.
- s. Monitor the voice communications networks.
- t. Initialize the Tactical Voice and Tactical Data, assign nets, and configure the selection menus for the WSs.
- u. Initialize the Administrative Voice network. Assign nets, set-up recorders, and configure the selection menus for the WSs.
- v. Provide GPS synchronized real time to all WSs.
- w. Provide an interface to a meteorological station.
- x. Provide an interface to administer the station.
- y. Provide the tools and equipment necessary for the archival and restoration of exercise files.
- z. Provide the tools and equipment necessary for the archival and restoration of manage servers.
- aa. Provide the tools and equipment necessary to manage databases.
- bb. Provide the tools and equipment necessary to manage the mounted PU database.
- cc. Provide the tools and equipment necessary to manage the dismounted PU database.
- dd. Provide the tools and equipment necessary to perform a system checkout in preparation for an exercise.
- ee. Provide the tools necessary to create and provide Configuration Management (CM) of all installed SW.
- ff. Provide the tools necessary to create and provide CM of all scenarios.
- gg. Provide the tools necessary to create and provide CM of all scripts.
- hh. Provide the tools necessary to create and provide CM of all configuration data.
  - ii. Provide the capability to monitor the communications data quality.
  - jj. Provide the capability to achieve reliable communication information transfer with at least 95% first time message transmissions.
- kk. Provide the Element Management System (EMS) SW to enable control of the DMTs as described in the PU Specification PRF-PT-745.

### **3.2.2.9. System Diagnostic Status Display Capability (SDSD)**

The SDSD shall:

- a. Perform Built-In Test (BIT) during startup or when requested.
- b. Perform continuous status testing of system components.
- c. Display the updated status.
- d. Provide status information pages.
- e. Maintain a minimum 22-day historical record of diagnostic data.
- f. Perform complete system checks within 10 minutes.

#### **3.2.2.9.1. SDDS Home Page**

The SDDS Home Page shall provide access to status pages for:

- a. Servers Status (SVRS) Page.
- b. SW Status (SWS) Page.
- c. Network Component (NC) Page.
- d. System Interfaces Status (IS) Page.
- e. Alarm Status (ALRMS) Page.
- f. Boot-up Status (BTS) Page.
- g. Stream Status (STRMS) Page.
- h. BIT Page.

#### **3.2.2.9.2. SDDS Home Page Content**

The SDDS Status Page for each system identified above shall:

- a. Provide access to each of the status pages.
- b. Provide one of the following status states for that component:
  - 1) Status State #1: All items are in working order.
  - 2) Status State #2: One or more items are not in working order.

#### **3.2.2.9.3. Status Page Contents**

The Status Pages for each component shall:

- a. Provide the summary status of each component.
- b. Provide the summary status of each sub-component.
- c. Provide access to each of detailed status pages.
- d. Provide a summary status indication for the components and sub-components:
  - 1) Status State #1: All items are in working order.
  - 2) Status State #2: One or more items are not in working order.
- e. Provide access back to the main parent page.
- f. Provide return to last viewed diagnostic page.
- g. Set parameters for Alerts or Alarms.

#### **3.2.2.9.4. Servers (SVRS) Status Page**

The individual SVRS Status Page shall provide:

- a. Server overall HW status.
- b. Server memory status.
- c. Server disk status.
- d. Server operating system status.
- e. Server application SW status.

- f. Server application SW version.
- g. Detailed error report for failed HW.

#### **3.2.2.9.5. Software Status (SWS) Page**

The SWS Page shall provide:

- a. The status of each the system SW application component.
- b. Access to each of the individual SWS SDCS pages.
- c. The SW version of each VSS Computer Software Configuration Item (CSCI).
- d. The detailed error report for any failed CSCI.
- e. The detailed error report for any failed Computer Software Component (CSC).
- f. The detailed error report for any failed Computer Software Unit (CSU).

#### **3.2.2.9.6. Network Components (NC) Status Page**

The NC Status Page shall provide:

- a. Overall HW status.
- b. Memory status.

#### **3.2.2.9.7. System Interfaces Status (SIS) Page**

The SIS Page shall provide information on:

- a. Field Cameras (individual cameras).
- b. Targets System (as a unit not for individual targets).
- c. Ground and Aviation Player Unit Systems (as a unit not for individual PU).
- d. Weather Station.
- e. Video System.
- f. Other main components.
- g. AWSS subsystems.
- h. Battlefield Effects Simulators (BES).
- i. The SIS Status Page shall provide:
  - 1) Overall HW status.
  - 2) Interface status.
  - 3) Memory status (if applicable).
  - 4) Disk status (if applicable).
  - 5) Operating system status (if applicable).
  - 6) Application SW status (if applicable).
  - 7) Other information as applicable to the specific external interfaces.

#### **3.2.2.9.8. Alarms Status Page**

The Alarms Status Page shall:

- a. Monitor the alarms diagnostic display capability.
- b. Provide an updated status when the following occurs:
  - 1) Equipment failure (HW – servers, client, storage device, server, each HW component of System).
  - 2) Interface failure (external systems, Client, and Server).

- 3) SW process failure.
  - 4) Video and Audio Stream recording failure.
  - 5) Video and Audio Stream playback failure.
  - 6) Network failure.
  - 7) Audio and Video storage capacity.
  - 8) Time and date of failure.
- c. Have the capability to review lower level detail information.
  - d. Have the capability to perform the following actions:
    - 1) Acknowledge.
    - 2) Set.
    - 3) Reset/Clear.
    - 4) Inhibit.
  - e. A 22-day minimum historical record of system alarms.

#### **3.2.2.9.9. Boot-up Status Page**

The Boot-up Status Page shall provide a startup check and status report for all of the following:

- a. Servers.
- b. WS.
- c. External interfaces.
- d. AWSS sensors and CSS Server.
- e. Aviation PU Relay Base Stations processor.
- f. PUs.

#### **3.2.2.9.10. Stream Status (STRMS) Page**

The STRMS Page shall:

- a. Display the source name of the stream source.
- b. Provide indication/visual notification for any stream source with a failure.
- c. Display the status of each active stream source.

#### **3.2.2.9.11. Built-In Test (BIT)**

The BIT capability shall:

- a. Enable IPURs to report their ID when entering the network.
- b. Have the ability to be initiated by the IPUR.
- c. Have the ability to be initiated remotely from the SYSCON.
- d. Have the ability to be initiated by the FSE laptop/computers.
- e. Be able to continuously monitor the status of the communications relays and communications links.
- f. Provide the means of determining the functional status of the subsystems down to the Line Replaceable Unit (LRU).
- g. Provide the means of displaying the functional status of the subsystems down to the LRU.
- h. Provide controls and readout reports that they can be easily used and interpreted by the range and maintenance personnel.

- i. Provide SW applications that perform BIT and fault isolation functions that do not cause failure of PU functions.
- j. Provide the ability to monitor switches system performance that are not placed in series paths for purposes of introducing stimuli, diverting normal signals.
- k. Identify power supply faults to the failed power supply.
- l. As a minimum, 75% of all Circuit Card Assembly (CCA) faults shall be isolated to no more than 1 CCA.
- m. As a minimum, 90 % of all CCA faults to no more than 2 CCA.
- n. As a minimum, 100% of all CCA faults to not more than 3 CCA.
- o. Upon indication of failures of COTS equipment, diagnostic routines, procedures, test units, and other means from the vendor shall be used to isolate the faulty HW to the LRU.
- p. Results feedback for BIT initiated from the FSE and Control Tower shall be limited to what the PU provides for BIT and status reports

### **3.2.2.10. Mapping Administration**

A mapping administration function shall:

- a. Provide the capability to maintain terrain databases for the generation and printing of maps, Situational Awareness Window (SAW) 2D, and AARs.
- b. Combine map files (e.g. elevation, features, and lines of communication).
- c. Scale, scanned or digital products such as photos, drawings, plot plans, and photographic views.
- d. Register scanned or digital products such as photos, drawings, plot plans, and photographic views.
- e. Overlay scanned or digital products such as photos, drawings, plot plans, and photographic views.
- f. Provide edit capability for terrain databases.
- g. Allow overlay of terrain elevation data with digitized data from imagery sources.
- h. Provide a graphics overlay editor capable of ground and aviation graphics such as air corridors and waypoints.

### **3.2.2.11. Database Administration**

Database Administration shall include:

- a. A CTIA compliant database with management and development tools.
- b. All tables necessary to support specific Range Operations.
- c. All tables necessary to support scoring.
- d. All tables necessary to support aviation SW functions.
- e. WS configurations.
- f. Instrumentation configurations.
- g. Weather parameters.
- h. Message sets.
- i. Scenarios.
- j. Audio and video metadata.

- k. Ability to link data elements and store as unique types (e.g. unique units, unique references).
- l. Automated conversion routines for known data formats.
- m. Ability to support manual conversion of data.
- n. User selectable data format (coordinates or datum).
- o. Supporting multiple concurrent exercises (a firing table qualification run).
- p. Segregating the data in such a manner that each exercise can operate independently.
- q. Maintaining the integrity of any database Logs.
- r. The ability to link player lists, player type, weapon type, and descriptions.
- s. Creating linkages between weapon types, ammunition types, and vulnerability data.
- t. Maintaining data synchronization among all the elements (i.e., scenario, forces, PU data, video, audio) of a scenario run, so all related data from planning, execution and AAR are accessible through a single scenario instance identifier (name).

### **3.2.3. Exercise Management**

#### **3.2.3.1. Crew Evaluator Workstations (CEWs)**

The CEWs shall:

- a. Control the exercise.
- b. Control the AAR.
- c. Monitor the exercise.
- d. Monitor the AAR.
- e. Control execution of training exercises.
- f. Provide a control interface to the Voice Communications Interface (VCI).
- g. Provide the HW required for monitoring the radio networks.
- h. Provide command screens for interacting with the PU in an exercise.
- i. Provide a SAW that display symbology overlaid on the SAW map or area graphic.
- j. Provide a SAW that display tactical graphics overlaid on the SAW map or area graphic.
- k. Provide an ability to enter administrative commands to kill individual players in an exercise.
- l. Provide an ability to enter administrative commands to reset individual players in an exercise.
- m. Provide an ability to enter administrative commands to reload individual players in an exercise.
- n. Provide an ability to enter administrative commands to resurrect individual players in an exercise.
- o. Provide near real time event status of events on a tactical map display by icon color changes.
- p. Enable scrolling text display of all types of events in a window.
- q. Enable scrolling to be controlled with a "scroll mouse" or by slider.

- r. Enable scrolling to display any event occurring within the previous 5 minutes.
- s. Provide a graphical display of ground PU (i.e. location and state) events in the exercise area.
- t. Allow an operator to select a minimum of 12 video feeds such as the Thru-Site-Video (TSV) from ground vehicles, range cameras, and UAS video via a Common Ground Station (CGS).
- u. Monitor multiple concurrent exercises.
- v. Segregate displays of exercise data.
- w. Provide CEWs, which support the SAW, VSS, and Evaluation Display Console functionality.
- x. Provide the SW and HW necessary to support run execution operations.
- y. Provide the SW and HW necessary to support replay.
- z. Provide the SW and HW necessary to support AAR preparation.

### **3.2.3.2. Situational Awareness Window (SAW)**

The SAW requirements are applicable to any exercise and system control display system. The SAW shall provide:

- a. Accurately overlaid through a common coordinate system on 2D maps or representations of the terrain (i.e., PU, entities, devices, tactical overlays, air corridors, range fans, fields of view, and other graphics).
- b. Accurately and sequence overlay graphics that are scanned drawings (e.g. tactical overlays), dynamically drawn (e.g. air corridor), computed (e.g. range fans), symbols (e.g. unit symbology), map product files (e.g. terrain databases), photographs (e.g. aerial photographs), video (e.g. UAS video), or vector graphics.
- c. The capability to support multiple SAW in either tiled or cascaded view.
- d. Provide a graphical display of Aviation events, when appropriate, (i.e. location and status) in the exercise and installation area covered by the Aviation PU radio range.
- e. At a minimum, the exercise area and installation areas shall include the Forward Area Refueling Point (FARP) and shall be displayed in the SAW when applicable.

### **3.2.3.3. SAW Exercise Awareness**

The SAW Exercise Awareness function shall:

- a. Depict player events with-in 1 second.
- b. Reflect player status changes based in the setting of the PU.
- c. Reflect player position within 1 second after its report is received at the corresponding system server.
- d. Display pairing information.
- e. Display platform heading.
- f. Support triggered dynamic plots of Line Alerts.
- g. Support triggered dynamic plots of Area Alerts.
- h. Support display of weapon fans for all 1553 platforms.

- i. The weapon fan shall be selectively displayed as an outline, a fill color, or a pattern.
- j. Display scalable symbols.
- k. Enable scaling by operator action or by rules.
- l. Allow selection of symbols for scaling to permit the use of a pointer right-click.
- m. Allow selection of symbols for scaling to permit the use of a magnifier tool.
- n. Allow selection of symbols for scaling to permit the capability to manually select from menu.
- o. Allow scaling to be by percentage of default size.
- p. Allow scaling by rules to include magnify on fly-over pointer.
- q. Allow scaling by rules to include magnify with map scale.
- r. Allow scaling by rules to include magnify with map scale but within a stated range.
- s. Support player orientation symbology.
- t. Support weapon orientation symbology.
- u. Support display of a group as a single icon.
- v. Support displaying a player by entering the player ID.
- w. Support displaying a player by selecting the player ID.
- x. Ensure the map display can pan to display the player in the current window.
- y. Display only members in a group that are assigned to an active run.
- z. Support annotation of symbology display of only player ID.
- aa. Allow different options for annotation of symbology.
- bb. Allow annotating with player ID's upon operator action.
- cc. Support annotation of symbology with bumper numbers.
- dd. Provide history trails on operator request.
- ee. Allow history trails to be selected based on start time.
  - ff. Allow history trails to be selected based on end time.
  - gg. Allow history trails to be selected based on duration of the track.
  - hh. Allow History trails to be selectable by individual player.
    - ii. Allow History trails to be selectable by group.
    - jj. Allow History trails to be selectable by all players.
- kk. Toggle or displace overlapping symbols with position lines to preclude loss of information presentation to the operator.
  - ll. Reflect status changes through readily identifiable changes to the player symbology.
- mm. Display non-persistent effects with sufficient duration to allow an operator to react to their presence.
- nn. Allow selectable icons and symbology on map displays through "mouse click to change the focus for subsequent status displays and command actions.
- oo. Allow selectable icons and symbology on map displays through keyboard action (e.g., tabbing through all icons) to change the focus for subsequent status displays and command actions.
- pp. Provide a zoom and scaling feature.
- qq. Allow map scaling (zoom) within the display.

- rr. Allow zooming to be continuous for vector graphics.
- ss. Allow zooming to be done as a step function for raster graphics.
- tt. Allow zooming to be provided in fixed multipliers of existing scale.
- uu. Enable scaling to be provided relative to standard map scale representations (1:1000, 1:25,000).
- vv. Display the current scale constantly on the map window.
- ww. Provide a capability to adjust the portion of the map displayed.
- xx. Provide a capability to spawn a second SAW from an active window.
- yy. Ensure that when spawning a second SAW display (for monitor mode) that the initial spawned window is created from within an existing SAW.
- zz. Ensure that when spawning a second SAW display (for monitor mode) that it will inherit all settings from the controlling SAW.
- aaa. Ensure any settings are modifiable at or after the new SAW creation.
- bbb. Ensure each SAW retains its own properties (e.g. scale, overlays, filters, etc.).
- ccc. Enable the operator to toggle through the windows to quickly progress to different areas of interest.
- ddd. Provide map-centering functions through operator-entered coordinates or "mouse" action.
- eee. Allow scrolling of the map through "mouse" action ("click and drag").
  - fff. Enable dragging the pointer to any window edge to continue the scrolling in the same direction as the edge chosen.
- ggg. Support use of coloring to display difference in terrain elevation.
- hhh. Define and reflect exclusion zones.
  - iii. Ensure exclusion zones be polygons whose vertices are defined.
  - jjj. Ensure exclusion zones shall include altitude and firing points for aircraft engagements.
- kkk. Define and reflect demarcation lines.
  - lll. Ensure demarcation lines (Line Alerts and Area Alerts) consist of lines between 2 or more points.
- mmm. Provide the capability to save or retrieve exclusion zones between exercise iterations.
- nnn. Provide the capability to save or retrieve demarcation lines between exercise iterations.
- ooo. Provide a method for drawing exclusion zones with the pointer or by keyboard entry.
- ppp. Provide a method for drawing demarcation lines with the pointer or by keyboard entry.
- qqq. Provide the capability for demarcation line crossing to generate alerts to operators.
- rrr. Provide the capability for exclusion zone line crossing to generate alerts to operators.
- sss. Provide the capability of predefining a step target, PU, or scoring system action and automatically executing a command (e.g. initialize scoring on a target, change PU reporting rates, etc.) as a result of the action.

#### **3.2.3.4. SAW Exercise Evaluation**

The SAW Exercise Evaluation function shall:

- a. Provide a capability to display a terrain profile between any 2 points in a separate window within 20 seconds.
- b. Provide calculation of distance between any 2 selected points.
- c. Provide calculation of azimuth between any 2 selected points.
- d. Ensure the azimuth is referenced to the first point selected.
- e. Ensure the back-azimuth is referenced to the second point selected.
- f. Display the elevation of any selected point on the map.
- g. Support the Military Grid References System (MGRS) as the default.
- h. Support Universal Transverse Mercator (UTM).
- i. Support Latitude/Longitude.
- j. Support local coordinate systems.
- k. Ensure the coordinate system displayed shall be dynamically selectable.
- l. Display on mouse-click the coordinates of any location in the current coordinate system.
- m. Ensure the datum used in converting coordinates use the World Geodetic System (WGS)-84.

#### **3.2.3.5. SAW Symbology**

The SAW Symbology function shall:

- a. Use symbology or icons to display individual players, objects, and military units.
- b. Provide an application tool to generate and maintain a symbol library.
- c. Provide an application tool to attach descriptors to a symbol
- d. Provide an application tool to provide symbols to other applications.
- e. Provide the initial library consisting of MIL-STD-2525 symbology and its descriptors.
- f. Ensure the symbol tool supports the generation of symbols as described in the standard.
- g. Ensure each symbol has an anchor to indicate the unit's position.
- h. Ensure each symbol has an anchor to indicate the unit's orientation.
- i. Provide Military Symbology that can be composed of several individual symbols representing the Unit.
- j. Provide Military Symbology that can be composed of several individual symbols representing the mission.
- k. Provide Military Symbology that can be composed of several individual symbols representing the text annotation for the Unit descriptors.
- l. Use the player name or descriptor from the SAW and then compose and return the appropriate symbol.
- m. Not obscure the graphics on which it is overlaid.
- n. Utilize display management techniques to de-clutter the screen presentation.
- o. Provide symbols in a standard size which are scalable by the SAW, or filtering.

- p. Ensure overlapping symbols can be toggled or displaced with position lines.
- q. Maintain the symbols and their corresponding descriptors in the database.

### 3.2.3.6. Exercise Control (EXCON)

The table names shall be displayed as a drop down list. Selection of a specific table name shall permit the entry and selection of the following:

- a. Symbology derived from the unit name.
- b. Instrumentation.
- c. Call signs.
- d. Assigned video channels (i.e. TSV, aircraft data recorders, and crew).
- e. Assigned voice channels.
- f. Military Symbology.
- g. Crew.
- h. Weapon platform, weapons, ammunition loads, etc.

### 3.2.3.7. Exercise Control Function

The Exercise Control function shall:

- a. Provide the scenario and the target control GUI.
- b. Provide the ability to Start an active step.
- c. Provide the ability to Stop an active step.
- d. Provide the ability to Pause an active step, which will conceal targets.
- e. Provide the ability to Resume Run.
- f. Allow all the scenarios to be suspended or stopped.
- g. Reset (Conceal) targets immediately upon Pause or Stop commands, which are set by the operator.
- h. Allow a designated operator to initiate the Start functions.
- i. Allow a designated operator to initiate the Resume functions.
- j. Allow Resume to be executed from any step or sequence in the scenario.
- k. Support transfer of "click position" information to other input screens.
- l. Ensure click position information is translated to the coordinate system selected by the operator or required by the receiving application.
- m. Allow a current view to be saved and viewed as a named file.
- n. Ensure SAW files are saved in such a manner that when retrieved each file retains all its' capabilities.
- o. Ensure SAW files are saved in such a manner that when retrieved the operator can replay from that point.
- p. Support multi-colored maps and displays.
- q. Support use of false coloring to display difference in terrain elevation.
- r. Reflect exclusion zones.
- s. Reflect exclusion alerts.
- t. Reflect demarcation lines.
- u. Ensure the operator is able to activate an alert and the predefined command as a result of the alert.
- v. Ensure the operator is able to deactivate an alert and the predefined command as a result of the alert.

- w. Ensure the operator is able to redefine the command executed as a result of the alert.
- x. Provide the capability for local operator annotations.
- y. Provide the capability for global annotations.
- z. Be configured to operate with the WSS WS as a "pair" of WSs.
- aa. Provide the completed Execution run information to the VSS to load.
- bb. Provide a series of commands to the VSS relative to display of playlist video streams.

### **3.2.3.8. Replay Functions**

The Exercise Management Replay Function shall:

- a. Use filters to control the display of data.
- b. Use filters to control the interaction with data.
- c. Enable replay functions without limiting current exercise activities.
- d. Replay archived data resident on the server.
- e. Support subordinate filter selection to operator privileges.
- f. Support permit modification only within the limit of operator privileges.
- g. Support local filters.
- h. Support global filters.
- i. Allow as an option display of instrumentation status during replay.
- j. Enabled replay capability by login privilege.
- k. Ensure that access limits to current exercise activities, archived data, specific PU groups, timeframe, or exercise location are controlled by login privilege.
- l. Support playback of events and time-synchronized evaluator WS information, audio and video data for review, analysis, and comment insertion.
- m. Support replay of WS screen captures.
- n. Support replay of EDC screen captures.
- o. Support replay of archived data for WS Components.
- p. Support replay of archived data for EDC Components
- q. Support replay of archived data for individual EDC Components.

### **3.2.4. Video System Suite (VSS)**

The VSS shall meet the requirements in the VSS Specification PRF-PT-769. The VSS shall meet the requirements in this document (i.e. Cybersecurity, Safety, Electronic and System Protection, Environmental, Logistics, etc.).

### **3.2.5. Ingest Workstation (WS)**

The system shall provide a standalone Ingest WS with the HW and SW to integrate video and data from the IPUR into the Control Tower. The Ingest WS system shall:

- a. Synchronize all IPUR data with other run data.
- b. Provide the capability to tag this data and utilize it for playback, generation of bookmarks, and AAR Presentation.

- c. Provide the necessary equipment to download data.

### **3.2.6. Hand-Held Target Control Function**

DRTS system shall provide the capability to perform target control functions from down range using a hand-held device. The hand-held control function shall:

- a. Provide a wireless connection to the IR network.
- b. Use the same target controller as used by other IR tools.
- c. Provide a SAW display of the downrange assets.
- d. Have the same functionality on downrange assets as the SYSCON tools.
- e. Provide the following target control commands:
  - 1) Expose.
  - 2) Conceal.
  - 3) Set hit sensitivity.
  - 4) Set hits to kill.
  - 5) Set response on hit (Bob Hold).
  - 6) Set response on kill (Bob Kill).
  - 7) Set Moving Armor Target (MAT)/Moving Infantry Target (MIT) direction forward and reverse.
  - 8) Set MAT/MIT Speed.
  - 9) Send MAT/MIT to end of track.
  - 10) Send MAT/MIT home.
- f. Display all target events in the hand-held as well as all other IR tools.
- g. Display all target status in the hand-held as well as all other IR tools.

### **3.2.7. Scenario Development Tool (SDT)**

The SDT capability shall:

- a. Create scenario steps.
- b. Edit scenario steps.
- c. Ensure each scenario contains a set of steps with various automated target behaviors configured for one or more targets.
- d. Provide doctrine based task data to support the creation of scenarios.
- e. Enable scenarios to be modified to meet the Commander's Intent.
- f. Generate the scenarios scripts in a format usable by the SYSCON and EXCON functions for execution.
- g. Create scenarios using menu-based tools.
- h. Enable actions to be executed based on a specified time, trigger event, or on command.
- i. Permit the grouping of instrumentation commands to represent phases (e.g. threat attack, threat withdrawal) or tasks in an exercise (e.g. movement to contact, attack, raid, ambush, etc.).
- j. Control an exercise.
- k. Sequence an exercise.
- l. Issue Targetry commands.
- m. Issue instrumentation commands.
- n. Support conditional execution.

- o. Ensure the condition is based on data contained within the database uploaded.
- p. Permit the generation of scenarios based on unit executing the tasks and corresponding ARMY doctrine.
- q. Permit the generation of Commanders Intent scenarios based on unit executing the tasks.
- r. Permit the generation of scenarios based on unit Commander Intent executing the tasks.
- s. Create free form tasks or modify an existing doctrine task to provide Commander Intent.
- t. Provide a means to create AAR templates.
- u. Provide a means to store AAR templates.
- v. Identify alternate targets if the primary target fails.
- w. Permit the assignment of targets or target arrays into groups or zones relative to a firing position.
- x. Allow the groups or zones to be configurable by providing a user interface to define a group or zone name and associated range, area, or target list.
- y. Define attrition of targets due to successful target hits (depleting target array).
- z. Allow attrition groups to include the targets presented and the condition for lowering all targets within the group (e.g. 30% hit, 3 of 5 killed, total hits sustained within group, etc.).
- aa. Simulate scenario execution that displays synchronized data for target and BES events.
- bb. Support the current and previous version of gunnery doctrine for Abrams, Bradley, Stryker, and helicopter platforms.

### **3.2.8. Range Data Editor (RDE)**

The RDE Function shall provide the capability to manage, edit, and view:

- a. Ability to import from an external data file.
- b. Generate Range data file.
- c. Ability to edit the Range data file.
- d. Training Installation.
- e. Training Event Types.
- f. Supported Target Types.
- g. Infantry Target Clusters.
- h. Target Silhouettes.
- i. Supported Target Protocol Types.
- j. Target Emplacements.
- k. Moving Target Track Location.
- l. Target Lift Devices.
- m. BES.
- n. Radio Towers.
- o. Cameras.
- p. Camera Presets.

- q. Limit Markers.
- r. Ground PUs.
- s. Supported Weapons.
- t. Firing Lanes.
- u. Trenches.
- v. Display Buildings.
- w. Deployable Targets Range Support Flag.
- x. Firing Lines.
- y. Ground Firing Positions.
- z. Safe and Seen List.
- aa. Manage Facility Images.
- bb. Building Floor Layout Images.
- cc. Aircraft PUs.
- dd. Ground PUs
- ee. Aircraft Firing Positions.

### **3.3. AAR Facility**

#### **3.3.1. AAR Presentation Workstation (PWS) Podium**

The PWS Podium shall:

- a. Have the SW and HW necessary to present AARs at each range AAR Theater.
- b. Enable all VSS functions.
- c. Contain a read and write DVD capability.
- d. House all PWS equipment with appropriate ventilation to support an AAR in a single theater.
- e. Include a VSS WS.
- f. Include a HD Display Monitor.
- g. Provide slide out Keyboard Shelf.
- h. Provide a hideaway monitor capability (used to hide monitor when not in use).
- i. Provide an external Laptop connection using RGB and HDMI connectors.
- j. Display the laptop screen to 1 theater or 2 theater projectors from either of the PWSs.
- k. Provide manual switch to control the projector video and audio inputs (connect PWS to projectors, speakers and laptops).
- l. Provide SW controllable switch to control the projector video and audio inputs (connect PWS to projectors, speakers and laptops).
- m. Provide amplifier control for theater speaker volume.  
Provide hardwired microphone for presenter.
- o. Provide a wireless lapel microphone for presenter with a minimum range of 200 feet.

#### **3.3.2. Theater Audiovisual Equipment**

The Theater Audiovisual Equipment shall:

- a. Have a projector or display for each theater.
- b. Have a minimum projector performance of the following:
  - 1) Resolution 1920 x 1080.
  - 2) Brightness 4000 Lumens.
  - 3) Ethernet connection (CAT6 / RJ45) for control.
  - 4) HDMI connection for video.
  - 5) 120VAC.
  - 6) Remote Control.
- c. Have ceiling speakers for each theater.
- d. Have ceiling mounted microphones for each theater.
- e. Have one screen, per projector, with an aspect ratio of 16:9.

### **3.4. Field Support Equipment (FSE)**

The FSE suite shall:

- a. Communicate directly with a IPUR.
- b. Provide the capability to reset the IPUR (Admin Only).
- c. Provide technicians the capability to troubleshoot IR field instrumentation.
- d. Provide the capability to download SW to applicable device firmware and other applicable media.
- e. Provide the capability to download configuration data to applicable device firmware and other applicable media.
- f. Provide the capability to download configuration data to field instrumentation.
- g. Provide the capability to verify configuration data to field instrumentation.
- h. Be capable of configuring at least 10 IPURs per hour, to include time required for HW connections and SW setup.
- i. Be capable of downloading event data from 10 IPURs per hour, to include time required for HW connections and SW setup.
- j. Provide the capability to download configuration data from the Control Tower.
- k. Provide the capability to upload event data from IPURs to the Control Tower.
- l. Provide the capability to execute all commands to the IPUR identified in the corresponding ICD.
- m. Provide the capability to enter administrative notes by observer/controller personnel and maintenance technicians using a text editor or word processor compatible with the EXCON word processor.
- n. Be one-person portable.
- o. Provide a GPS to determine the position of the installed field instrumentation
- p. Provide a GPS to relay or transfer the position of the installed field instrumentation to the Control Tower.
- q. Consist of upload/download devices (e.g., laptop computers), voice transceivers, maintenance aids, GPS, and other equipment needed to prepare the IPUR for use.

- r. In conjunction with an IPUR Transceiver, be capable of communicating directly with other IPUR through the RDCS network as well as serve as a system control function.
- s. Troubleshoot IPUR vehicle instrumentation.
- t. Allow the user to update the configuration data to the IPUR.
- u. Set configuration data IPUR vehicle instrumentation.
- v. Download new SW and firmware on IPUR.
- w. Weigh 7 pounds or less.

### **3.5. Target System**

DRTS targets shall comply with the FASIT Performance Specification (PRF-PT-00468), FASIT System Devices Interface Control Document (ICD.FASIT.SYS), FASIT Audio Devices Interface Control Document (ICD.FASIT.AUDIO), FASIT Engagement Scoring Devices Interface Control Document (ICD.FASIT.ESD), FASIT Presentation Devices Interface Control Document (ICD.FASIT.PD), FASIT Pyrotechnic Device Interface Control Document (ICD.FASIT.PYRO), FASIT Range Interface Module Interface Control Document (ICD.FASIT.RIM), and FASIT Representation Devices Interface Control Document (ICD.FASIT.RP).

#### **3.5.1. Targetry System (TS) General**

All targetry systems shall:

- a. Depict the different threat presentations, as required.
- b. Replicate individual vehicles (combat and non-combat).
- c. Replicate various unit formations (multiple targets controlled with a common behavioral script).
- d. Sense/score hits.
- e. Relay the Sense/score hits to the Control Tower.
- f. Provide two-dimensional presentations of frontal, flank, and oblique vehicles.
- g. Provide realistic three-dimensional (3-D) presentations of frontal, flank, and oblique vehicles.
- h. Accommodate vehicle IAW TC 25-8.
- i. Accommodate personnel IAW TC 25-8.
- j. Accommodate aerial targets IAW TC 25-8.
- k. Portray vehicle thermal signatures for offensive postures.
- l. Portray vehicle thermal signatures for defensive postures.
- m. Provide data/signatures that are consistent with information from the National Ground Intelligence Center (NGIC), Technologies Directorate, Signatures, & Countermeasures Division.
- n. Provide thermal types of three-dimensional, mannequin type infantry personnel targets, including standing E type silhouettes.
- o. Provide non-thermal types of three-dimensional, mannequin type infantry personnel targets, including standing E type silhouettes.
- p. Provide friendly target systems that portray vehicle thermal signatures for offensive postures.

- q. Provide friendly target systems that portray vehicle thermal signatures for defensive postures.
- r. Provide data/signatures consistent with Night Vision Laboratory information.
- s. Require no special tools.
- t. Ensure wiring harnesses are routed to minimize direct fire, ricochet, or debris damage.
- u. Fit into existing target pits as specified in the Army Corps of Engineers Design Manual CEHNDM 1110-1.
- v. Be a 2-person lift for any module of a single target system. This does not apply to MATs or 3-D EDOT aviation targets.
- w. Be water resistant.
- x. Be non-flammable.

### **3.5.2. Target Types**

The targets shall represent the following types:

- a. Stationary Armor Target (SAT) (Able to lift frontal and Flank target silhouettes)
- b. Moving Armor Target (MAT)
- c. Stationary Infantry Target (SIT)
- d. Moving Infantry Target (MIT)

### **3.5.3. Battlefield Effects Simulators (BES)**

The IR shall interface to the BES devices IAW the BES Target ICD (DMPRC-HOOD-BES-TARGET-ICD). The DRTS system shall utilize:

- a. Mines (black or white smoke).
- b. Conventional indirect fire (black or white smoke).
- c. Small arms fire (audio cue devices).
- d. Target Hit and Fire indicators (black or white smoke).
- e. Biological and Chemical contamination (yellow smoke).
- f. Small Arms Fire BES to indicate muzzle flash and round detonation.

### **3.6. AWSS**

The Aerial Weapon Scoring System (AWSS) is the fielded solution to provide objective scoring for Army air-to-ground live fire qualification IAW TC 3-04.3.

### **3.7. Field Cameras**

#### **3.7.1.1. General**

The field camera shall:

- a. Be installed and integrated into the DRTS system.
- b. Incorporate day/color capabilities.
- c. Incorporate thermal capabilities.
- d. Provide auto focus capability on thermal camera.
- e. Provide auto focus capability on color/day camera.

- f. Meet International Electro-technical Commission (IEC) 529 IP-65 rating for degrees of protection provided by enclosure (IEC 60529).
- g. Provide NTSC or PAL standard Video or H.264 output.
- h. Provide a minimum of 15 frames-per-second.
- i. Have a total weight for the thermal camera, color camera, and pan/tilt unit not to exceed 77 lbs.
- j. Ensure that the thermal camera supports a spectral band or wavelength of 3-5 $\mu$ m.
- k. Ensure that the day/color camera Field of View (FOV) is a continuous optical FOV.
- l. Ensure that the day/color camera FOV range is a minimum of 40° wide to 2° narrow horizontal.
- m. Ensure the thermal camera FOV is a continuous optical FOV.
- n. Ensure the thermal camera FOV range is a minimum of 5° wide to 1.1° narrow horizontal.
- o. Have a digital zoom of at least 2x for day cameras.
- p. Have a digital zoom of at least 2x for thermal cameras.
- q. Be capable of providing 1920 x 1080 High Definition daylight video.
- r. Be capable of proving 640 x 480 thermal images.
- s. Have a power consumption of 140 watts or less.
- t. Be environmentally sealed without requiring additional housings to protect against the environment.
- u. Command and control electrical interface shall support RS232, RS485, or TCP/IP protocols.
- v. Provide an optical zoom capability from minimum to maximum field of view range.

### 3.7.1.2. Control

The field camera pan/tilt unit shall:

- a. Be built into the camera system.
- b. Provide 360° continuous movement
- c. Have a 0.05° accuracy level.
- d. Utilize the RS232, RS485, or TCP/IP protocols to interface with command and control.
- e. Utilize the Tactical Automated Security Systems (TASS) Pelco-D or P protocol to interface with command and control.
- f. Be capable of supporting SW presets that incorporate azimuth, elevation, zoom level, and focus settings for each type of camera.
- g. Have a preset recall accuracy of .01°.

### 3.8. Range Digital Communications System (RDCS)

The RDCS is the main communication system of the entire range infrastructure. The RDCS has the following subcomponents: The Range Control System (RCS) is the wireless infrastructure utilized to communicate with the IPURs. The DMTs, AWSS, UAS communication infrastructure. All of these subcomponents plug into the RDCS fiber to communicate with the Control Tower (CT).

The RDCS shall:

- a. Comply with frequency allocations and spectrum use available at the intended installation.
- b. Have a bidirectional communications link between the Control Tower and the range assets.
- c. Have position location and events from the instrumented participants (i.e. combat vehicles, and DMTs).
- d. Have the ability to send command/control messages generated at the Control Tower to the instrumented participants.
- e. Have the ability to receive command/control status messages generated from the instrumented participants to the Control Tower. Have a two-way data link between the PU and the SYSCON.
- f. Report instrumented player position including when in the prone position, for the dismounted Soldiers.
- g. Report instrumented player events including when in the prone position, for the dismounted Soldiers.
- h. Have voice communication links for the participants.
- i. Serve as the Emergency response network.
- j. Be the link for transferring video collected by the PUs to the Control Tower.
- k. Have wired and wireless links as required based on the specific range configuration.
- l. Have voice communications through SINCGARS.
- m. Have the capability for the PUs to be used on DRTS ranges.
- n. Enable PU communication infrastructure to provide the capability to support existing PUs that use the latest 802.11 network protocols.

#### **3.8.1.1. RDCS Architecture**

The RDCS architecture shall:

- a. Be designed to maximize the use of standard parts, subassemblies, and COTS HW to minimize development.
- b. Use the same network for data, video and voice communication.
- c. Not require the installation of video telemetry components for its operation.
- d. Provide for bidirectional communications between a PU and the access points to the fiber-optic infrastructure.

#### **3.8.1.2. RDCS Network**

The RDCS shall:

- a. Provide a Network Controller function at the Control Tower.
- b. Provide Transceiver & Control Units (TCU) interfaced to the PUs for digital data communications.
- c. Provide a Voice and Data communication link to the control tower/Vehicle Crew Evaluator (VCE).
- d. Provide a push to talk function for voice communication.

### **3.8.1.3. RDCS Network Controller**

The RDCS Network controller shall:

- a. Interface with the Control Tower using a LAN for network setup, management, and control from the TOMC.
- b. Use TCP/IP protocol.
- c. Permit remote updating of instrumented player configuration over-the-air.
- d. Permit remote updating of instrumented player configuration as serial interface downloads.

### **3.8.1.4. RDCS Network Administration**

The RDCS Network control and management functions shall be performed by the TOMC. The RDCS Network Administration shall:

- a. Select the transmission channels of the digital communications network.
- b. Monitor the Radio Frequency (RF) network status.
- c. Report anomalies to the operator.
- d. Initiate end-to-end BIT for the PU by individual or group of PUs.
- e. Request, report, and log the SW versions for all managed RF network devices.
- f. Provide an interface between the RF data network and the local area network commensurate with the security levels of both networks.
- g. Control the flow of data between components of the Control Tower and the RF network.
- h. Provide GPS Time to the CSS.
- i. Reset or restart components.
- j. Interface with the range servers using a LAN for network setup, management, and control from the TOMC.
- k. Use TCP/IP protocol IAW JTA-A.
- l. Permit remote updating of instrumented player configuration over-the-air as well as serial interface download.

### **3.8.1.5. RDCS PU Administration**

The RDCS application shall:

- a. Provide an application for the administration, control, and management of the PU Instrumentation components(IPUR/DMTs).
  - 1) Reset.
  - 2) Position Update Rates.
  - 3) Reporting Rate.
- b. Initiate verification and log configuration data for all PU components.
- c. Generate player configuration data.
- d. Clear player configuration data.
- e. Control the associated PU.
- f. Load configuration data to PUs via the FSE or transmitted via the RDCS to connected devices.
- g. Transmit and receive any valid PU message.
- h. Generate PU Configuration data.

- i. Permit remote updating of instrumented player configuration over-the-air as well as serial interface downloads.

#### **3.8.1.6. Global Positioning System (GPS) Reference Receiver**

The RDCS shall provide a GPS reference receiver. The RDCS GPS reference receiver shall:

- a. Provide data interface to the Control Tower with operator interface and display status SW.
- b. Allow for complete control and monitoring of the reference receiver from the TOMC.
- c. Be installed at the Control Tower.

#### **3.8.1.7. RDCS Time base**

A common time base shall be established for all instrumented players, AWSS scoring systems, field cameras, and the Control Tower. The DRTS System time shall be synchronized through the GPS time standard. Each PU receiver shall output GPS time accurate to within one millisecond.

Each event and change in position shall provide a time tag to allow reconstruction of position location and engagement events. The time tag accuracy shall be within 10 milliseconds. In case of GPS signal loss, an alternate method of time tagging shall be provided until the lost GPS signal is reacquired.

#### **3.8.1.8. RDCS Coverage Area**

The RDCS shall provide coverage that includes all range training areas, course roads, maneuver areas, installation pad, Air/Ground Integration (AGI) village and periphery around the AGI village, Live Fire Villages and Urban Clusters.

#### **3.8.1.9. Range Digital Communications System (RDCS) Capacity**

The RDCS shall have sufficient throughput capacity to accommodate up to 172 combined air and ground participants. Range Targets are considered range participants.

#### **3.8.1.10. Transmission Rate**

RDCS shall support concurrent transmission under the maximum transmission rates for the following data types:

- a. Digital position updates for all MITS, MATS, ground Vehicle, DMTs, Helicopter, and UASs.
- b. Digital telemetry for ground vehicles, helicopters and UASs.
- c. Video and audio for ground vehicles, helicopters and UASs.
- d. Voice communication for up to 100 users
- e. Support AWSS data transmission for up to 10 targets.

### **3.8.1.11. Transmission/Reception**

The RDCS shall be capable of point-to-point unicast, multicast, and broadcast communications.

### **3.8.1.12. Update and Reporting Rates**

#### **3.8.1.13. Update Rates**

Update rates shall be periodic dependent on the type PU category. The RDCS shall provide sufficient bandwidth and capability to provide the following rates for position location:

- a. Ground vehicle - 1 sample/second.
- b. Dismounted troops - 1 sample/5 seconds.
- c. Aircraft – 1 samples/second.

#### **3.8.1.14. Reporting rates**

Position location reporting rates to the Control Tower shall:

- a. Be controllable within the exercise scenario by the SYSCON or the TOMC.
- b. Provide elapsed time reporting rates controllable within the following ranges:
  - 1) Ground vehicle/air defense - 1 to 60 seconds.
  - 2) Dismounted troops - 5 seconds to 3 minutes.
  - 3) Aircraft – 1 to 60 seconds.
- c. Provide distance traveled reporting rates controllable within the following ranges:
  - 1) Ground vehicles - 1 m to 10 km.
  - 2) Dismounted troops - 10 m to 10 km.

#### **3.8.1.15. Voice & Data Communications Interface (VDCI)**

The VDCI shall:

- a. Monitor communications traffic for incorporation by the AAR SW.
- b. Collect communications traffic for incorporation by the AAR SW.
- c. Time tag communications traffic for incorporation by the AAR SW.
- d. Store communications traffic for incorporation by the AAR SW.
- e. Route incoming and outgoing communications between the field units and Range Operations WS.
- f. Interface SINCGARS with voice.
- g. Interface to operations and maintenance voice networks.
- h. Provide a common voice intercom system between all range operations WSs.
- i. Record all voice communications with the crew on active exercise (excluding the range operations intercom and telephone services).
- j. Time tag all recorded voice communications during runs execution.
- k. Play back voice communications in time synchronization with exercise events.
- l. Provide the WS operator the capability to review audio events,

- m. Provide the WS operator the capability to play back the associated audio clips.
- n. Provide simultaneous recording and playback of voice communications.
- o. Provide each radio in the Control Tower with an Uninterruptible Power Supply (UPS) if Control Tower power is not supported with a UPS.
- p. Utilize a lapel whisper microphones with vocoders.

#### **3.8.1.16. Video Telemetry**

The RDCS shall provide the necessary equipment to support a digital video telemetry link. This digital video telemetry link shall be designed for efficient use of communications channels. This digital video telemetry link shall maintain the original source resolution.

#### **3.8.1.17. Priority Assignment**

The RDCS shall provide the capability to assign priorities to certain channels, networks or users.

#### **3.8.1.18. Talk Groups or Sub-Nets**

The RDCS shall support a minimum of 200 user selectable sub-nets. Voice communications shall have the following operational characteristics:

- a. Queuing Time: a maximum wait time of 5 seconds.
- b. Link Capabilities: user selectable unicast, multicast and broadcast capabilities.
- c. Conference Calls: support multi-user conference calls and shall allow dropped users to rejoin.

#### **3.8.1.19. Commercial Net**

When vocoders are required, the RDCS shall provide a Radio/Telephone Interface Unit (RTU) to link with commercial telephone networks. The RTU shall:

- a. Provide unattended operation.
- b. Permit dial-out from the radio.

#### **3.8.1.20. Relays**

The RDCS relays and associated install equipment shall:

- a. Be mounted for ground level access.
- b. Operate from local power (110/220 VAC- 50/60 Hz).

#### **3.8.1.21. Interfaces**

The RDCS shall:

- a. Provide full functionality of an EIA RS-232 / RS-422 Serial communication port.
- b. Provide an IEEE-1394 High Performance Serial Bus if necessary to support any of the system components.
- c. Be capable of interfacing to laptops, electronic clipboards, or other serial interface devices for the transmission of reports and AAR files.

- d. Interface connectors and cables shall be able to sustain severe field use.

### **3.8.1.22. Network Management**

The RDCS shall have a network monitoring capability for network administrators at the TOMC. The following characteristics shall be met.

- a. Fault: The RDCS network Fault/ Connection management capability shall cover connection topology and fault status.
- b. Performance: The RDCS network Performance management capability shall cover throughput, collisions, retransmission, and bottleneck analysis.
- c. Configuration: The RDCS network Configuration management capability shall cover definition of end points, characteristics of equipment in service.
- d. Security: The RDCS network management shall provide the capability to set-up and monitor security requirements.

### **3.9. Player Units (PUs)**

The DRTS system uses PUs to instrument and capture data from instrumented vehicles (IPURs), helicopters, and Dismounted Trackers (DMTs). The PU requirements are described in the IPUR Perf Spec PRF-PT-765, DMT Perf Spec PRF-PT-767, and shall also meet the requirements of this document including but not limited to Information Assurance, Security, Safety, Electronic and System Protection, Environmental, and Logistics.

The DRTS system shall provide a Range Control System for DRTS PUs and Field Support Equipment (FSE). The Range Control System shall provide up to 112 High Definition (HD) video feeds simultaneously. The range coverage signal to noise ratio shall be 20 dBm or better for any lane location and administration areas as determined by the Government.

#### **3.9.1. PU Coverage Area**

Throughout the coverage areas, the PU RDCS shall:

- a. Provide the capability to communicate with the PU Transceiver when in an active run 100% of the time.
- b. Provide the capability for bidirectional communications.
- c. Provide the bandwidth capability to support up to 28 combat vehicles transmitting eight video channels, audio, and combat vehicle specific data per IPUR with a maximum delay of one second (1s) from IPUR to CT.
- d. Provide coverage for gunnery type runs based on one vehicle per lane.
- e. Provide coverage for Convoy Live Fire (CLF) operations for up to six vehicles with any combination of Bradley, Abram, Stryker and other wheeled vehicles. CLF configuration coverage is required at the range main lanes, baseline, crossover trails and CLF roads. For testing purpose the CLF configuration to be used is 1 Abram Tank, 1 Bradley, 1 Stryker ICV, 1 Stryker MGS and 2 wheeled vehicles with 100 meters (100m) separation.

- f. Provide network nodes as required within the Free Maneuver Area. Network nodes shall be installed at targets emplacements or field camera towers within that area.
- g. Provide the capability to generate GPS position data 100% of the time (when there is a functioning GPS signal) around the periphery of the AGI village, Live-Fire Villages and Urban Clusters Areas and access roads to these areas.

### **3.10. Firmware**

All DRTS media shall be Unclassified. The DRTS system shall:

- a. Sanitize all media prior to disposal or release from organizational control.
- b. Only use authorized techniques and procedures IAW NIST SP 800-88 and AR 25-2.
- c. Utilize sanitization mechanisms with the strength and integrity commensurate with the security category or classification of the information, as defined in AR 25-2.

### **3.11. Electromagnetic**

The DRTS system shall be compatible with the electromagnetic and physical environment of the training areas and devices.

#### **3.11.1. Electromagnetic Environmental Effects (E3)**

DRTS HW shall be electromagnetically compatible with all subsystems and equipment found at the training ranges. DRTS HW shall operate in the electromagnetic environment (EME) described below without being a source of electromagnetic interference. All equipment (NDI, COTS, modified COTS, new design) shall operate in the electromagnetic environment (EME) described below without being a source of electromagnetic interference or a victim of site/location generated electromagnetic emissions, whether radiated or conducted. The DRTS site is expected to be a high electromagnetic noise environment for radiated energy. The equipment site is an active military training range with an active airfield operation. The equipment site contains electromagnetic effects from licensed/authorized RF emitters, lightning storms, power line transients, and electrostatic fields generated by human operators and maintainers. Thus, considerable electromagnetic emissions from numerous electromagnetic emitter sources, both intentional (i.e. radar, radio both fixed and mobile) and unintentional (i.e. ignition noise), will be adjacent to the equipment.

#### **3.11.2. Electromagnetic Compatibility (EMC)**

The EMC shall not interfere with the system operational performance requirements. The expected Electromagnetic Environment (EME) at the operational site is 50 V/m (RMS) in the frequency range of 10 KHz to 10 GHz.

### **3.11.3. Electromagnetic Radiation Hazards (EMRADHAZ)**

The system equipment design shall protect personnel, fuels, and ordnance from hazardous effects of electromagnetic radiation.

### **3.11.4. Non-Developmental Items (NDI) and Commercial Items**

NDI and commercial items shall:

- a. Meet E3 requirements.
- b. Meet the RDCS operational performance and E3 requirements.
- c. Demonstrate the ability to detect maintainability, accessibility, and testability degradation that would affect the safe E3 operation at the installation site.

### **3.12. Cybersecurity (CS)**

DRTS components shall be assessed and authorized to operate at a Confidentiality (low), Integrity (low), and Availability (low) level of Low, Low, Low. System design shall incorporate security compliance reporting capabilities including the Continuous Monitoring Tool (CMT) and the Inventory Reconnaissance Tool (IRT) that allows local staff at deployed sites to collect information to be submitted to PM ST. All DRTS components shall have applicable Cybersecurity controls required by DODI 8510.01 and AR 25-2, and IAW the current DRTS SSP, Implementation Plan, and supporting RMF documentation. These controls shall include, but are not limited to:

- a. All required Firewalls and Routers.
- b. All Cybersecurity or Cybersecurity-enabled components shall be on the National Information Assurance Partnership (NIAP) approved products list or must be in Common Criteria evaluation criteria. All WS shall utilize the most current approved version of Windows 10. All Windows servers shall utilize the most current approved version of Windows Server 2016 (or 2019).
- c. Encryption for all wireless connections transmitting sensitive data needs to utilize Federal Information Processing Standards (FIPS) 140-2 (for Unclassified) validated encryption modules as specified in RMF documentation.
- d. Current Government approved anti-virus SW installed on all servers and WSs in order to pass Cybersecurity test requirements at the time of integration.
- e. A backup and recovery capability and procedure shall be provided and validated per 8510.01.
- f. All components of the system shall be capable of being periodically updated for STIG compliance IAW the DRTS Information Assurance Vulnerability Assessment (IAVA) Management Plan detailed in the DRTS SSP.
- g. DOD Approved Ports, Protocols, and Services (PPS) shall be documented and maintained for all routed interfaces.
- h. All components shall be configured to meet the appropriate Security Technical Implementation Guides (STIGs) and System Security Requirements Guide (SRGs).

### 3.13. Security

The system shall prevent inadvertent disclosure of any unclassified or sensitive information and provide safeguards to prevent unauthorized access to the system or information used by the system. The system shall:

- a. Limit all CS and CS-enabled Government-off-the-Shelf (GOTS) IT products to those products that have been evaluated by the National Security Agency (NSA) or IAW NSA approved processes.
- b. Limit the acquisition of all CS and CS-enabled COTS IT products to those products that have been evaluated or validated through one of the following sources: the International Common Criteria (CC) for Information Security Technology Evaluation Mutual Recognition Arrangement, the NIAP Evaluation and Validation Program, or the FIPS validation program.
- c. Ensure the technical system features ensure that recovery is done in a secure and verifiable manner.
- d. Utilize DOD STIGs and SRGs as the primary source for security configuration or implementation guidance for the deployment of newly acquired CS and CS-enabled IT products that require use of the product's CS capabilities. If a DOD reference document is not available, the following are acceptable in descending order as available: (1) Commercially accepted practices (e.g., SANS); (2) Independent testing results (e.g., ICSA); or (3) Vendor literature.
- e. Utilize NIST FIPS 140-2 validated cryptography (e.g., DOD PKI class 3 or 4 token) to implement encryption (e.g., AES, 3DES, DES, Skipjack), key exchange (e.g., FIPS 171), digital signature (e.g., DSA, RSA, ECDSA), and hash (e.g., SHA-1, SHA-256, SHA-384, SHA-512) where required and described in the current SSP and supporting documents.
- f. Not utilize binary or machine executable public domain SW products and other SW products with limited or no warranty (i.e. freeware or shareware) in DOD information systems unless these products are necessary for mission accomplishment and there are no cost effective alternative IT solutions available. Such products shall be assessed for information assurance impacts, and approved for use by the Approving Official (AO). The assessment shall address the fact that such SW products are difficult or impossible to review, repair, or extend, given that the Government does not have access to the original source code and there is no owner who could make such repairs on behalf of the Government.
- g. Comply with DOD requirements for ports, protocols, and services guidance where applicable.
- h. At a minimum, utilize medium-robustness COTS CS and CS-enabled products to protect sensitive information when the information may transit public networks or the system handling the information is accessible by individuals who are not authorized to access the information on the system.
- i. Provide that system initialization, shutdown, and aborts ensure that the system remains in a secure state.

- j. Require boundary defense mechanisms, to include firewalls and network Intrusion Detection Systems (IDS), be deployed at key points in the network, as required.
- k. Be compliant with established DOD connection rules and approval procedures.
- l. Include the following Audit records.
  - 1) User ID.
  - 2) Successful and unsuccessful attempts to access security files.
  - 3) Date and time of the event.
  - 4) Type of event.
  - 5) Success or failure of event.
  - 6) Successful and unsuccessful logons.
  - 7) Denial of access resulting from excessive number of logon attempts.
  - 8) Blocking or blacklisting a user ID, terminal or access port and the reason for the action.
  - 9) Activities that might modify, bypass, or negate safeguards controlled by the system.
- m. Provide tools for the aggregation and review of audit records and for report generation from audit records.
- n. Apply all applicable DOD STIGs and SRGs.
- o. Utilize good engineering practices with integration of COTS, GOTS, and custom developed solutions for incoming and outgoing files, such as parity checks and Cyclic Redundancy Checks.
- p. Protect against unauthorized access, modification, and deletion.
- q. Implement virus protection that includes a capability for automatic updates for all Servers, WSs and mobile computing devices (i.e. laptops) within the RMF authorization boundary.
- r. Implement IAW DOD wireless policy, all wireless computing and networking capabilities from WSs, laptops, handheld computers, cellular phones, or other portable electronic devices.
- s. Disable by changing factory defaults, settings, or configurations prior to issue to end users for all wireless computing capabilities internally embedded. Wireless computing and networking capabilities shall not be independently configured by end users.
- t. Produce, control, and distribute using NIST approved key management technology and processes all symmetric keys as required by the DRTS SSP.
- u. Produce, control, and distribute Asymmetric Keys using DOD PKI Class 3 certificates or pre-placed keying material as required by the DRTS SSP.
- v. Accomplish identification and authentication using the DOD PKI Class 3 certificate and HW security token (when available) as required by the DRTS SSP.

### **3.13.1. System Access**

System access shall meet the following requirements.

- a. The system security design incorporates best security practices such as single sign-on, tokens, and other approaches as described in the DRTS SSP.
- b. Successive logon attempts shall be controlled using one or more of the following:
  - 1) Access is denied after multiple unsuccessful logon attempts.
  - 2) The number of access attempts in a given period is limited.
  - 3) A time-delay control system is employed. If the system allows for multiple logon sessions for each user ID, the system provides a capability to control the number of logon sessions.
- c. All users shall be warned that they are entering a Government information system and provided with appropriate privacy/security notices to include statements informing them that they shall be subject to monitoring, recording, and auditing.
- d. DOD information system access is gained through the presentation of an individual identifier (e.g., a unique token or user login ID) and password. For systems utilizing a logon ID as the individual identifier, passwords shall be, at a minimum, a case sensitive 8-character mix of upper case letters, lower case letters, numbers, and special characters, including at least one of each (e.g., emPagd2!). Deployed/tactical systems with limited data input capabilities shall implement the password to the extent possible.
- e. System mechanisms shall be implemented to enforce automatic expiration of passwords and to prevent password reuse all factory set, default or standard-user IDs, and passwords shall be removed or changed.
- f. Authenticators shall be protected commensurate with the classification or sensitivity of the information accessed, which shall not be embedded in access scripts or stored on function keys. Passwords shall be encrypted both for storage and for transmission.
- g. Unless there is an overriding technical or operational problem, WS screen-lock functionality shall be associated with each WS, as required by the SSP. When activated, the screen-lock function places an unclassified pattern onto the entire screen of the WS, totally hiding what was previously visible on the screen. Such a capability shall be enabled either by explicit user action or by a specified period of WS inactivity (e.g., 15 minutes). Once the WS screen-lock SW is activated, access to the WS shall require knowledge of a unique authenticator. A screen lock function shall not be considered a substitute for logging out (unless a mechanism actually logs out the user when the user idle time is exceeded).

### **3.13.2. Portable Electronic Devices (PEDS)**

PEDS are defined by the DOD as any non-stationary electronic apparatus with the capability of recording, storing, and/or transmitting information. This definition includes, but is not limited to cellular phones, e-mail devices, audio and video recording devices, tablet, and laptop computers. These devices shall satisfy the following:

- a. Wireless devices such as laptops and tablet connections shall be included in the updated DOD RMF Authority to Operate (ATO) package currently established, and signed by the AO. A thorough and comprehensive requirements validation, risk analysis, implementation, and migration plan shall be included within the required RMF package where required. Wireless connectivity shall not be authorized if the wired infrastructure that is to be extended is not authorized.
- b. Unused wireless computing capabilities internally embedded in interconnected DOD IT assets shall be disabled by changing factory defaults, settings or configurations prior to issue to end users.
- c. Wireless computing and networking capabilities shall not be independently configured by end users.
- d. Implement identification and authentication measures at both the device and network.
- e. For data at rest, PEDs shall use file encryption that is validated a meeting FIPS 140-2 requirements and as described in the DRTS SSP.
- f. All wireless devices including commercial unlicensed devices must be coordinated with the Army Spectrum Management Office (ASMO) and the local Army Frequency Manager prior to purchase.
- g. All wireless devices procured with Army funds must be certified for spectrum supportability through the Military Communications Electronics Board (MCEB) per DODD 5000.1 and AR 5-12.
- h. All applicable DISA STIGs and SRGs shall be applied to mobile devices.
- i. The use of personal e-mail (view and/or download) on a DRTS-controlled mobile device is prohibited.
- j. User owned personal data (i.e., music files, pictures, and movies) shall not be installed without authorization from the AO.
- k. Authorized users shall not connect to any social media web sites (i.e., Facebook, twitter).
- l. Personally owned or contractor owned mobile devices are prohibited to transmit, receive, store, or process DOD information or connect to DOD networks.
- m. Devices that store or process data (camera, cellphone, two-way radios, etc.) are not authorized as DRTS-controlled mobile devices.
- n. The use of Geo-Location (GPS) aware applications to save or transmit the location of the device are prohibited.
- o. DRTS-controlled mobile devices shall not be connected to personally owned computers.
- p. DRTS-controlled mobile devices shall have services such as photo, video, voice recording, 802.11 (Wi-Fi), 802.15 (Bluetooth), and other wireless technologies disabled.

- q. Non-Enterprise activated DRTS-controlled mobile devices are not authorized to connect to DOD networks or to DOD computers connected to DOD networks.

### **3.14. System Safety**

The contractor design approach shall ensure that the system, both COTS and GOTS modified/developed under this contract, is safe to operate and maintain and presents no uncontrolled safety, health, or environmental hazards to operators and maintainers throughout the life cycle of the system.

#### **3.14.1. Environmental Safety**

The contractor shall:

- a. Ensure that the system is safe to operate and maintain.
- b. Present no uncontrolled safety, health, or environmental hazards to operators and maintainers throughout the life cycle of the system.
- c. Comply with 29 CFR 1910, the National Fire Protection Association Codes, including hazards to users, operators, maintainers, and personnel adjacent to the system.
- d. Provide fail-safe features for safety of personnel during installation, operation, maintenance, testing, support activities, and disposal.
- e. Certify COTS equipment as meeting the requirements of a nationally accredited safety-testing laboratory for its intended use (i.e., UL, CSA), or host nation equivalent.
- f. Mark training equipment that can be mistaken for tactical equipment as "FOR TRAINING USE ONLY".

#### **3.14.2. Electrical Safety**

Electrical circuitry and installation shall:

- a. Comply with the requirements of the National Electric Code (ANSI/NFPA 70-2002).
- b. Be designed and installed with danger, caution, and warning signs. These signs shall be IAW ANSI Z535.3-98 and ANSI Z535.4-98 to warn user personnel of specific hazards.
- c. Sufficiently separate batteries from electronic components to prevent damage from corrosion.

#### **3.14.3. Hazardous Materials**

The contractor shall:

- a. Use non-toxic/environmentally acceptable alternatives whenever possible from a cost effectiveness and operational point of view.
- b. Not incorporate hazardous material, such as asbestos, glass fiber materials (as the outer surface or covering on cables, wire, or other items that may cause skin irritation to operating personnel); Halon or other Ozone-depleting

substances; or Polyvinyl Chloride (PVC) materials within crew or personnel occupied compartments.

- c. Install a caution note alerting maintenance personnel whenever maintenance procedures require access to glass fibers, such as insulation.
- d. Preclude exposure of personnel or the environment to excessive levels of toxic, carcinogenic, or otherwise hazardous materials as defined by the Occupational Health and Safety Administration (OSHA), Environmental Protection Agency (EPA), and the Department of Transportation (DOT).

#### 3.14.4. Personnel Safety

The design shall:

- a. Provide maximum safety to personnel and system equipment when installing, operating, adjusting, and maintaining the equipment.
- b. Locate cables to preclude tripping hazards or damage to cables.
- c. Conform to MIL-STD-1474 noise limits.
- d. Include the design, install, and label equipment and transit cases housing equipment to enable safe handling and lifting.
- e. Conform to the following single person lift limits:

Handling Function	1-person Lift (male/female) Lbs.	2-Person Lift Lbs.	4-Persons Lift Lbs.
Equipment lifted less than 5 feet above the floor	37	74	128
Equipment lifted less than 3 feet above the floor	44	88	154
Equipment designed to be carried 33 feet or less	42	84	147

#### 3.14.5. Mechanical Safety

The system design shall:

- a. Provide guards or safety devices on moving parts to prevent mechanical injury.
- b. Round edges and corners.
- c. Be free from burrs.
- d. Provide system center of gravity that is stable and easy to handle.

#### 3.14.6. Antenna Safety

The Antenna Safety design shall:

- a. Have tip caps or other suitable design fixture to prevent puncture hazards to eyes, etc., where personnel are likely to be exposed to such hazards.

- b. Be coated with a dielectric material to insulate against at least 10,000 volts Root Mean Squared (RMS).
- c. Provide adequate lightning protection.
- d. Have the following design features for all fixed, semi-permanent, and mobile facilities that incorporate antenna tower/masts:
  - 1) Antenna masts shall incorporate a ground stud to permit secure attachment of a ground strap/rod.
  - 2) Lead-in wires require discharge units (lightning arrestors) on each conductor or enclosure in a continuous metallic shield that is effectively grounded; coaxial cable lead-in may be used as is if the outer shields are grounded at both ends.
- e. Protect personnel from accidental contact with antennas and other devices that carry RF voltage to burn or injure personnel. Microwave or RF radiation signs shall be permanently affixed to warn personnel of danger zones.

### **3.14.7. Battery Box Design Safety**

Battery enclosures shall:

- a. Prevent electrolyte from being expelled in the event of battery leakage or venting.
- b. Provide battery box venting to minimize gas build-up.
- c. Not leak explosive or harmful battery gases into the equipment or any other source of ignition.
- d. Design lithium battery enclosures to preclude major system damage or serious personnel injury in the event of a violent gas venting or rupture of battery cells.

### **3.14.8. Electronic and System Protection**

#### **3.14.8.1. Electrical Surge Protection**

The system shall provide surge protection devices into the DRTS baselines. The surge protection shall be sized and appropriate for all of the equipment utilized.

#### **3.14.8.2. Electrical Grounding**

The DRTs system shall be grounded IAW the requirements defined in ANSI/NFPA 70-2001 requirements.

#### **3.14.8.3. Lightning Protection**

The system shall provide lightning protection for the entire range and complex of facilities. The system shall employ an ion dispersal system in conjunction with any lightning arresters or suppressors you deem necessary. The lightning protection system shall be ballistic hardened (not damaged if repeatedly shot) and shall not create ricochets or fragments if shot. The components of the lightning protection system shall comply with the applicable portions of ANSI/NFPA 780-1997.

### **3.14.9. Environmental**

The equipment shall withstand the representative environment and physical conditions of the DRTS ranges. Field equipment shall be designed to withstand exposure to the tactical environmental conditions to ensure survivability in the field. Environmental qualification shall include vibration, shock, temperature, rain, immersion, dust, salt, and fog in compliance to MIL-STD-810G. These requirements shall be met by components located both inside and outside of Heating Ventilation and Air Conditioning (HVAC) controlled facilities. Materials selected shall withstand, without deterioration, the effects of the environment in which the equipment is operated, stored, and transported. The below requirements applies to all equipment.

- a. The system shall be designed to withstand the representative environment for its fielded location(s).
- b. The system shall be designed to withstand (without deterioration) environmental exposure during storage/shipping.
- c. The equipment shall withstand temperatures in storage/shipping as cold as minus 51° F.
- d. The equipment shall withstand temperatures in storage/shipping as hot as 145° F.
- e. The system's components shall be designed/configured to withstand the typical stresses associated with handling/transportation/reconfiguration of the system.
- f. The system's components shall be designed/configured to withstand the typical stresses associated with handling/transportation/reconfiguration of the system.
- g. All environmental condition requirements shall be compliant with their corresponding section of MIL-STD-810G requirements.

### **3.14.10. Indoor HVAC Controlled Facility Conditions**

DRTS equipment installed in facilities which maintain temperature and humidity control (e.g. the Control Tower and AAR theatre) shall meet the following:

- a. The equipment shall have a minimum of Ingress Protection of IP20.
- b. Internally mounted equipment enclosures shall be NEMA 1 complaint.
- c. The equipment shall be designed to be operated in a regulated internal climate controlled facility with an expected temperature range of 60°F to 80°F.
- d. The equipment shall designed to be operated in a regulated internal climate controlled facility with an expected relative humidity range of 20% to 75% +/- 5%, not to exceed 80% (non-condensing).

#### **3.14.10.1. Indoor Non-HVAC Controlled Facility Conditions**

DRTS equipment which is installed within a building which provides limited environmental protection from direct sun, rain, and wind shall meet the following: The core equipment within the training building equipment rooms may utilize rack mounted HVAC system to support the requirements in this paragraph as appropriate.

- a. The equipment shall withstand temperatures as cold as minus 40°F (-40°C).

- b. The equipment shall withstand temperatures as hot as 122°F (50°C).
- c. The equipment shall be capable of withstanding winds up to 35 mph.
- d. The equipment shall endure a relative humidity range from 10 to 95 percent (non-condensing).
- e. The equipment shall have a minimum of Ingress Protection of IP51.
- f. Internally mounted equipment enclosures shall be NEMA 12 compliant.
- g. All installed equipment and infrastructure shall prevent insect and animal intrusion.

### **3.14.11. Outdoor Conditions**

DRTS equipment installed outdoors without any protection from the environmental conditions (e.g. external cameras) shall meet the following:

- a. Temperature: MIL-STD-810G Method 501.5 (A1) (Operating +49° C/ Non-operating: +71° C).
- b. Temperature: MIL-STD-810G Method 502.5 (C1) (Operating -31° C/ Non-operating: -33° C).
- c. Solar Radiation: MIL-STD-810G Method 505.5.
- d. Withstand rain, sleet, snow and ice.
- e. Withstand wind gusts up to 70 mph.
- f. Endure a relative humidity range from 10 to 100 percent (condensing).
- g. Minimum of Ingress Protection of IP55 (with exception of the exterior camera).
- h. Field Cameras shall have Ingress Protection of IP66.
- i. Externally mounted equipment enclosures shall be NEMA 13 compliant.
- j. Prevent insect and animal intrusion into installed equipment and infrastructure.

#### **3.14.11.1. Shock**

DRTS components and devices mounted on combat vehicles shall:

- a. Not be damaged when subjected to the specified shock spectrum of MIL-STD-810G, Method 516.6, Procedure I - Functional Shock.
- b. Not be damaged when subjected to the recommended drop test of Table 516.6-II and Procedure IV - Transit Drop (inside transit case).

#### **3.14.11.2. Vibration**

DRTS components and devices mounted on combat vehicles shall not be damaged when tested IAW MIL-STD-810G, Method 514.6, Categories 1-5.

#### **3.14.11.3. Humidity**

DRTS components and devices exposed to the elements shall not be damaged during operations under relative humidity conditions when tested IAW MIL-STD-810G Method 507.5.

#### **3.14.11.4. Rain and Immersion**

DRTS components and devices exposed to the elements, and all transit cases shall not be damaged when tested IAW MIL-STD-810G Method 506.5 (Rain) and 512.5 (Immersion). Those components and devices subjected to the immersion test shall not be subjected to the rain test.

#### **3.14.11.5. Sand and Dust**

DRTS components and devices exposed to the elements shall not be damaged when subjected to test IAW MIL-STD-810G, Method 510.5.

#### **3.14.11.6. Salt and Fog**

DRTS components and devices exposed to the element exterior surfaces, including transit cases, shall:

- a. Be treated to resist corrosion or deterioration.
- b. As a minimum performance requirement, these surfaces shall exhibit no blistering, lifting of the coating system, and substrate corrosion after being subjected to a 5% sodium chloride atomized spray as described in MIL-STD-810G, Method 509.5.

#### **3.14.11.7. Explosive Atmosphere**

Capability of operation in flammable atmospheres shall be demonstrated by certification or design analysis IAW MIL-STD-810G, Method 511.5.

### **3.15. Logistics**

An integrated logistics process shall be used to develop the best support requirements for the DRTS. The logistics support approach shall be implemented to maximize the cost effective life cycle operations and maintenance support. Tradeoffs may be required in order to provide a DRTS that minimizes life cycle cost, is operable, supportable, sustainable, and environmentally sound.

#### **3.15.1. Maintenance Concept**

Life Cycle Contractor Support (LCCS) shall be used to support the DRTS. There are currently 2 levels of maintenance support: On-site and Off-site. On-site Field Maintenance relies on line replaceable unit (LRU) and component replacement and related maintenance activities. Off-site support shall reflect Depot level activities. The maintenance concept for the DRTS components and sub-components consist of the levels of maintenance described below.

##### **3.15.1.1. Levels of Maintenance**

The levels of maintenance for the DRTS shall consist of 2 levels, Organizational (On-line and Off-line) and Depot. On-line level maintenance consists of scheduled maintenance and corrective maintenance, which is performed on-line (on the training equipment as a whole). Sustainment level maintenance consists of combining the General Support (GS) and Depot maintenance activities. Sustainment Maintenance is a repair-and-return to the supply system and is performed on faulty repairable items (e.g.

circuit cards, power supplies, etc.) which have been functionally and physically removed from the training equipment as part of on-line level maintenance. Depot level maintenance consists of repair of repairable items that are beyond the repair capability of off-line level maintenance. COTS, Original Equipment Manufacturer (OEM) and Trainer Peculiar Equipment (TPE) shall be included in each level of maintenance.

- a. Field On-line Maintenance - On-line maintenance activities shall:
  - 1) Verify that the training and range equipment is ready for training by performing appropriate tests and inspections.
  - 2) Isolate training equipment malfunctions to faulty parts or assemblies using standard test equipment, test procedures, computer based diagnostics, maintenance documentation, inspection and by substitution when an ambiguity group is identifiable.
  - 3) Remove and replace faulty parts in a manner that minimizes training and range equipment downtime followed by verification of the repair using the training equipment as a test bed. Verify that the training equipment returns to its operable state.
  - 4) Perform scheduled maintenance during non-training hours, as required.
  - 5) Isolate and document SW related failures.
- b. Field Off-line Maintenance shall:
  - 1) Repair of those failed assemblies that can be repaired using only standard test equipment, commercially available maintenance data (usually OEM developed), and off-the-shelf replacement parts.
  - 2) Perform fault isolation and repair of failed repairable assemblies on-site through the use of test equipment and maintenance documentation.
- c. Sustainment Level Maintenance - Sustainment level maintenance shall consist of commercial repair/overhaul of failed assemblies that are beyond the repair capability of Field maintenance. The need for depot maintenance shall be minimized through design control of TPE items and special consideration for the support concept during the selection process of Commercial Item equipment.

#### **3.15.1.2. Qualitative Maintainability**

General maintainability characteristics of the equipment added or modified as a result of required DRTS modifications or upgrades shall be as specified in the following paragraph.

#### **3.15.1.3. Special tools**

There shall be no need to use special tools for equipment maintenance unless common tools are inadequate. Special tools shall be retained in holders provided inside of the equipment near where the tools are normally used. Identify any special tools during the first design review for Government approval.

#### **3.15.1.4. Built-In Test (BIT)**

The training equipment design shall include built-in, non-continuous, fault detection and isolation test to detect performance degradation and failures for all equipment (Commercial Items, Government Furnished Property (GFP), Contractor Acquired Property (CAP), TPE, etc.) The BIT shall be manually or digitally invoked and shall furnish the means of determining the functional status of the DRTS and subsystems down to the individual LRU.

#### **3.15.1.5. Accessibility**

The DRTS accessibility shall provide the means to access internal parts, terminals, and wiring, for adjustments, required circuit checking, and the removal and replacement of maintenance parts. Accessibility for testing shall not apply to parts located in non-repairable assemblies. For routine servicing and maintenance, unsoldering of wires, wire harnesses, parts, or subassemblies shall not be required in order to gain access to terminals, soldered connections, mounting screws, and the like. The following additional requirements shall also apply.

#### **3.15.1.6. Parts**

Replaceable parts shall be readily removable. For example, replaceable parts shall not be permanently mounted by means such as rivets, spot welding, or hard curing compounds. No unsoldering of connections shall be necessary in order to remove front panels or sub-chassis for maintenance purposes.

#### **3.15.1.7. Assemblies**

All parts shall be readily accessible for maintenance. Tracks, rollers, hinges, pivots, or a combination thereof shall be installed for providing accessibility to units, assemblies, subassemblies, and parts. Locking devices shall be provided to lock the chassis in the servicing position and in the fully opened and fully closed positions. Each major assembly, subassembly, and unit shall permit access to its interior components and parts for maintenance. It shall not be necessary to displace or remove wires, cables, subassemblies, or assemblies in order to gain access to mounting screws, test points, adjustment points, lubricating points, and the like. Where visual inspection is necessary and open access is not feasible, transparent access panels shall be used. The placement of parts shall provide space for the use of test probes and maintenance tools. Assemblies subject to replacement or service shall not be permanently fastened.

#### **3.15.1.8. Modular assemblies**

Modular assemblies such as circuit boards shall be equipped with connectors so that they may be removed without de-soldering. All modular assemblies shall be designed so that they can be inserted into the equipment in 1 position only. All sockets within each assembly shall be oriented in the same direction and positioned so that they are visible. Modular circuits shall be grouped in functional units.

### **3.16. Facilities**

The DRTS shall operate within the Government-Furnished Facilities (GFF) or Range Tower identified in the contract. The DRTS design characteristics shall minimize the need for modifications to the GFF. Any DRTS design requiring a change to GFF shall be presented at the first design review for Government concurrence/approval. All connections between the training system equipment and the GFF utility and grounding points shall be provided in accordance with applicable codes and regulations. The equipment shall be designed to utilize the facility as it currently exists. The equipment design shall not require any architectural or structural modifications. The equipment design may require electrical or mechanical modifications so long as the modifications do not require an increase in capacity.

### **3.17. Reliability**

The DRTS System shall satisfy the following reliability requirements:

- a. Provide mission operating cycle for the PU equipment of 20 days.
- b. Provide a minimum acceptable Mean Time Between Essential Function Failure (MTBEFF) for the PU of 1,000 hours. This requirement excludes Government Furnished Property (GFP).
- c. The reliability requirements test shall be conducted in accordance with MIL-HDBK-781, Test Plan XIV (lower test MTBF limit), and the approved reliability test procedures.
- d. The sample size for the qualification test shall not be less than 5 units and not greater than 20 units.

### **3.18. Maintainability**

The DRTS System shall satisfy the following maintainability requirements:

- a. Provide a Mean Corrective Maintenance Down Time (MCT) of 30 minutes or less for the performance of on-equipment maintenance.
- b. No special tools required for the maintenance of the system.

### **3.19. Human Engineering**

The DRTS System shall:

- a. Provide a design to enhance operational efficiency, interaction, and realism; while meeting all applicable safety, health, and human factor requirements for training devices.
- b. Comprehensively integrate human characteristics into system definition, design, development and evaluation to optimize performance of human in the loop.
- c. Avoid an increase in required manpower, while easing physical tasks, time required for maintenance as well as minimizing the chance of operator/maintainer error or accident.
- d. Consistent with Joint Technical Architecture Human-Computer Interface Standards.
- e. Allow for Operators and rotational unit users to operate and use DRTS Components safely and effectively.

- f. Provide SW with a common man-machine interactive display and control interface for all SW functions in order to maximize the efficiency of the operator's use.
- g. Provide a design and functionality IAW the following sections of MIL-STD-1472: Control 5.1 (Control/display integration); 5.2 (Visual displays); 5.3 (Audio displays); 5.4 (Controls); 5.5 (Labeling); 5.6 (Anthropometry); 5.9 (Design for maintainer); 5.11.1 Portability of Load Carrying; 5.13 (Hazards and safety); 5.15 (User-computer interface).
- h. Not create any new operator military occupational specialty (MOS).
- i. Not create additional skills and other personnel qualitative increases.
- j. Allow for operational tasks to be performed by the Soldiers, exercise controllers and analysts who may be active duty, Department of the Army Civilian (DAC), or contractor personnel.

#### **4. Verification**

This paragraph includes all verifications to be performed to determine that the system offered for acceptance conforms to all requirements in paragraph 3 of this specification. Unless otherwise specified, all inspections shall be performed in prevailing environmental conditions that define normal range operations.

The system submitted for Verification shall be capable of operating the GFISW but shall not require correction of any SW performance. The table below identifies which requirements are primarily SW controlled. The SW requirements shall only be evaluated for the system ability to execute the GFI SW.

#### **Methods of Verification include:**

- a. Examination (E). An element of verification and inspection consisting of investigation, without the use of special laboratory appliances or procedures, of items to determine conformance to those specified requirements which can be determined by such investigations. Examination is generally nondestructive and typically includes the use of sight, hearing, smell, touch, and taste; simple physical manipulation; mechanical and electrical gauging and measurement; and other forms of investigation.
- b. Analysis (A). An element of verification that uses established technical or mathematical models or simulations, algorithms, charts, graphs, circuit diagrams, or other specific scientific principles and procedures to provide evidence that state requirements were met.
- c. Demonstration (D). An element of verification that generally denoted the actual operation, adjustment, or re-configuration of items to provide evidence that the designed functions were accomplished under specific scenarios. The items may be instrumented and quantitative limits of performance monitored.

- d. Test (T). An element of verification and inspection that generally denoted the determination, by technical means, of the properties or elements of items, including functional operation, and involves the application of established scientific principles and procedures.
- e. Certification (C). An element of verification that that generally denotes or documents the prior conduct of formal test verification, and relies on documented test results, performance data, analytical data, or vendor documentation. The items require that the contractor certify that the requirements have been met.

## **Acceptance Test Structure**

### **In-Plant Test:**

The in-plant testing event is a formal government witnessed testing event, and is aimed at assessing the adequacy of the system to fulfill the requirements. During the In-Plant testing the complete functional capabilities of the final system components are tested following the test procedure, but utilizing audio, video, player unit, and targets simulators. The In-Plant testing is conducted before STT to ensure the system components are ready to be shipped to the site.

### **System Technical Test (STT):**

The System Technical Test is an on-site test where the contractor and the Government representatives test the system. During the STT, the initial and comprehensive requirements are tested using the test procedure. The STT is conducted before SOT to ensure the system is prepared to be tested by the Government. The STT shall include the following testing, at a minimum, to ensure full coverage of the requirements:

### **Auto-Start and Shutdown System Test, including all server room component status:**

These tests will confirm that all DRTS components can be started, shutdown, and restarted. The tests will be conducted using the AutoStart tablet located within the server room. The tablet can be used to determine the time it takes for the hardware and software to fully start or shutdown. The testing includes performing a system shutdown with master exercise deletion, followed by a system startup. Once this test is completed, a complete DRTS checkout is performed (including the SDT, RDE, SYSCON, EXCON, AAR, and THP) to ensure that the system is operating properly. Once the checkout is complete a system restart is conducted to show that data can be recovered from a scheduled shutdown.

### **Range Radio Communication System Test:**

The purpose of the Range Radio Communication System Test is verify the ClearCom Communication system and the SINCGARS radios are interconnected and working

properly. This test will be performed to ensure that all elements of the communication system from each workstation to the vehicles (using the SINCGARS), and each workstation to workstation are performing as intended.

#### **Dismounted Tracker Testing to include coverage testing:**

The purpose of the DMT test is to verify the DRTS hardware/software interaction with the DMT, including a coverage test to ensure the DMT stays connected to the RDCS throughout all areas on the range. The test also verifies that the DRTS software properly displays the DMT GPS position on the SAW map with the proper status and location. The ability to control the DMT using the Command and Control GUI will also be verified.

#### **SYSCON/Handheld Target Controller (HTC) target and BES testing:**

This test ensures that all target related components are properly installed and working for each type of target (MAT, MIT, SAT and SIT). All BES and target types are tested using the SYSCON and Handheld Target Controller (HTC), to ensure all controlling commands are working as intended. Similarly, target related response and messages will be evaluated to ensure the targets are properly providing the correct feedback. As part of this test target commands will be generated, target hits simulated, and the corresponding responses evaluated.

#### **IPUR Control Testing:**

The purpose of the IPUR test is to verify the IPUR data connectivity, and DRTS hardware/software interaction with the IPUR. The IPUR Control test case will verify that the DRTS software can send commands to the IPUR and receive the data transmitted from the IPUR. During the IPUR control test, the IPUR controls and commands are verified using the FSE software via two methods (SYSCON and FSE Laptop).

#### **IPUR Coverage Test and IPUR radio network nodes Saturation test:**

IPUR Coverage test will verify that the IPUR properly reports the GPS location, status of the IPUR, 1553 data transmissions and that video/audio is uninterrupted. The objective is to confirm IPUR connectivity to the relay and mesh points and successful transmission of data to the Control Tower throughout all required range areas thus making sure the IPUR nodes network provides the required coverage.

The collective scenario will be executed eight times using combat vehicles. The vehicles will rotate lanes after each run (forward and reverse) so that coverage is confirmed for every vehicle type in all lanes. This test will be executed two times on both channels using different vehicles for each test for a total of  $(\# \text{ of course roads}) * (\# \text{ of vehicle type}) * 2$  runs.

The network node saturation test will verify the DRTS system can support up to 18 combat vehicles instrumented with IPURs. The range will utilize two channels with 14 IPURs on each channel. There will be eight IPURs at the install pad or baseline, four of them

being on channel 1 and the other four on channel 2. Four IPURs mounted on vehicles, two of them being on channel 1 and the other two on channel 2 and six IPURs standalone mounted downrange, three of them being on channel 1 and the other three on channel 2, for a total of 18 IPURs. All 18 IPURs will be verified as working from the SYSON in order to satisfy radio network nodes saturation requirements. Nine IPURs will be set up as a M2A3 Bradley (5 feeds) and nine as a M1A2 SEP Tank (7 feeds).

### **VSS Testing and Field Camera Controls:**

The Video Services Suite Test verifies that DRTS, Field Cameras, and Sight SW correctly interact when different run types are executed. The test also verifies all the Sight SW capabilities to include scenario execution, AAR creation, AAR execution, and THP creation. To verify the Sight SW, the following Scenarios are tested for ground combat vehicles: Crew Runs, Section Runs, Platoon Runs (CALFEX), utilizing the gunnery manual. For aviation: Aviation Crew, Aviation Section with 2 vehicles, and Aviation Platoon with four vehicles. The test also confirms that the field camera presets were setup correctly, and the field camera can be controlled by using the joystick, mouse/keyboard, and the video display panel. Finally, the test verifies the AAR execution layouts are correct.

### **System Saturation and Endurance Testing (SET):**

The IPUR Saturation and Endurance Test verifies that the DRTS software and Video System has the ability to execute a training exercise during saturated conditions, and for an extended period of time. The test uses a representative load to the system run cycle similar to half a battalion training cycle using dry and live-fire runs. The goal of this test is to create a realistic “worst case” load on the Range system to ensure proper handling of the additional load. The endurance portion of the test is based on 140 training runs for the ground vehicles including a combination of vehicle types, running both crew and collective tables and 70 runs for the aviation vehicles (crew and collective). In addition, the DRTS “exercise” capability is used to control the amount of data being processed by the system at any given time. SET will consist of importing a scenario, creating runs, executing runs, preparing AARs, presenting AARs and creating a THP at the same time or as close as possible. To simulate the required amount of players during SET the use of player unit simulators can be used (i.e. 14 IPURs with a set number of audio-video injectors into IPUR, AWSS simulators, UAS simulators).

The following table describes some of the run types that are used during SET:

BFV GT VIA Duallane
BFV GT VIB Duallane
Tank GT VIA Duallane
Tank GT VIB Duallane

ICV GT VIA Duallane
ICV GT VIB Duallane
BFV GT XIIA
BFV GT XIIB
Tank GT XIIA
Tank GT XIIB
CALFEX Day
CALFEX Night
AH64D/E VIA
AH64D/E VIB
UAS VIA
UAS VIB
CALFEX Day (Aviation / Ground Combined)
CALFEX Night (Aviation / Ground Combined)

**Aerial Weapon Scoring System (AWSS) Components testing:**

The purpose of the AWSS test is to demonstrate the Inter-Coastal Electronics, Inc. (ICE) Aviation Instrumentation System (AIS) integration with DRTS, and to conduct a communication coverage evaluation of the DRTS range complex. An AH64 will be used for these tests with an installed SMODIM that will communicate with the AIS system and provide position location data into DRTS representing an aircraft. The SMODIM video/audio data is captured in a Removable Memory Module (RMM) installed in each aircraft. The vehicle will traverse areas of the range to include the FARP area, the firing lanes, aerial firing points, convoy Live Fire course roads, Air-ground Integration Village and the Urban Cluster area, Position location data will be transmitted by the AH64. At the conclusion of the coverage test the RMM is then removed from the aircraft and the RMM data is ingested into DRTS for the purpose of presenting an AAR.

**AWSS Sensor Operation Test:**

The AWSS sensor operation testing consist of verifying operation of all the AWSS target types and AWSS FSE. The following list includes the AWSS target types:

- Aerial Weapons Scoring System (AWSS) Bullet Scoring Subsystem (BSS) on Stationary Armor Target (SAT)
- AWSS BSS on Moving Armor Target (MAT)
- AWSS Laser Scoring System (LSS) on SAT
- AWSS LSS on MAT
- AWSS Rocket Scoring Subsystem (RSS) on Steel target

For this test AWSS related commands will be sent to the AWSS subsystems via the SYSCON and AWSS Control Station Subsystem (CSS) laptop to ensure all are properly working. Similarly, AWSS subsystem related response and messages will be evaluated to ensure the AWSS subsystems are properly providing correct feedback.

### **Unmanned Aerial System (UAS) DRTS component testing:**

The purpose of this test is to verify the DRTS UAS components interact with the rest of the DRTS. For this test an Universal Ground Control Station (UGCS) accompany by an unmanned aerial vehicle (i.e. Shadow, Grey Eagle), needs to be present in the range. The DRTS UAS components are then connected to the UGCS to monitor the aircraft payload (video, crew audio, laser designation, and aircraft specific data). The test will include scenarios where the UAV is lasing the targets during crew and collective training events.

### **System Operational Test (SOT):**

The System Operational Test is the final acceptance of the system prior to fielding. The focus of the SOT is to perform an end-to-end testing; everything from scenario development, creating and executing training events/runs through qualification and collective runs. Create AARs, Present AARs to include IPUR video ingestion and THPs. The Government will conduct the SOT, on-site, using tactical vehicles under a live-fire environment to emulate an abbreviated training cycle. The successful presentation of the AAR will dictate Government acceptance. The SOT activities will be conducted in the same manner as they would be during operational use. The scenarios used during SOT include Stryker ICV GT VI, Stryker MGS GT VI, Bradley GT VI, Tank GT VI, Tank & Brad GT VII, Tank & Brad GT XII, Aviation VI, Aviation X, and CALFEX (utilizing all course roads). All of these scenarios/events are executed with a combination of day and night runs to complete a total of 64 runs.

#### 4.1. DRTS General Performance Requirements

Requirement:	E	A	D	T	C
The DRTS system shall be capable of operating the Government Furnished Equipment (GFE) software (SW).	X				
The contractor shall not be responsible for Government owned SW performance nor the correction of Government owned SW functionality.	X				

#### 4.1.1. Systems Start, Shut Down and Restart Requirements

Requirement:	E	A	D	T	C
The System Start, Shut Down, and Restart requirements shall apply to components installed in the Control Tower, to include Aerial Weapons Scoring System (AWSS) Control Station Subsystem (CSS), DRTS servers, Communications Systems (i.e. Clearcomm, SINCGARS), SYSCON WSs, EXCON WSs, and any other evaluation room workstation (i.e. EDC), as well as After Action Review (AAR) components to include the Podium workstations (PWS), Take-Home Package WS, and CMUR Ingest WS.	X				

#### 4.1.1.1. System Startup and Restart

Requirement:	E	A	D	T	C
The DRTS system shall have the capability for a full system startup where all applicable system components, system main servers, workstations (WSs) shall be started (hardware (HW) and Operating System (OS)).			X		
The DRTS system shall have the capability to be ready to execute their corresponding application SW in 30 minutes or less from full system start.			X	X	
The DRTS system shall have an Auto Start capability, which shall enable all Control Tower and AAR equipment to power up from a single location.			X		
The DRTS system shall start all server and WS applications within 20 minutes from full system start up.			X	X	
The DRTS system shall have all WSs ready for use in 1 minute or less from full system startup.			X	X	

#### 4.1.1.2. System Shut Down

Requirement:	E	A	D	T	C
The DRTS system components shall provide an orderly shutdown.	X		X		
The DRTS system components shall attain a powered-off condition within 20 minutes			X	X	

The DRTS system components shall not lose any database or configuration data	X		X		
The DRTS system shall have an Auto Shutdown capability, which shall enable all Control Tower and AAR Building equipment to power down from a single location.					
The DRTS system components shall leave the system in a state that can be re-started	X				

#### 4.1.2. Scalability

Requirement:	E	A	D	T	C
The DRTS system shall be designed for implementation for a Digital Multi-Purpose Range Complex (DMPRC).	X				
The DRTS system shall be designed for implementation for a Digital Multi-Purpose Training Range (DMPTR).	X				
The DRTS system shall be designed for implementation for a Battle Area Complex (BAX).	X				
The DRTS system shall be designed for implementation for a Digital Air/Ground Integration Range (DAGIR).	X				
The DRTS system shall be designed for implementation for an Aerial Gunnery Range (AGR)	X				

#### 4.1.3. Availability

Requirement:	E	A	D	T	C
The DRTS system shall be available during range operation 99% of the time.			X	X	
The DRTS system shall operate continuously for 22 days to support a ground battalion training cycle.			X	X	
The DRTS system shall have 1 range configuration day after the 11 <sup>th</sup> consecutive day of operation.			X		
The DRTS system shall enable Main Servers to be re-cycled after the 11 <sup>th</sup> consecutive day of operation with either all data flushed or with no data loss.			X		
The DRTS system shall sustain data due to loss of power, environmental control, or weather within the 11-day cycle			X		
The DRTS system shall utilize a maximum of 2 days for range maintenance after the 22 <sup>nd</sup> day of operation.			X	X	

#### 4.2. Control Tower

##### 4.2.1. General Design Considerations

Requirement:	E	A	D	T	C
The DRTS system shall utilize the Government Furnished Information (GFI) SW.	X				

The DRTS system shall utilizes CTIA, LT2 Product Line components, and commercial products.	X				
The DRTS system shall minimize specially developed SW or HW.	X				
The DRTS system shall have visual SW displays that conform to the CTIA Common Graphical User Interface (GUI) Style Guide and Framework.	X				
The DRTS system shall provide access to menus, icons, and other GUI devices through a pointing device and the keyboard ("hot keys" and function keys).	X	X			
The DRTS system shall have visual displays with scroll bars, zoom, or drag hands to ensure all displayed data is viewable.		X			
The DRTS system shall have operator error messages, which include the nature of the error, the correction method, and the name of the packages/object that generated the message.		X			
The DRTS system shall display formatting text tips to augment operator's understanding of displays; for example, displaying data constraints, format, and units when pointer is over the field.		X			
The DRTS system shall integrate displays through menus, icons, buttons, and other GUI devices		X			
The DRTS system shall have adjustable displays with operator palette control.		X			
The DRTS system shall have default palettes that are recoverable.		X			
The DRTS system shall have palettes (colors) annotated in the application such as standard colors for icons, symbology, event depiction, and other effects.		X			
The DRTS system shall be capable of saving application configuration changes as preferences and recovering those preferences for later use.		X			
The DRTS system shall have non-destructive display windows (i.e. the opening of an application shall not force the abnormal end of a running application).		X			
The DRTS system shall have the capability to overlap displays without corrupting data (e.g. closing a window shall automatically restore the underlying display.)		X			
The DRTS system shall refresh displays within 1 sec.		X	X		
The DRTS system shall display Security Classification, date, and time at all times.	X	X			
The DRTS system shall allow operators the option of displaying exercise time (time since start of exercise) and one of the following: local time, Coordinated Universal Time (UTC), or Greenwich Mean Time (GMT).		X			

The DRTS system shall allow the time format be selectable at any time.	X		X		
The DRTS system shall ensure the time in the system is traceable to UTC (GPS) or UTC maintained by the U.S. Naval Observatory.	X		X		
The DRTS system shall have all servers and WSs compliant with the current DRTS System Security Plan (SSP).	X				

#### 4.2.2. Control Tower System Performance

<b>Requirement:</b>	<b>E</b>	<b>A</b>	<b>D</b>	<b>T</b>	<b>C</b>
The DRTS Control Tower shall be equipped to conduct exercises at that fixed location.	X		X		
The DRTS Control Tower shall enable all WSs the capability of executing all required Control Tower SW and functionality.	X		X		
The DRTS Control Tower shall have all the servers and WS required to support the GFE DRTS SW.	X				
The DRTS Control Tower shall have a 50% spare CPU and memory capacity for Servers and WS.			X	X	
The DRTS Control Tower shall be in a network controller and relay environment.	X		X		
The DRTS Control Tower shall contain all equipment required for hosting the Control Tower database including, AWSS CSS Real Time Processes (RTP), Aviation Data Translators (ADT), logging of exercise data, interfacing range components to the Range Digital Communications System (RDCS), the technical operations, maintenance SW, video/audio recording, and playback.	X		X		
The DRTS Control Tower shall ensure each WS to have the capability to create and read commonly available removable media (e.g. CD-R, CD-RW, and DVD-RW).			X		
The DRTS Control Tower shall utilize media via industry standard parallel or serial interfaces (i.e. Small Computer Systems Interface (SCSI), Fire Wire (IEEE1394), and Universal Serial Bus (USB)).	X		X		
The DRTS Control Tower shall ensure each WS has the necessary user input and display devices required to operate.	X				
The DRTS Control Tower shall ensure all WSs and associated equipment shall support system security controls.	X				
The DRTS Control Tower shall have headsets and distribution equipment for communicating with other WSs and radio systems.	X				
The DRTS Control Tower shall have access to tactical/administrative radio systems via the WSs.	X				

The DRTS Control Tower shall have display HW capable of displaying the exercise area (4km x 6km for DMPC and 2.5km x 5km for other DRTS range types) 1:25,000 Arc Digitized Raster Graphics (ADRG) map at a 2.5X zoom-in.	X				
The DRTS Control Tower shall have graphics cards capable of 3D graphics (e.g. rendering, texturing, and Z-buffering) using Commercial Off-The-Shelf (COTS) graphics formats (e.g. DirectX, OpenGL).	X				
The DRTS Control Tower shall enable back-up and archival of data (Hard Drive or CD).	X	X			
The DRTS Control Tower shall have printer(s) for graphics and text printout in black-and-white and color.	X				
The DRTS Control Tower shall have a Weather Station capable of showing the Barometric Pressure, Wind Speed, Air Temperature, & Wind Direction.	X	X			
The DRTS Control Tower shall integrate the GFE BFT/BFT2 and MIL-STD-188-220 or satellite terminals.	X	X			
The DRTS Control Tower shall have the ability to interface with SINCGARS voice and Push-To-Talk (PTT) distribution.	X	X			
The DRTS Control Tower shall save separate Uninterruptible Power Supplies (UPS) for all equipment or a single UPS with power conditioning as the source of all equipment power.	X				
The DRTS Control Tower shall provide a UPS with enough backup power to execute an orderly power shutdown. (Orderly power shutdown is defined as successful if all data and states are saved as well as successful resumption of the training scenario from the point it was halted due to the loss of power.)	X	X			
The DRTS Control Tower shall have the Audio/Video interfaces necessary to ingest aircraft recorded audio and video from the Aviation Mission Planning System (AMPS) for AAR.	X	X			

#### 4.2.2.1. Workstations (WS)

Requirement:	E	A	D	T	C
The DRTS WSs shall control and manage the DRTS training system.			X		
The DRTS WSs shall be configurable as a Technical Operations and Maintenance Control (TOMC) WS.			X		
The DRTS WSs shall be configurable as a Range Safety Officer (RSO) WS.			X		
The DRTS WSs shall be configurable as a System Control (SYSCON) WS.			X		
The DRTS WSs shall be configurable as a Crew Evaluator WS (CEWS).			X		

The DRTS WSs shall be configurable as a Presentation WS (PWS).			X		
The DRTS WSs shall be configurable as a Take Home Package (THP) WS.			X		
The DRTS WSs shall be configurable as an Ingest WS, as required.			X		
The DRTS WSs shall be configurable to connect with interface devices such as mouse, keyboard, joysticks or any other required devices at the WS desks.			X		

#### 4.2.2.2. Operational Mode

<b>Requirement:</b>	<b>E</b>	<b>A</b>	<b>D</b>	<b>T</b>	<b>C</b>
The DRTS Control Tower shall be modular and expandable.	X				
The DRTS Control Tower shall support a free maneuver area.	X				
The DRTS Control Tower shall operate continuously for 22 days.			X	X	
The DRTS Control Tower shall support a battalion training cycle.			X	X	
The DRTS Control Tower shall support system restart due to loss of power, environmental control, or weather with no data loss.			X	X	
The DRTS Control Tower shall support both Ground and Aviation training events.			X		
The DRTS Control Tower shall support communications between the Control Tower and PUs within the range maneuver space. Repeaters shall be provided as required to relay communications.	X		X		
The DRTS Control Tower shall provide an operator workspace designed for comfort and safety based on a continuous 12-hour period of operation.	X				

#### 4.2.2.3. System Control (SYSCON)

<b>Requirement:</b>	<b>E</b>	<b>A</b>	<b>D</b>	<b>T</b>	<b>C</b>
The SYSCON WS shall provide the SW and HW necessary to support preparation of exercises.	X				
The SYSCON WS shall include the VSS Application.	X				
The SYSCON WS shall control and manage the DRTS SW.	X		X		
The SYSCON WS shall distribute, confirm distribution, and log Range Operations SW versions in use at the start of an exercise.	X		X		
The SYSCON WS shall load schema and table structures used for the database.	X		X		
The SYSCON WS shall initialize the default configuration database for an exercise.	X		X		

The SYSCON WS shall view and copy configuration data from previous exercises.	X		X		
The SYSCON WS shall log all operator and automatic actions for subsequent review (i.e. login name and SW accessed).	X		X		

#### 4.2.2.4. Player Administration

<b>Requirement:</b>	<b>E</b>	<b>A</b>	<b>D</b>	<b>T</b>	<b>C</b>
The SYSCON shall create Individual PU configuration data for each exercise.	X		X		
The SYSCON shall control and manage the PU Instrumentation, targets, and players.	X		X		
The SYSCON shall segment the configuration data generated for a PU specific to that PU.	X		X		
The SYSCON shall modify PU operating modes (e.g. sleep, power management, position update rates) by individual or logical groups of PU.	X		X		
The SYSCON shall administratively reset individual or logical groups of PU.					
The SYSCON shall administratively reload individual or logical groups of PU.					
The SYSCON shall administratively resurrect (target up) individual or logical groups of PU.					
The SYSCON shall transmit any command event to a PU.					
The SYSCON shall maintain a count of all player events by player.					
The SYSCON shall report missing events.					
The SYSCON shall initiate verification data for all PU components.					
The SYSCON shall log configuration data for all PU components.					
The SYSCON shall generate player configuration data.					
The SYSCON shall clear player configuration data.					
The SYSCON shall load configuration data via the Field Support Equipment (FSE) or transmitted via the RDCS to connected devices.					
The SYSCON shall generate Ground PU Configuration data.					
The SYSCON shall generate Aviation PU Configuration data.					

#### 4.3. Electromagnetic

<b>Requirement:</b>	<b>E</b>	<b>A</b>	<b>D</b>	<b>T</b>	<b>C</b>
The DRTS system shall be compatible with the electromagnetic and physical environment of the training areas and devices.	X				X

#### 4.3.1. Electromagnetic Environmental Effects (E3)

Requirement:	E	A	D	T	C
DRTS HW shall be electromagnetically compatible with all subsystems and equipment found at the training ranges.	X				X
DRTS HW shall operate in the electromagnetic environment (EME) described below without being a source of electromagnetic interference.	X				X

#### 4.3.2. Electromagnetic Compatibility (EMC)

Requirement:	E	A	D	T	C
The EMC shall not interfere with the system operational performance requirements.	X		X		

#### 4.3.3. Electromagnetic Radiation Hazards (EMRADHAZ)

Requirement:	E	A	D	T	C
The system equipment design shall protect personnel, fuels, and ordnance from hazardous effects of electromagnetic radiation.	X				X

#### 4.3.4. Non-Developmental Items (NDI) and Commercial Items

Requirement:	E	A	D	T	C
NDI and commercial items shall meet E3 requirements.	X				X
NDI and commercial items shall meet the RDCS operational performance and E3 requirements.	X				X
NDI and commercial items shall demonstrate the ability to detect maintainability, accessibility, and testability degradation which would affect the safe E3 operation at the installation site.	X				X

#### 4.4. Cybersecurity (CS)

Requirement:	E	A	D	T	C
DRTS components shall be assessed and authorized to operate at a Confidentiality (low), Integrity (low), and Availability (low) level of Low, Low, Low.	X				
System design shall incorporate security compliance reporting capabilities including the Continuous Monitoring Tool (CMT) and the Inventory Reconnaissance Tool (IRT) that allows local staff at deployed sites to collect information to be submitted to PM ST.	X				
All DRTS components shall have applicable Cybersecurity controls required by DODI 8510.01 and AR 25-2, and IAW the current DRTS SSP, Implementation Plan, and	X				

<p>supporting RMF documentation. These controls shall include, but are not limited to:</p> <ul style="list-style-type: none"> <li>a. All required Firewalls and Routers.</li> <li>b. All Cybersecurity or Cybersecurity-enabled components shall be on the National Information Assurance Partnership (NIAP) approved products list or must be in Common Criteria evaluation criteria. All WS shall utilize the most current approved version of Windows 10. All Windows servers shall utilize the most current approved version of Windows Server 2016 (or 2019).</li> <li>c. Encryption for all wireless connections transmitting sensitive data needs to utilize Federal Information Processing Standards (FIPS) 140-2 (for Unclassified) validated encryption modules as specified in RMF documentation.</li> <li>d. Current Government approved anti-virus SW installed on all servers and WSs in order to pass Cybersecurity test requirements at the time of integration.</li> <li>e. A backup and recovery capability and procedure shall be provided and validated per 8510.01.</li> <li>f. All components of the system shall be capable of being periodically updated for STIG compliance IAW the DRTS Information Assurance Vulnerability Assessment (IAVA) Management Plan detailed in the DRTS SSP.</li> <li>g. DOD Approved Ports, Protocols, and Services (PPS) shall be documented and maintained for all routed interfaces.</li> <li>h. All components shall be configured to meet the appropriate Security Technical Implementation Guides (STIGs) and System Security Requirements Guide (SRGs).</li> </ul>					
---	--	--	--	--	--

#### 4.5. Security

<b>Requirement:</b>	<b>E</b>	<b>A</b>	<b>D</b>	<b>T</b>	<b>C</b>
The system shall prevent inadvertent disclosure of any unclassified or sensitive information and provide safeguards	X		X		

to prevent unauthorized access to the system or information used by the system.				
The system shall limit all CS and CS-enabled Government-off-the-Shelf (GOTS) IT products to those products that have been evaluated by the National Security Agency (NSA) or IAW NSA approved processes.	X	X		
The system shall limit the acquisition of all CS and CS-enabled COTS IT products to those products that have been evaluated or validated through one of the following sources: the International Common Criteria (CC) for Information Security Technology Evaluation Mutual Recognition Arrangement, the NIAP Evaluation and Validation Program, or the FIPS validation program.	X	X		
The system shall ensure the technical system features ensure that recovery is done in a secure and verifiable manner.	X	X		
The system shall utilize DOD STIGs and SRGs as the primary source for security configuration or implementation guidance for the deployment of newly acquired CS and CS-enabled IT products that require use of the product's CS capabilities. If a DOD reference document is not available, the following are acceptable in descending order as available: (1) Commercially accepted practices (e.g., SANS); (2) Independent testing results (e.g., ICSA); or (3) Vendor literature.	X	X		
The system shall utilize NIST FIPS 140-2 validated cryptography (e.g., DOD PKI class 3 or 4 token) to implement encryption (e.g., AES, 3DES, DES, Skipjack), key exchange (e.g., FIPS 171), digital signature (e.g., DSA, RSA, ECDSA), and hash (e.g., SHA-1, SHA-256, SHA-384, SHA-512) where required and described in the current SSP and supporting documents.	X	X		
The system shall not utilize binary or machine executable public domain SW products and other SW products with limited or no warranty (i.e. freeware or shareware) in DOD information systems unless these products are necessary for mission accomplishment and there are no cost effective alternative IT solutions available. Such products shall be assessed for information assurance impacts, and approved for use by the Approving Official (AO). The assessment shall address the fact that such SW products are difficult or impossible to review, repair, or extend, given that the Government does not have access to the original source code and there is no owner who could make such repairs on behalf of the Government.	X	X		

The system shall comply with DOD requirements for ports, protocols, and services guidance where applicable.	X	X		
The system shall at a minimum, utilize medium-robustness COTS CS and CS-enabled products to protect sensitive information when the information may transit public networks or the system handling the information is accessible by individuals who are not authorized to access the information on the system.	X	X		
The system shall provide that system initialization, shutdown, and aborts ensure that the system remains in a secure state.	X	X		
The system shall require boundary defense mechanisms, to include firewalls and network Intrusion Detection Systems (IDS), be deployed at key points in the network, as required.	X	X		
The system shall be compliant with established DOD connection rules and approval procedures.	X	X		
The system shall include the following Audit records. 1) User ID. 2) Successful and unsuccessful attempts to access security files. 3) Date and time of the event. 4) Type of event. 5) Success or failure of event. 6) Successful and unsuccessful logons. 7) Denial of access resulting from excessive number of logon attempts. 8) Blocking or blacklisting a user ID, terminal or access port and the reason for the action. 9) Activities that might modify, bypass, or negate safeguards controlled by the system.	X	X		
The system shall provide tools for the aggregation and review of audit records and for report generation from audit records.	X	X		
The system shall apply all applicable DOD STIGs and SRGs.	X	X		
The system shall utilize good engineering practices with integration of COTS, GOTS, and custom developed solutions for incoming and outgoing files, such as parity checks and Cyclic Redundancy Checks.	X	X		
The system shall protect against unauthorized access, modification, and deletion.	X	X		
The system shall implement virus protection that includes a capability for automatic updates for all Servers, WSs and mobile computing devices (i.e. laptops) within the RMF authorization boundary.	X	X		
The system shall implement IAW DOD wireless policy, all wireless computing and networking capabilities from WSs,	X	X		

laptops, handheld computers, cellular phones, or other portable electronic devices.					
The system shall disable by changing factory defaults, settings, or configurations prior to issue to end users for all wireless computing capabilities internally embedded. Wireless computing and networking capabilities shall not be independently configured by end users.	X		X		
The system shall produce, control, and distribute using NIST approved key management technology and processes all symmetric keys as required by the DRTS SSP.	X		X		
The system shall produce, control, and distribute Asymmetric Keys using DOD PKI Class 3 certificates or pre-placed keying material as required by the DRTS SSP.	X		X		
The system shall accomplish identification and authentication using the DOD PKI Class 3 certificate and HW security token (when available) as required by the DRTS SSP.	X		X		

#### 4.5.1. System Access

<b>Requirement:</b>	<b>E</b>	<b>A</b>	<b>D</b>	<b>T</b>	<b>C</b>
The system security design shall incorporate the best security practices such as single sign-on, tokens, and other approaches as described in the DRTS SSP.	X				
Successive logon attempts shall be controlled using one or more of the following: 1) Access is denied after multiple unsuccessful logon attempts. 2) The number of access attempts in a given period is limited. 3) A time-delay control system is employed. If the system allows for multiple logon sessions for each user ID, the system provides a capability to control the number of logon sessions.	X		X		
All users shall be warned that they are entering a Government information system and provided with appropriate privacy/security notices to include statements informing them that they shall be subject to monitoring, recording, and auditing.	X		X		
DOD information system access is gained through the presentation of an individual identifier (e.g., a unique token or user login ID) and password. For systems utilizing a logon ID as the individual identifier, passwords shall be, at a minimum, a case sensitive 8-character mix of upper case letters, lower case letters, numbers, and special characters, including at least one of each (e.g., emPagd2!). Deployed/tactical	X		X		

systems with limited data input capabilities shall implement the password to the extent possible.					
System mechanisms shall be implemented to enforce automatic expiration of passwords and to prevent password reuse all factory set, default or standard-user IDs, and passwords shall be removed or changed.	X		X		
Authenticators shall be protected commensurate with the classification or sensitivity of the information accessed, which shall not be embedded in access scripts or stored on function keys. Passwords shall be encrypted both for storage and for transmission.	X		X		
Unless there is an overriding technical or operational problem, WS screen-lock functionality shall be associated with each WS, as required by the SSP. When activated, the screen-lock function places an unclassified pattern onto the entire screen of the WS, totally hiding what was previously visible on the screen. Such a capability shall be enabled either by explicit user action or a specified period of WS inactivity (e.g., 15 minutes). Once the WS screen-lock SW is activated, access to the WS shall require knowledge of a unique authenticator. A screen lock function shall not be considered a substitute for logging out (unless a mechanism actually logs out the user when the user idle time is exceeded).	X		X		

#### 4.5.2. Portable Electronic Devices (PEDS)

Requirement:	E	A	D	T	C
Wireless devices such as laptops and tablet connections shall be included in the updated DOD RMF Authority to Operate (ATO) package currently established, and signed by the AO. A thorough and comprehensive requirements validation, risk analysis, implementation, and migration plan shall be included within the required RMF package where required. Wireless connectivity shall not be authorized if the wired infrastructure that is to be extended is not authorized.	X				
Unused wireless computing capabilities internally embedded in interconnected DOD IT assets shall be disabled by changing factory defaults, settings or configurations prior to issue to end users.	X		X		
Wireless computing and networking capabilities shall not be independently configured by end users.	X		X		
Implement identification and authentication measures at both the device and network.	X		X		

For data at rest, PEDs shall use file encryption that is validated a meeting FIPS 140-2 requirements and as described in the DRTS SSP.	X		X		
All wireless devices including commercial unlicensed devices shall be coordinated with the Army Spectrum Management Office (ASMO) and the local Army Frequency Manager prior to purchase.	X		X		
All wireless devices procured with Army funds shall be certified for spectrum supportability through the Military Communications Electronics Board (MCEB) per DODD 5000.1 and AR 5-12.	X				
The use of personal e-mail (view and/or download) on a DRTS-controlled mobile device shall be prohibited.	X				
User owned personal data (i.e., music files, pictures, and movies) shall not be installed without authorization from the AO.	X		X		
Authorized users shall not connect to any social media web sites (i.e., Facebook, twitter).	X		X		
Personally-owned or contractor owned mobile devices shall be prohibited to transmit, receive, store, or process DOD information or connect to DOD networks.	X		X		
Devices that store or process data (camera, cellphone, two-way radios, etc.) shall not be authorized as DRTS-controlled mobile devices.	X		X		
The use of Geo-Location (GPS) aware applications to save or transmit the location of the device shall be prohibited.	X		X		
DRTS-controlled mobile devices shall not be connected to personally owned computers.	X				
DRTS-controlled mobile devices shall have services such as photo, video, voice recording, 802.11 (Wi-Fi), 802.15 (Bluetooth), and other wireless technologies disabled.	X				
Non-Enterprise activated DRTS-controlled mobile devices shall not be authorized to connect to DOD networks or to DOD computers connected to DOD networks.	X				

#### 4.6. System Safety

<b>Requirement:</b>	<b>E</b>	<b>A</b>	<b>D</b>	<b>T</b>	<b>C</b>
The contractor design approach shall ensure that the system, both COTS and GOTS modified/developed under this contract, is safe to operate and maintain and presents no uncontrolled safety, health, or environmental hazards to operators and maintainers throughout the life cycle of the system.	X				X

#### 4.6.1. Environmental Safety

<b>Requirement:</b>	<b>E</b>	<b>A</b>	<b>D</b>	<b>T</b>	<b>C</b>
The contractor shall ensure that the system is safe to operate and maintain.	X				X
The contractor shall present no uncontrolled safety, health, or environmental hazards to operators and maintainers throughout the life cycle of the system.	X				
The contractor shall comply with 29 CFR 1910, the National Fire Protection Association Codes, including hazards to users, operators, maintainers, and personnel adjacent to the system.	X				
The contractor shall provide fail-safe features for safety of personnel during installation, operation, maintenance, testing, support activities, and disposal.	X				
The contractor shall certify COTS equipment as meeting the requirements of a nationally accredited safety-testing laboratory for its intended use (i.e., UL, CSA), or host nation equivalent.	X				X
The contractor shall Mark training equipment that can be mistaken for tactical equipment as "FOR TRAINING USE ONLY"	X				

#### 4.6.2. Electrical Safety

<b>Requirement:</b>	<b>E</b>	<b>A</b>	<b>D</b>	<b>T</b>	<b>C</b>
Electrical circuitry and installation shall comply with the requirements of the National Electric Code (ANSI/NFPA 70-2002).	X				X
Electrical circuitry and installation shall be designed and installed with danger, caution, and warning signs. These signs shall be IAW ANSI Z535.3-98 and ANSI Z535.4-98 to warn user personnel of specific hazards.	X				X
Electrical circuitry and installation shall sufficiently separate batteries from electronic components to prevent damage from corrosion.	X				

#### 4.6.3. Hazardous Materials

<b>Requirement:</b>	<b>E</b>	<b>A</b>	<b>D</b>	<b>T</b>	<b>C</b>
The contractor shall use non-toxic/environmentally acceptable alternatives whenever possible from a cost effectiveness and operational point of view.	X				
The contractor shall not incorporate hazardous material, such as asbestos, glass fiber materials (as the outer surface or covering on cables, wire, or other items which may cause skin irritation to operating personnel); Halon or other Ozone-	X				

depleting substances; or Polyvinyl Chloride (PVC) materials within crew or personnel occupied compartments.					
The contractor shall install a caution note alerting maintenance personnel whenever maintenance procedures require access to glass fibers, such as insulation.	X				
The contractor shall preclude exposure of personnel or the environment to excessive levels of toxic, carcinogenic, or otherwise hazardous materials as defined by the Occupational Health and Safety Administration (OSHA), Environmental Protection Agency (EPA), and the Department of Transportation (DOT).	X				

#### 4.6.4. Personnel Safety

Requirement:	E	A	D	T	C
The design shall provide maximum safety to personnel and system equipment when installing, operating, adjusting, and maintaining the equipment.	X				
The design shall locate cables to preclude tripping hazards or damage to cables.	X				
The design shall conform to MIL-STD-1474 noise limits.	X				X
The design shall include the design, install, and label equipment and transit cases housing equipment to enable safe handling and lifting.	X				
The design shall conform to the single person lift limits shown in table located in section 3.6.4.	X				

#### 4.6.5. Mechanical Safety

Requirement:	E	A	D	T	C
The system design shall provide guards or safety devices on moving parts to prevent mechanical injury.	X				
The system design shall provide round edges and corners.	X				
The system design shall be free from burrs.	X				
The system design shall provide system center of gravity that is stable and easy to handle.	X				

#### 4.6.6. Antenna Safety

Requirement:	E	A	D	T	C
The Antenna Safety design shall have tip caps or other suitable design fixture to prevent puncture hazards to eyes, etc., where personnel are likely to be exposed to such hazards.	X				
The Antenna Safety design shall be coated with a dielectric material to insulate against at least 10,000 volts Root Mean Squared (RMS).	X				X

The Antenna Safety design shall provide adequate lightning protection.	X				
The Antenna Safety design shall Have the following design features for all fixed, semi-permanent, and mobile facilities that incorporate antenna tower/masts: 1) Antenna masts shall incorporate a ground stud to permit secure attachment of a ground strap/rod. 2) Lead-in wires require discharge units (lightning arrestors) on each conductor or enclosure in a continuous metallic shield that is effectively grounded; coaxial cable lead-in may be used as is if the outer shields are grounded at both ends.	X				
The Antenna Safety design shall protect personnel from accidental contact with antennas and other devices which carry RF voltage to burn or injure personnel. Microwave or RF radiation signs shall be permanently affixed to warn personnel of danger zones.	X				

#### 4.6.7. Battery Box Design Safety

Requirement:	E	A	D	T	C
Battery enclosures shall prevent electrolyte from being expelled in the event of battery leakage or venting.	X				
Battery enclosures shall provide battery box venting to minimize gas build-up.	X				
Battery enclosures shall not leak explosive or harmful battery gases into the equipment or any other source of ignition.	X				

#### 4.6.8. Electronic and System Protection

##### 4.6.8.1. Electrical Surge Protection

Requirement:	E	A	D	T	C
The system shall provide surge protection devices into the DRTS baselines.	X				
The surge protection shall be sized and appropriate for all of the equipment utilized.	X				

##### 4.6.8.2. Electrical Grounding

Requirement:	E	A	D	T	C
The DRTs system shall be grounded IAW the requirements defined in ANSI/NFPA 70-2001 requirements.	X				X

##### 4.6.8.3. Lightning Protection

Requirement:	E	A	D	T	C
The system shall provide lightning protection for the entire range and complex of facilities.	X				

The system shall employ an ion dispersal system in conjunction with any lightning arresters or suppressors you deem necessary.	X				
The lightning protection system shall be ballistic hardened (not damaged if repeatedly shot) and shall not create ricochets or fragments if shot.	X				X
The components of the lightning protection system shall comply with the applicable portions of ANSI/NFPA 780-1997.	X				X

#### 4.6.9. Environmental

<b>Requirement:</b>	<b>E</b>	<b>A</b>	<b>D</b>	<b>T</b>	<b>C</b>
The equipment shall withstand the representative environment and physical conditions of the DRTS ranges.	X		X		
Field equipment shall be designed to withstand exposure to the tactical environmental conditions to ensure survivability in the field.	X		X		
Environmental qualification shall include vibration, shock, temperature, rain, immersion, dust, salt, and fog in compliance to MIL-STD-810G.	X				X
These requirements shall be met by components located both inside and outside of Heating Ventilation and Air Conditioning (HVAC) controlled facilities.	X				X
Materials selected shall withstand, without deterioration, the effects of the environment in which the equipment is operated, stored, and transported.	X				X
The system shall be designed to withstand the representative environment for its fielded location(s).	X				X
The system shall be designed to withstand (without deterioration) environmental exposure during storage/shipping.	X				X
The equipment shall withstand temperatures in storage/shipping as cold as minus 51° F.	X				X
The equipment shall withstand temperatures in storage/shipping as hot as 145° F.	X				X
The system's components shall be designed/configured to withstand the typical stresses associated with handling/transportation/reconfiguration of the system.	X				
All environmental condition requirements shall be compliant with their corresponding section of MIL-STD-810G requirements.	X				X

#### 4.6.10. Indoor HVAC Controlled Facility Conditions

<b>Requirement:</b>	<b>E</b>	<b>A</b>	<b>D</b>	<b>T</b>	<b>C</b>
---------------------	----------	----------	----------	----------	----------

The equipment shall have a minimum of Ingress Protection of IP20.	X				X
Internally mounted equipment enclosures shall be NEMA 1 compliant.	X				X
The equipment shall be designed to be operated in a regulated internal climate controlled facility with an expected temperature range of 60°F to 80°F.	X				X
The equipment shall designed to be operated in a regulated internal climate controlled facility with an expected relative humidity range of 20% to 75% +/- 5%, not to exceed 80% (non-condensing).	X				X

#### 4.6.10.1. Indoor Non-HVAC Controlled Facility Conditions

<b>Requirement:</b>	<b>E</b>	<b>A</b>	<b>D</b>	<b>T</b>	<b>C</b>
The equipment shall withstand temperatures as cold as minus 40°F (-40°C).	X				X
The equipment shall withstand temperatures as hot as 122°F (50°C).	X				X
The equipment shall be capable of withstanding winds up to 35 mph.	X				X
The equipment shall endure a relative humidity range from 10 to 95 percent (non-condensing).	X				X
The equipment shall have a minimum of Ingress Protection of IP51.	X				X
Internally mounted equipment enclosures shall be NEMA 12 compliant.	X				X
All installed equipment and infrastructure shall prevent insect and animal intrusion.	X				X

#### 4.6.11. Outdoor Conditions

<b>Requirement:</b>	<b>E</b>	<b>A</b>	<b>D</b>	<b>T</b>	<b>C</b>
DRTS equipment installed outdoors without any protection from the environmental conditions shall meet the temperature: MIL-STD-810G Method 501.5 (A1) (Operating +49° C/ Non-operating: +71° C).	X				X
DRTS equipment installed outdoors without any protection from the environmental conditions shall meet the temperature: MIL-STD-810G Method 502.5 (C1) (Operating - 31° C/ Non-operating: -33° C).	X				X
DRTS equipment installed outdoors without any protection from the environmental conditions shall meet the Solar Radiation: MIL-STD-810G Method 505.5.	X				X
DRTS equipment installed outdoors without any protection from the environmental conditions shall withstand rain, sleet, snow and ice.	X				X

DRTS equipment installed outdoors without any protection from the environmental conditions shall meet the withstand wind gusts up to 70 mph.	X				X
DRTS equipment installed outdoors without any protection from the environmental conditions shall meet the endure a relative humidity range from 10 to 100 percent (condensing).	X				X
DRTS equipment installed outdoors without any protection from the environmental conditions shall meet minimum of Ingress Protection of IP55 (with exception of the exterior camera).	X				X
DRTS equipment installed outdoors without any protection from the environmental conditions shall meet Field Cameras shall have Ingress Protection of IP66.	X				X
DRTS equipment installed outdoors without any protection from the environmental conditions shall meet Externally mounted equipment enclosures shall be NEMA 13 complaint.	X				X
DRTS equipment installed outdoors without any protection from the environmental conditions shall Prevent insect and animal intrusion into installed equipment and infrastructure.	X				

#### 4.6.11.1. Shock

Requirement:	E	A	D	T	C
PU components and devices shall not be damaged when subjected to the specified shock spectrum of MIL-STD-810G, Method 516.6, Procedure I - Functional Shock.	X				X
PU components and devices shall not be damaged when subjected to the recommended drop test of Table 516.6-II and Procedure IV - Transit Drop (inside transit case).	X				X

#### 4.6.11.2. Vibration

Requirement:	E	A	D	T	C
PU shall not be damaged when tested IAW MIL-STD-810G, Method 514.6, Categories 1-5.	X				X

#### 4.6.11.3. Humidity

Requirement:	E	A	D	T	C
PU components and devices shall not be damaged during operations under relative humidity conditions IAW MIL-STD-810G Method 507.5.	X				X

#### 4.6.11.4. Rain and Immersion

Requirement:	E	A	D	T	C
PU components, devices, and all transit cases shall not be damaged when subjected to the following limits.	X				X

Those components and devices subjected to the immersion test shall not be subjected to the rain test.	X				X
PU shall be tested IAW MIL-STD-810G Method 506.5 (Rain) and 512.5 (Immersion).	X				X
The PU components mounted on the exterior of the vehicle shall show no evidence of water intrusion when immersed in water to a depth of 1 meter IAW MIL-STD-810G.	X				X

**4.6.11.5. Sand and Dust**

<b>Requirement:</b>	<b>E</b>	<b>A</b>	<b>D</b>	<b>T</b>	<b>C</b>
PU components and devices shall not be damaged when subjected to test IAW MIL-STD-810G, Method 510.5.	X				X

**4.6.11.6. Salt and Fog**

<b>Requirement:</b>	<b>E</b>	<b>A</b>	<b>D</b>	<b>T</b>	<b>C</b>
All exterior surfaces, including transit cases, shall be treated to resist corrosion or deterioration.	X				X
All exterior surfaces, including transit cases, shall as a minimum performance requirement, these surfaces shall exhibit no blistering, lifting of the coating system, and substrate corrosion after being subjected to a 5% sodium chloride atomized spray as described in MIL-STD-810G, Method 509.5.	X				X

**4.6.11.7. Explosive Atmosphere**

<b>Requirement:</b>	<b>E</b>	<b>A</b>	<b>D</b>	<b>T</b>	<b>C</b>
Capability of operation in flammable atmospheres shall be demonstrated by certification or design analysis IAW MIL-STD-810G, Method 511.5.	X				X

**4.6.11.8. Electromagnetic Environmental Effects (E3)**

<b>Requirement:</b>	<b>E</b>	<b>A</b>	<b>D</b>	<b>T</b>	<b>C</b>
The PU HW shall be electromagnetically compatible among all subsystems and equipment found at the training ranges and with electromagnetic environment external to the HW.	X				X
All equipment (NDI, COTS, modified COTS, new design) shall operate in the electromagnetic environment (EME) described below without being a source of electromagnetic interference or a victim of site/location generated electromagnetic emissions, whether radiated or conducted.	X				X
The DRTS site is expected to be a high electromagnetic noise environment for radiated energy.	X				X
The equipment site is an active military training range with an active airfield operation.	X				X

The equipment site contains electromagnetic effects from licensed/authorized RF emitters, lightning storms, power line transients, and electrostatic fields generated by human operators and maintainers.	X				X
---	---	--	--	--	---

**4.6.11.9. Electromagnetic Compatibility (EMC)**

<b>Requirement:</b>	<b>E</b>	<b>A</b>	<b>D</b>	<b>T</b>	<b>C</b>
DRTS equipment shall be electromagnetically compatible with itself and adjacent electrical, electromechanical, and electronic equipment at the installation site.	X		X		X
DRTS equipment shall be able to operate within the electromagnetic environment such that the PU operational performance requirements are met.	X		X		X
The PU components shall be subjected to the following EMC tests. No equipment supplied shall be exempted from these requirements.	X		X		X
PU Equipment operated on ground vehicles on the range shall not emit any intentional or unintentional signal that may cause live ammunition to be exploded.	X		X		X
Signal strength shall be measured for a representative number of PU at the antenna post and external housings when in a standby or receiving condition. The signal strength shall not be greater than -80 decibels from the peak operating power of the transmitter fundamental frequency.	X		X		X
PU shall be tested to the requirements of MIL-STD-461F, Ground Army, CE101-102, CS101, CS114, CS116, RE102, and RS103.	X		X		X

**4.6.11.10. Intra-System EMC**

<b>Requirement:</b>	<b>E</b>	<b>A</b>	<b>D</b>	<b>T</b>	<b>C</b>
The PU shall be electromagnetically compatible with itself such that system operational performance requirements can be met.	X				

**4.6.11.11. Inter-System EMC**

<b>Requirement:</b>	<b>E</b>	<b>A</b>	<b>D</b>	<b>T</b>	<b>C</b>
The PU shall be electromagnetically compatible with its defined EME such that the system operational performance requirements can be met.	X				X
The EME at the operational site is expected to average 200 V/m (RMS) in the frequency range of 10 KHz to 10 GHz.	X				X
Inter-system EMC covers compatibility with, but is not limited to, the operational site EME, adjacent equipment, and friendly emitters (CB, UHF, VHF, cellular, etc.).	X				X

**4.6.11.12. Non-Developmental items (NDI) and Commercial Items**

<b>Requirement:</b>	<b>E</b>	<b>A</b>	<b>D</b>	<b>T</b>	<b>C</b>
NDI and commercial items shall meet E3 requirements suitable for ensuring that the system operational performance requirements are met.	X				X

**4.6.11.13. Life Cycle, E3 Hardness**

<b>Requirement:</b>	<b>E</b>	<b>A</b>	<b>D</b>	<b>T</b>	<b>C</b>
The PU operational performance and E3 requirements shall be met throughout the rated life cycle of the equipment and shall include, but not be limited to, the following: maintenance, repair, surveillance, and corrosion control.	X				
The ability to detect maintainability, accessibility, and testability degradation shall be demonstrated for those areas, which would affect the safe E3 operation of the PU at the installation site.	X				

**4.6.11.14. Electromagnetic Radiation Hazards (EMRADHAZ)**

<b>Requirement:</b>	<b>E</b>	<b>A</b>	<b>D</b>	<b>T</b>	<b>C</b>
The equipment design shall protect personnel, fuels, and ordnance from hazardous effects of electromagnetic radiation.	X				X

**4.7. Logistics**

<b>Requirement:</b>	<b>E</b>	<b>A</b>	<b>D</b>	<b>T</b>	<b>C</b>
An integrated logistics process shall be used to develop the best support requirements for the DRTS.	X				
The logistics support approach shall be implemented to maximize the cost effective life cycle operations and maintenance support.	X				

**4.7.1. Maintenance Concept**

<b>Requirement:</b>	<b>E</b>	<b>A</b>	<b>D</b>	<b>T</b>	<b>C</b>
Life Cycle Contractor Support (LCCS) shall be used to support the DRTS.	X				
Off-site support shall reflect Depot level activities	X				
The maintenance concept for the DRTS components and sub-components shall consist of the levels of maintenance described below.	X				

**4.7.1.1. Levels of Maintenance**

<b>Requirement:</b>	<b>E</b>	<b>A</b>	<b>D</b>	<b>T</b>	<b>C</b>
---------------------	----------	----------	----------	----------	----------

The levels of maintenance for the DRTS shall consist of 2 levels, Organizational (On-line and Off-line) and Depot.	X				
COTS, Original Equipment Manufacturer (OEM) and Trainer Peculiar Equipment (TPE) shall be included in each level of maintenance.	X				
Field On-line Maintenance - On-line maintenance activities shall verify that the training and range equipment is ready for training by performing appropriate tests and inspections.	X				
Field On-line Maintenance - On-line maintenance activities shall Isolate training equipment malfunctions to faulty parts or assemblies using standard test equipment, test procedures, computer based diagnostics, maintenance documentation, inspection and by substitution when an ambiguity group is identifiable.	X				
Field On-line Maintenance - On-line maintenance activities shall Remove and replace faulty parts in a manner that minimizes training and range equipment downtime followed by verification of the repair using the training equipment as a test bed. Verify that the training equipment returns to its operable state.	X				
Field On-line Maintenance - On-line maintenance activities shall Perform scheduled maintenance during non-training hours, as required.	X				
Field On-line Maintenance - On-line maintenance activities shall Isolate and document SW related failures.	X				
Field Off-line Maintenance shall Repair of those failed assemblies that can be repaired using only standard test equipment, commercially available maintenance data (usually OEM developed), and off-the-shelf replacement parts.	X				
Field Off-line Maintenance shall Perform fault isolation and repair of failed repairable assemblies on-site through the use of test equipment and maintenance documentation.	X				
Sustainment level maintenance shall consist of commercial repair/overhaul of failed assemblies that are beyond the repair capability of Field maintenance.	X				

**4.7.1.2. Qualitative Maintainability**

<b>Requirement:</b>	<b>E</b>	<b>A</b>	<b>D</b>	<b>T</b>	<b>C</b>
---------------------	----------	----------	----------	----------	----------

General maintainability characteristics of the equipment added or modified as a result of required DRTS modifications or upgrades shall be as specified in the following paragraph.	X				
---	---	--	--	--	--

#### 4.7.1.3. Special tools

Requirement:	E	A	D	T	C
There shall be no need to use special tools for equipment maintenance unless common tools are inadequate.	X				
Special tools shall be retained in holders provided inside of the equipment near where the tools are normally used.	X				

#### 4.7.1.4. Built-In Test (BIT)

Requirement:	E	A	D	T	C
The training equipment design shall include built-in, non-continuous, fault detection and isolation test to detect performance degradation and failures for all equipment (Commercial Items, Government Furnished Property (GFP), Contractor Acquired Property (CAP), TPE, etc.)	X				
The BIT shall be manually or digitally invoked and shall furnish the means of determining the functional status of the DRTS and subsystems down to the individual LRU.	X				

#### 4.7.1.5. Accessibility

Requirement:	E	A	D	T	C
The DRTS accessibility shall provide the means to access internal parts, terminals, and wiring, for adjustments, required circuit checking, and the removal and replacement of maintenance parts.	X				
Accessibility for testing shall not apply to parts located in non-repairable assemblies.	X				
For routine servicing and maintenance, unsoldering of wires, wire harnesses, parts, or subassemblies shall not be required in order to gain access to terminals, soldered connections, mounting screws, and the like.	X				

#### 4.7.1.6. Parts

Requirement:	E	A	D	T	C
Replaceable parts shall be readily removable.	X		X		
Replaceable parts shall not be permanently mounted by means such as rivets, spot welding, or hard curing compounds	X				
No unsoldering of connections shall be necessary in order to remove front panels or sub-chassis for maintenance purposes.	X				

#### 4.7.1.7. Assemblies

<b>Requirement:</b>	<b>E</b>	<b>A</b>	<b>D</b>	<b>T</b>	<b>C</b>
All parts shall be readily accessible for maintenance.	X				
Locking devices shall be provided to lock the chassis in the servicing position and Tracks, rollers, hinges, pivots, or a combination thereof shall be installed for providing accessibility to units, assemblies, subassemblies, and parts.	X				
Each major assembly, subassembly, and unit shall permit access to its interior components and parts for maintenance	X				
It shall not be necessary to displace or remove wires, cables, subassemblies, or assemblies in order to gain access to mounting screws, test points, adjustment points, lubricating points, and the like.	X				
Where visual inspection is necessary and open access is not feasible, transparent access panels shall be used.	X				
The placement of parts shall provide space for the use of test probes and maintenance tools.	X				
Assemblies subject to replacement or service shall not be permanently fastened.	X				

#### 4.7.1.8. Modular assemblies

<b>Requirement:</b>	<b>E</b>	<b>A</b>	<b>D</b>	<b>T</b>	<b>C</b>
Modular assemblies such as circuit boards shall be equipped with connectors so that they may be removed without de-soldering.	X				
All modular assemblies shall be designed so that they can be inserted into the equipment in 1 position only.	X				
All sockets within each assembly shall be oriented in the same direction and positioned so that they are visible.	X				
Modular circuits shall be grouped in functional units.	X				

#### 4.8. Facilities

<b>Requirement:</b>	<b>E</b>	<b>A</b>	<b>D</b>	<b>T</b>	<b>C</b>
The DRTS shall operate within the Government-Furnished Facilities (GFF) or Range Tower identified in the contract.	X		X		
The DRTS design characteristics shall minimize the need for modifications to the GFF.	X		X		
Any DRTS design requiring a change to GFF shall be presented at the first design review for Government concurrence/approval.	X				
All connections between the training system equipment and the GFF utility and grounding points shall be provided in accordance with applicable codes and regulations.	X				
The equipment shall be designed to utilize the facility as it currently exists.	X				

The equipment design shall not require any architectural or structural modifications.	X				
---	---	--	--	--	--

#### 4.9. Reliability

Requirement:	E	A	D	T	C
The DRTS System shall provide a mission operating cycle of 20 days	X				
The DRTS System shall provide a minimum acceptable Mean Time Between Essential Function Failure (MTBEFF) for the PU of 1,000 hours. This requirement excludes Government Furnished Property (GFP).	X				X
The DRTS System shall satisfy the reliability requirements test shall be conducted in accordance with MIL-HDBK-781, Test Plan XIV (lower test MTBF limit), and the approved reliability test procedures.	X				X
The DRTS System sample size for the qualification test shall not be less than 5 units and not greater than 20 units.	X				

#### 4.10. Maintainability

Requirement:	E	A	D	T	C
The DRTS System shall provide a Mean Corrective Maintenance Down Time (MCT) of 30 minutes or less for the performance of on-equipment maintenance.	X			X	
The DRTS System shall have no special tools required for the maintenance of the system.	X				

#### 4.11. Human Engineering

Requirement:	E	A	D	T	C
The DRTS System shall provide a design to enhance operational efficiency, interaction, and realism; while meeting all applicable safety, health, and human factor requirements for training devices.	X				
The DRTS System shall comprehensively integrate human characteristics into system definition, design, development and evaluation to optimize performance of human in the loop.	X				
The DRTS System shall avoid an increase in required manpower, while easing physical tasks, time required for maintenance as well as minimizing the chance of operator/maintainer error or accident.	X				
The DRTS System shall be consistent with Joint Technical Architecture Human-Computer Interface Standards.	X				
The DRTS System shall allow for Operators and rotational unit users to operate and use PU safely and effectively.	X				
The DRTS System shall provide SW with a common man-machine interactive display and control interface for all SW	X				

functions in order to maximize the efficiency of the operator's use.					
The DRTS System shall meet all applicable industry and Government Human Factors Engineering (HFE) requirements.	X				
The DRTS System shall provide a design and functionality of the PU training system IAW the following sections of MIL-STD-1472: Control 5.1 (Control/display integration); 5.2 (Visual displays); 5.3 (Audio displays); 5.4 (Controls); 5.5 (Labeling); 5.6 (Anthropometry); 5.9 (Design for maintainer); 5.11.1 Portability of Load Carrying; 5.13 (Hazards and safety); 5.15 (User-computer interface). Not create any new operator military occupational specialty (MOS).	X				
The DRTS System shall not create any new operator military occupational specialty (MOS).	X				
The DRTS System shall not create additional skills and other personnel qualitative increases.	X				
The DRTS System shall allow for operational tasks to be performed by the Soldiers, exercise controllers and analysts who may be active duty, Department of the Army Civilian (DAC), or contractor personnel.	X				

## 5. Abbreviations and Acronyms

The following list of abbreviations and acronyms are utilized in the DRTS performance Specification.

ABBREVIATION	TERM
AAR	After Action Review
ADRG	Arc Digitized Raster Graphics
ADT	Aviation Data Translators
AGI	Air/Ground Integration
AGR	Aerial Gunnery Range
ALRMS	Alarm Status
AMPS	Aviation Mission Planning System
ANSI	American National Standards Institute
AO	Approving Official
ATO	Authority to Operate
AWSS	Aerial Weapons Scoring System
BAX	Battle Area Complex
BES	Battlefield Effects Simulators
BIT	Built-In Test
BFT	Blue Force Tracker
BFV	Bradley Fighting Vehicle

ABBREVIATION	TERM
BMUE	Bustle Modular Unit Equipment
BTS	Boot-up Status
CA	Casualty Assessment
CAP	Contractor Acquired Property
CATS	Combined Arms Training Strategy
CC	Common Criteria
CEWS	Crew Evaluator Workstations
CGM	Computer Graphics Metafile
CGS	Common Ground Station
CLF	Convoy Live Fire
CM	Configuration Management
CMT	Continuous Monitoring Tool
COTS	Commercial-off-the-Shelf
CS	Cybersecurity
CSC	Computer Software Component
CSS	Control Station Subsystem
CSU	Computer Software Unit
CSCI	Computer Software Configuration Item
CT	Control Tower (i.e., Range Operations Center)
CTIA	Common Training Instrumentation Architecture
DAGIR	Digital Air/Ground Integration Range
DMPRC	Digital Multi-Purpose Range Complex
DMPTR	Digital Multi-Purpose Training Range
DOD	Department of Defense
DOT	Department of Transportation
DRTS	Digital Range Training System
E3	Electromagnetic Environmental Effects
EMC	Electromagnetic Compatible
EME	Electromagnetic Environment
EMRADHAZ	Electromagnetic Radiation Hazards
EMS	Element Management System
EPA	Environmental Protection Agency
EXCON	Exercise Control
FARP	Forward Area Refueling Point
FASIT	Future Army System of Integrated Targets
FC	Field Camera
FIPS	Federal Information Processing Standards
FLIR	Forward Looking Infrared Radar
FOT	Force-on-Target
FOV	Field of View
FSE	Field Support Equipment
GFE	Government Furnished Equipment

ABBREVIATION	TERM
GFF	Government Furnished Facilities
GFI	Government Furnished Information
GFP	Government Furnished Property
GMT	Greenwich Mean Time
GOTS	Government-off-the-Shelf
GPS	Global Positioning System
GPSE	Gunner's Primary Sight Extension
GPS-LoS	Gunner's Primary Sight-Line of Sight
GS	General Support
GUI	Graphical User Interface
HW	Hardware
IAVA	Information Assurance Vulnerability Assessment
IAW	In Accordance With
IBAS	Improved Bradley Acquisition Subsystem
ICD	Interface Control Document
IDD	Interface Design Document
IDS	Intrusion Detection Systems
IEC	International Electro-technical Commission
IPUR	Integrated Player Unit Recorder
IR	Instrumented Ranges
IRT	Inventory Reconnaissance Tool
IS	Interfaces Status
IT	Information Technology
LCCS	Life Cycle Contractor Support
LFX	Live Fire Exercise
LRU	Line Replaceable Units
LT2	Live Training Transformation
MCT	Mean Corrective Maintenance Down Time
MCEB	Military Communications Electronic Board
MFVP	Multi-Function Vehicle Port
MGRS	Military Grid References System
MOS	Military Occupational Specialty
MPEG	Moving Pictures Experts Group
MTBEFF	Mean Time Between Essential Functional Failure
NC	Network Component
NDI	Non-Developmental Item
NGIC	National Ground Intelligence Center
NIAP	National Information Assurance Partnership
NSA	National Security Agency
OEM	Original Equipment Manufacturer
OSHA	Occupational Health and Safety Administration
OS	Operating System

ABBREVIATION	TERM
PEDS	Portable Electronic Devices
PPS	Ports, Protocols, and Services
PU	Player Unit
PTT	Push-To-Talk
PWS	Presentation Workstation
RDCS	Range Digital Communication System
RF	Radio Frequency
RMF	Risk Management Framework
RMS	Root Mean Squared
RSO	Range Safety Officer
RTP	Real Time Processes
RTU	Radio/Telephone Interface Unit
SAW	Situational Awareness Window
SCSI	Small Computer Systems Interface
SDSD	System Diagnostic Status Display Capability
SDT	Scenario Development Tool
SINGGARS	Single-Channel Ground-Air Radio System
SNMP	Simple Network Management Protocol
SOA	Service Oriented Architecture
SRG	Security Requirements Guide
SSP	System Security Plan
STIG	Security Technical Implementation Guide
SVRS	Servers Status
SW	Software
SWS	SW Status
SYSCON	System Control
TASS	Tactical Automated Security Systems
TC	Training Circular
TCU	Transceiver & Control Units
THP	Take-Home Package
TOMC	Technical Operations and Maintenance Control
TPE	Trainer Peculiar Equipment
TS	Targetry System
TSV	Thru-Site-Video
UAS	Unmanned Aerial System
UPS	Uninterruptible Power Supply
USB	Universal Serial Bus
UTC	Coordinated Universal Time
UTM	Universal Transverse Mercator
VCI	Voice Communications Interface
VSS	Video System Suite
WGS	World Geodetic System

ABBREVIATION	TERM
WLAN	Wireless Local Area Network
WS	Workstation

DRAFT