

Laser Chiller LC 340.01-A.3.5/6

IPG Photonics Corporation
50 Old Webster Road
Oxford, MA 01540 USA

Telephone: +1-508-373-1157

Email: support@ipgphotonics.com
Internet: www.ipgphotonics.com



Notices

© IPG Photonics Corporation. All rights reserved. You may not copy, reproduce, transmit, store in a retrieval system or adapt this publication, in any form, in any media or by any means, without the prior written permission of IPG Photonics Corporation (IPG), except as allowed under applicable copyright laws. Permitted copies shall bear the same copyright and proprietary notices which were contained on the original version.

All information contained in this document is subject to change and revision without notice. IPG believes that the information provided is accurate and reliable, however IPG makes no warranty or representation, express or implied regarding this document, including without limitation the implied warranties of merchantability or fitness for a particular purpose. Further, IPG does not assume responsibility for use of the information contained in this document or for any infringement of patents or other rights of third parties that may result from its use. IPG shall not be liable for errors contained in this document or for incidental, consequential, indirect or special damages in connection with the furnishing, performance or use of this material.

IPG grants no license, directly or indirectly under, any patent or other intellectual property rights from use of the information provided herein.

IPG, IPG Photonics and the IPG Logo are registered trademarks of IPG Photonics Corporation. We have identified words that we consider as trademarks. Neither the presence nor absence of trademark identifications affects the legal status of any trademarks.

Preface

Please take time to read and understand this Service Manual and familiarize yourself with the operating and maintenance instructions that we have compiled for you before you use the product. We recommend that the operator read Chapter 2, Safety Instructions, prior to operating the product.

This Service Manual should stay with the product to provide you and all future users and owners of the product with important operating, safety and other information.

US Export Control Compliance

IPG's policy and business code is to comply strictly with the U.S. export control laws.

Export and re-export of lasers manufactured by IPG are subject to the US Export Administration Regulations administered by the Department of Commerce, Bureau of Industry and Security.

The applicable restrictions vary depending on the specific product involved, intended application, the product destination and the intended user. In some cases, an individual validated export license is required from the U S Department of Commerce prior to resale or re-export of certain products. Please contact IPG, if you are uncertain about the obligations imposed by US law.

Current revision status: April 4, 2019

IPG Serial numbers:

Laser: _____

Chiller: _____

Operator details:

Inventory number: _____

Installation location: _____

Keep for future use

Index of contents:

1	GENERAL INFORMATION	4
2	SAFETY AND ACCIDENT PREVENTION	5
3	TECHNICAL DATA	7
4	TRANSPORT	12
5	FIRST START-UP OF THE CHILLER	15
6	PIPING AND INSTRUMENTS DIAGRAM	21
7	ADJUSTING AND MAINTENANCE WORK	28
8	INTERRUPTION OF OPERATION	38
9	ELECTRICAL DRAWING	53

1 GENERAL INFORMATION

1.1 Introduction

Please take the time to read and understand the information presented in this manual. By carefully reading the manual before starting up the chiller you will be better able to ensure proper and safe operation of this equipment.

In case of problems, please disconnect the chiller and contact our service department.

2 SAFETY AND ACCIDENT PREVENTION

2.1 General Instructions

This manual contains basic instructions that must be observed during initial operation of the unit, as well as during regular operation and maintenance. This manual must therefore be read by the installer and the operating personnel in charge prior to initial operation. It must also be permanently available at the location where the unit is being used.

All safety instructions including the instructions mentioned in other sections of this manual must be observed. Non-observance of the safety instructions may cause injuries, destroy the environment or damage the unit.

2.2 Personnel qualification and training

Operating, maintenance, inspection and installation personnel must be properly qualified for their work. Scope of responsibility and supervision of personnel must be defined and periodically reviewed by the facilities' management.

2.3 Safe performance of work

The safety instructions mentioned in these operating instructions, including the existing national regulations on accident prevention as well as any specific plant safety instructions must be observed.

Protective guards that have been installed to prevent contact with moving parts may not be removed when the unit is being operated. Lock-out / tag-out procedures must be followed during maintenance and repair of this equipment. (For detailed information, refer to your facilities' procedures and the regulations of local authorities.)

2.4 Safety instructions on maintenance, inspection and installation work

As a basic rule, none of the cleaning or maintenance tasks may be performed until the unit has come to a complete stop. The shutdown procedure described in the operating instructions must be observed. As soon as this work has been completed, all the safety devices and protective equipment must be mounted or installed according to their proper function.

2.5 Arbitrary modification and production of spare parts





The unit may not be converted or modified without expressed permission and agreement from the manufacturer. Only original spare parts and accessories accepted by the manufacturer are authorized for replacement and repair. The use of any other parts may cancel the manufacturer's liability for subsequent damages.

2.6 Non-Permissible operating methods

The operational safety of the delivered unit is guaranteed only if the unit is properly used as intended in accordance with section 7.1. The limit values included in the technical data (see item 2) must not be exceeded.

2.7 Safety symbols

In this user manual you will find following safety symbols:

 <p>DANGER</p>	<p>DANGER:</p> <p>Refers to a potential personal hazard. It requires a procedure that, if not correctly followed, may result in death or extremely severe injury to you and / or others. Do not proceed beyond a DANGER sign until you completely understand and meet the required conditions.</p>
 <p>WARNING</p>	<p>WARNING:</p> <p>Refers to a potential personal hazard. It requires a procedure that, if not correctly followed, may result in bodily harm to you and/or others. Do not proceed beyond the WARNING sign until you completely understand and meet the required conditions.</p>
 <p>CAUTION</p>	<p>CAUTION:</p> <p>Refers to a potential personal hazard, with lower risk. It requires a procedure that, if not correctly followed, may result in bodily harm to you and/or others. Do not proceed beyond the CAUTION sign until you completely understand and meet the required conditions.</p>
	<p>ADVICE:</p> <p>Refers to a specific instruction for handling, operation, or maintenance of the chiller.</p>

Technical data

3 Technical Data

3.1 General data

Type:	LC 340.01-A.3.5/6
Electric drawing:	P35-001340
Mechanical drawing:	P20-000165

3.2 Refrigerant circuit

Type of refrigerant:	R407C
Refrigerant filling:	kg 7.0
Maximum pressure:	bar 28

3.3 Dimension and weight water module

Footprint:

Depth:	mm	1093
Width:	mm	815
Height:	mm	1952

Additional depth electrical cabinet:

Depth:	mm	211
Width:	mm	500

Weight:

Without water filling:	kg	480
With water filling:	kg	600

3.4 Operating voltage 460 V / 3 Phase / 60 Hz

Design point:

Cooling capacity:	kW	38.8
Heat load to the air:	kW	52.2
Air inlet temperature:	°C	+ 33
Air flow:	m ³ /h	12000

Operating limits:

Max. air inlet temperature:	°C	+ 40
Min. air inlet temperature:	°C	+ 10
Min. water flow evaporator:	l/min	44
Max. storage temperature:	°C	+ 64
Min. storage temperature:	°C	- 40 (without water)

Electrical data:

Power consumption @ design point:	kW	21.0 (without tank heaters)
Max. power consumption:	kW	24.9
Connecting voltage:		460 V / 3 Ph / PE
Voltage tolerance:	%	+/- 10
Frequency:	Hz	60
Control voltage:	VDC	24

Technical data

Tap water circuit:

Cooling capacity:	kW	37.8
Cooling water outlet temperature:	°C	+ 21.0
Cooling water inlet temperature:	°C	+ 28.6
Stability of cooling water temperature:	°C	+/- 1.0
Water content:	Litre	120
Water flow:	l/min	70
Water pressure:	bar	4.5

DI-Water circuit:

Cooling capacity:	kW	1
Cooling water outlet temperature:	°C	30.0
Stability of cooling water temperature:	°C	+/- 0.5
Water content:	Litre	25
Water flow:	l/min	30
Water pressure:	bar	4.0

3.5 Operating voltage 400 V / 3 Phase / 50 Hz

Design point:

Cooling capacity:	kW	34
Heat load to the air:	kW	42.5
Air inlet temperature:	°C	+ 33
Air flow:	m ³ /h	10000

Operating limits:

Max. air inlet temperature:	°C	+ 40
Min. air inlet temperature:	°C	+ 10
Min. water flow evaporator:	l/min	35
Max. storage temperature:	°C	+ 64
Min. storage temperature:	°C	- 40 (without water filling)

Electrical data:

Power consumption @ design point:	kW	17.9 (without tank heaters)
Max. power consumption:	kW	21.1
Connecting voltage:		400 V / 3 Ph / PE
Voltage tolerance:	%	+/- 10
Frequency:	Hz	50
Control voltage:	VDC	24

Tap water circuit:

Cooling capacity:	kW	33
Cooling water outlet temperature:	°C	+ 21.0
Cooling water inlet temperature:	°C	+ 28.6
Stability of cooling water temperature:	°C	+/- 1.0
Water content:	Litre	120
Water flow:	l/min	70
Water pressure:	bar	3.0

Technical data

DI-Water circuit:

Cooling capacity:	kW	1
Cooling water outlet temperature:	°C	30.0
Stability of cooling water temperature:	°C	+/- 0.5
Water content:	Litre	25
Water flow:	l/min	21
Water pressure:	bar	3.0

Technical data

3.6 Pump charts

3.6.1 Laser, 60 Hz – Dual Pumps

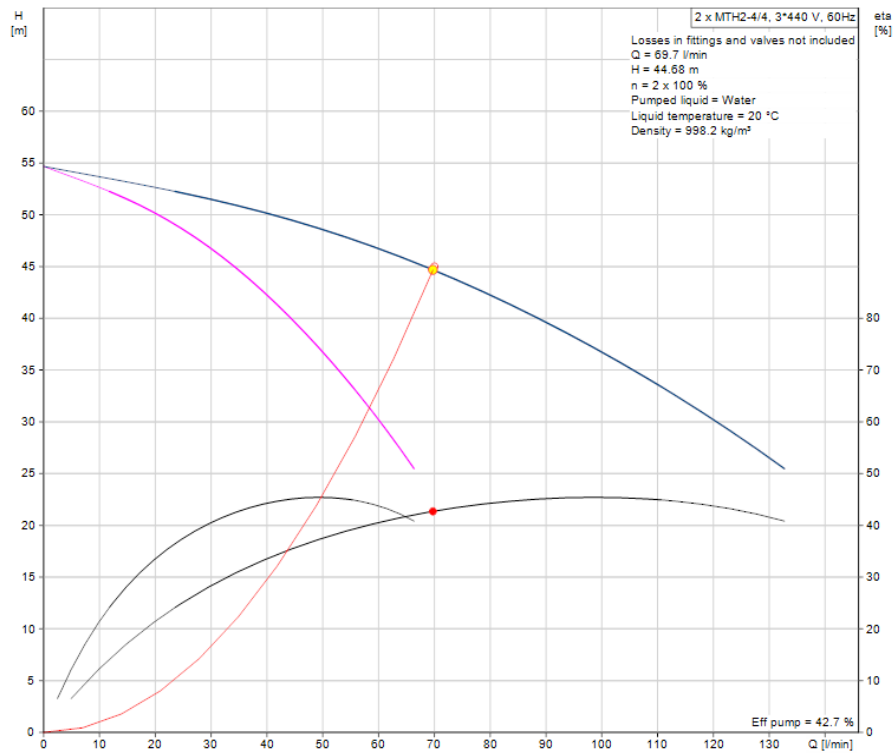

3.6.2 Optic, 60 Hz

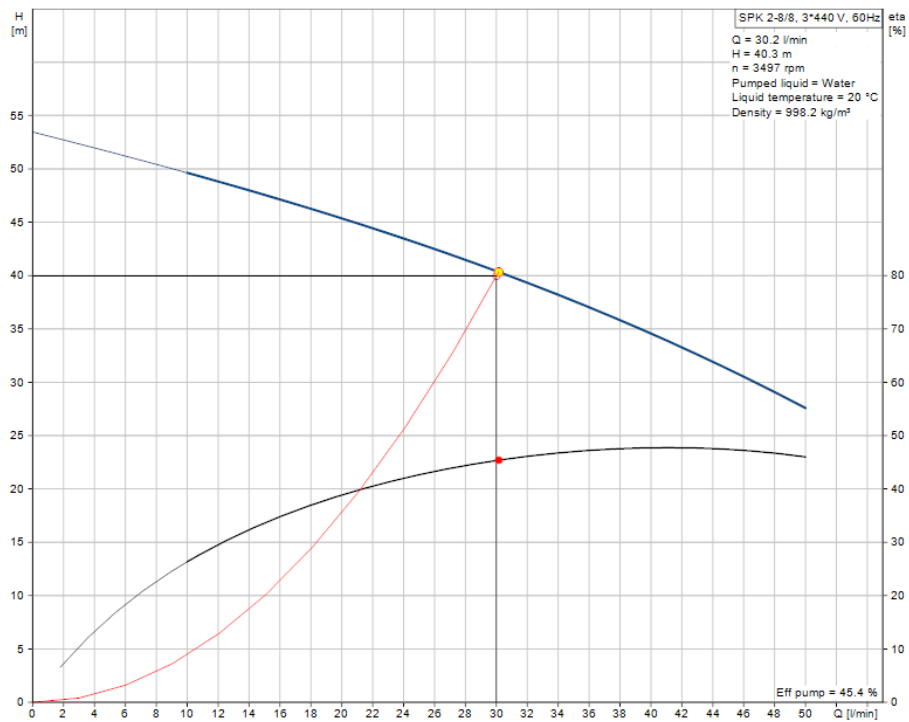

Technical data

3.6.3 Laser, 50 Hz – Dual Pumps

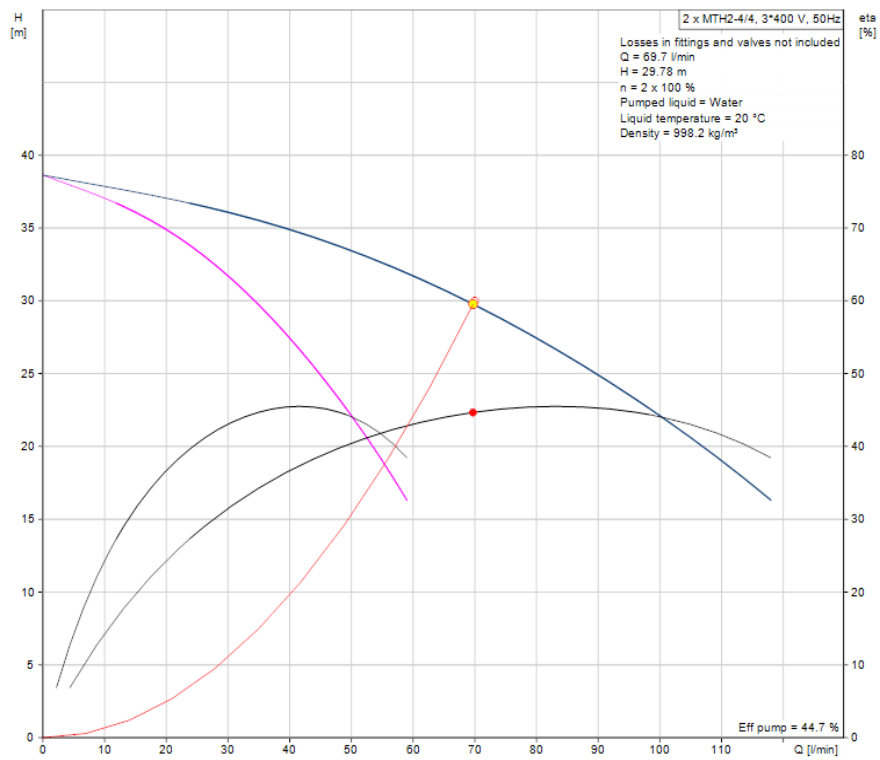

3.6.4 Optic, 50 Hz

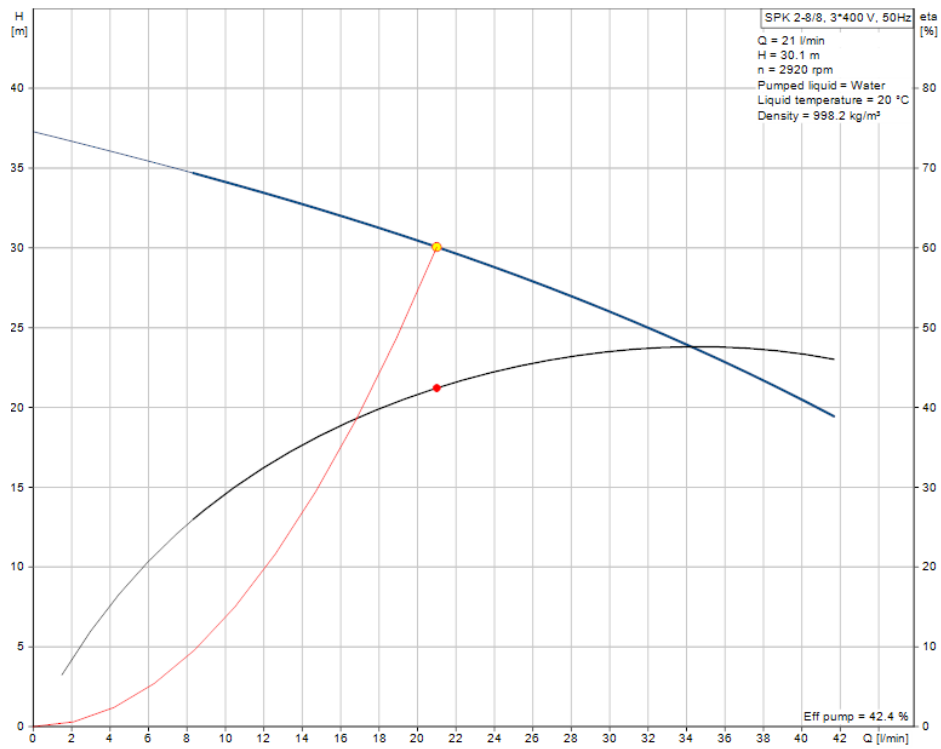

4 TRANSPORT

If the chiller has to be moved to another location, the water inside the tanks must be drained. Take care during transportation, not to damage the chiller. If damage occurs, the chiller must be checked by an expert before restarting.



WARNING

WARNING:

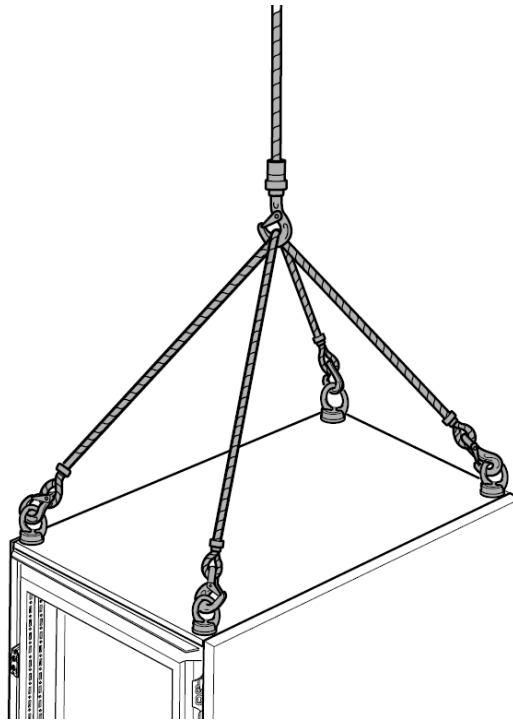

Cable angle if lifting by crane: $< 60^\circ$







WARNING

WARNING:

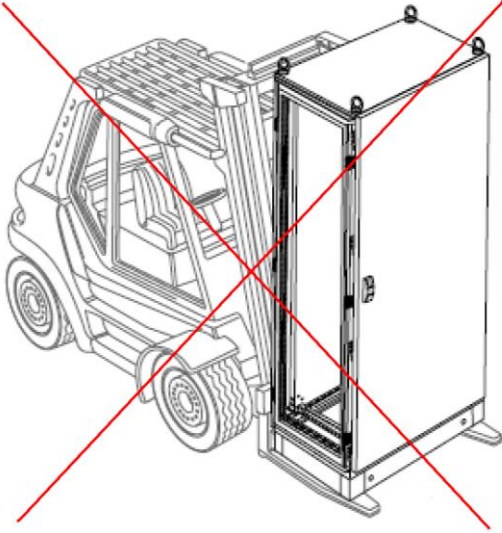

 **Cable angle**

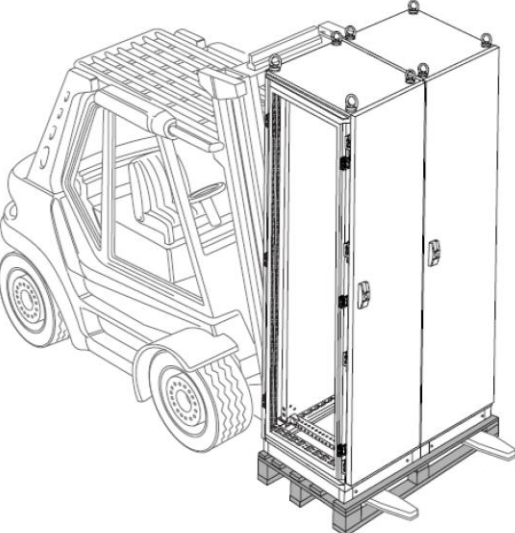
	<p>ADVICE:</p>  <p>Add Eyebolts for lifting by crane in accordance with DIN 580.</p>
 <p>WARNING</p>	<p>WARNING:</p> 
	<p>ADVICE:</p> 

**ADVICE:**

If the chiller has to be moved to another location, the water inside the tanks must be drained.

If the route of transport is not frost-protected, the complete unit has to be drained. We strongly recommend disassembling the DI-Cartridge as completely draining of the cartridge is difficult. To start up the unit again, please use a fresh DI-Cartridge.

5 FIRST START-UP OF THE CHILLER

5.1 Place of installation

The chiller has to be installed on a flat hard surface where the stability under load is guaranteed. It's not allowed to install the chiller at locations with risk of freezing (ambient temperatures lower than 4°C)

 DANGER	<p>DANGER:</p> <p>Refrigerant units have to be installed in a manner such that there is no danger of damage due to in-plant traffic or transportation.</p>
--	---

5.2 Wall distance

To ensure proper heat dissipation, the minimum distance from the air inlet grids to the wall must be at least 800 mm.



5.3 Maintenance room

The free room above the chiller should be at least 1200 mm. Make sure that the outgoing warm air cannot be re-circulated to the air inlet of the chiller.

5.4 Installation room according EN 378-1 tab. C.1

EN 378-1 defines the practical critical value for a refrigerant as the maximum concentration, where direct actions to escape people out of the room are not necessary.

According EN378-1 tab. C.1 the practical critical value for R407C is 0,31 kg/m³. The minimum room size for areas with no entrance limitation is 20 m³.

 DANGER	<p>DANGER:</p> <p>In case of damaging the refrigerant circuit, high pressured gas can escape abruptly. The escaping gas will immediately cool down to -40°C. The cold gas can cause frostbite to skin. The refrigerant gas is non-toxic.</p>
 DANGER	<p>In case of a leakage please take care of following points:</p> <ul style="list-style-type: none"> - Please stop smoking in case of refrigerant gas leak. The gas will pyrolyze in the presence of a lit cigarette and change into a toxic acid that can cause a chemical burn - Do not touch any escaping gas - Please take care for a well air ventilation inside the room - Turn the disconnecter in OFF Position - Inform an HVAC Technician

5.5 Connecting the chiller with the laser

The water connections are labelled as follows :

- Main Supply (Outlet chiller / Inlet laser)
- Optic Supply (Outlet chiller / Inlet optic)
- Main Return (Inlet chiller / Outlet laser)
- Optic Return (Inlet Chiller / Outlet optic)

Please use the provided hose pipes for connecting the laser with the chiller.

ADVICE:

It's forbidden to use following materials for water piping:

- mild steel
- galvanized steel

We recommend to use following materials for water piping:

- Cooling circuit Laser: Copper or stainless steel
- Cooling circuit Optics: Stainless steel (1.4301)

Water pipes should be design as follows:

- Cooling circuit Laser: 8 m³/h @ $\Delta p_{max} = 0,5$ bar
- Cooling circuit Optics: 2 m³/h @ $\Delta p_{max} = 0,5$ bar

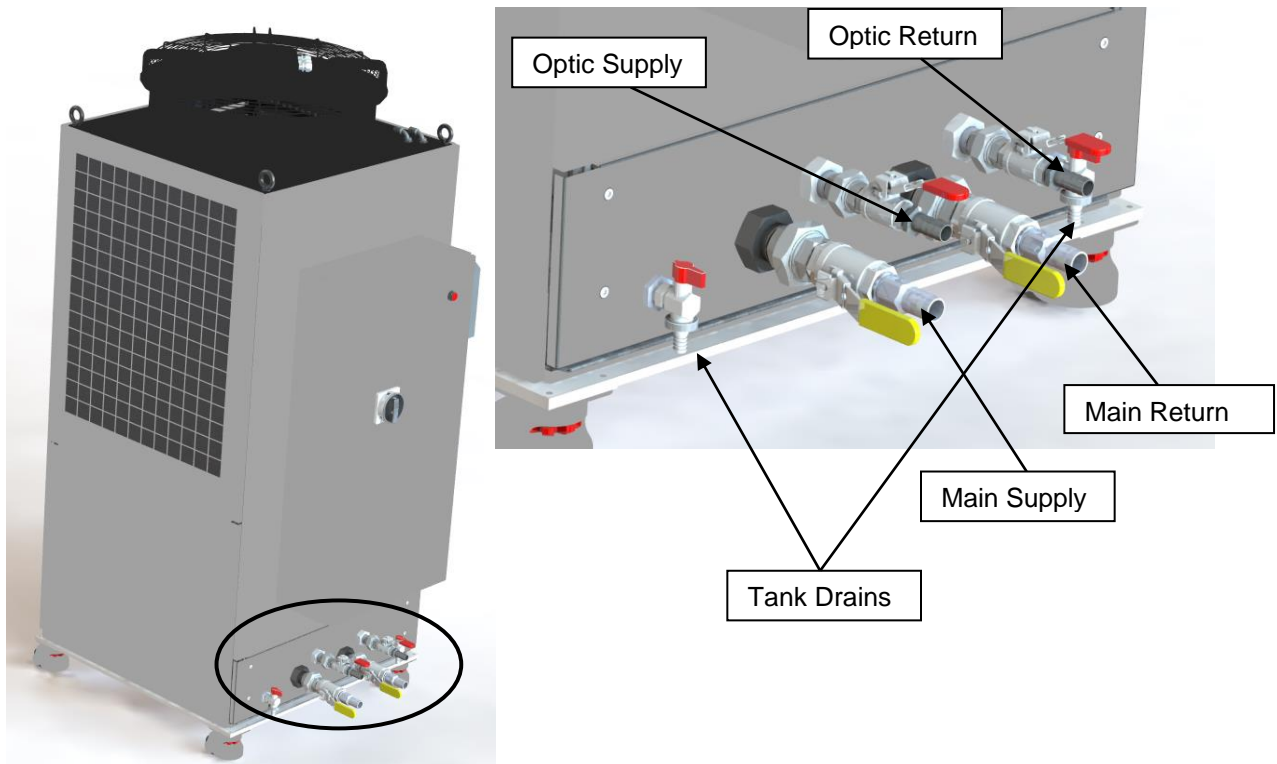

Figure 1: Water Connections

ADVICE:

Before starting up the chiller make sure, that:

- a) Laser and optic cooling circuit are connected with the laser
- b) All ball valves – **laser and chiller** – are open

5.6 Charging of the cooling system

5.6.1 Cooling water specification

Use conditioned water with maximum conductivity of 50 $\mu\text{S/cm}$. The hardness of the water should not exceed 0,25°dH.

° dH - German	° e - England	° fH - France	ppm - USA
0,25° dH	0,31325° e	0,445° fH	4,45 ppm CaCO ₃

5.6.2 Cooling water additives

A moderate chemical conditioning of the cooling water is important to protect the system against corrosion, maintenance of heat transfer and minimizing of bacteria inside the system. It's an important requirement to guarantee the continued operation of the laser and the chiller.

5.6.2.1 General

- a) Intention of this specification is to describe the minimum effort for a preventative chemical water conditioning.
- b) The water treatment concept includes necessary chemicals, test methods, service and equipment for operating and protecting the cooling water circuit.
- c) The water treatment concept is designed for a maximum system volume of 200 liters.
- d) Materials of the water system to be protected: Stainless steel, cooper and non-ferrous metal.

5.6.2.2 Chemicals

Water treatment is only allowed in the laser circuit. In the optic circuit it's not allowed to use any chemicals.

All chemicals are complied with legal requirements:

- a) These chemicals are not toxic for the employees if handled safely and reasonable precautions are taken.
- b) Effectiveness of the chemicals:

1) Corrosion	Minimization to industry standard
2) Coating and fouling	no
3) Biological fouling	no visible fouling
	no health risk
	Plankton < 10 ³ CFU/ml
	Pathogenic bacteria < 10 CFU/ml
	Foray and barm < 10 CFU/ml

A water treatment kit is included with each chiller. Instructions for using the kit are included in the kit. For additional kits, please contact IPG Service.

5.6.3 Start up laser circuit

When filling the tank with water use hose connections shown in the picture below. For the first filling you need about 120 litres of water.

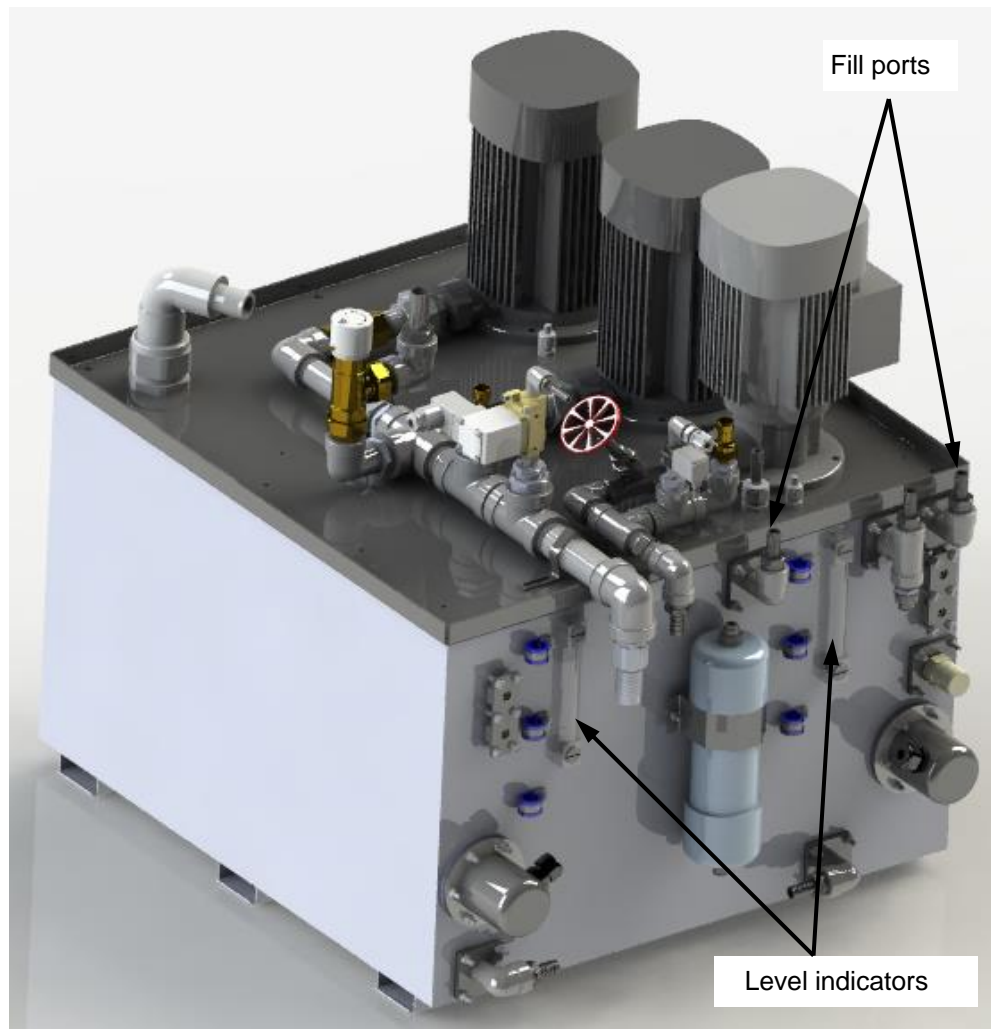

Figure 2: Filling the Tanks



ADVICE:

Make sure, that the temperature of the water does not exceed 30°C.

5.7 Choke valves

There is a choke valve installed on the water outlet of the optic pump. This valve allows the water pressure to be adjusted in the optic circuit if necessary.



5.8 Motor protection switches

Before starting up the chiller, switch the motor-circuit switches in ON-Position. Check if the adjusted currents are according to the currents given in the electric drawing.

5.9 Electrical connection

The chiller is completely wired and ready for operation. As soon as the laser has been connected to a three-phase power system and the circuit breaker is switched to ON-Position, the chiller will start operation when the following conditions are met:

- Fuse for chiller main power supply OK
- Fuse for chiller control voltage OK
- If activated, enabling of the chiller by the laser OK
- Chiller failure free

 DANGER	<p>DANGER:</p> <p>The electrical connection has to be made by a skilled and authorized worker according electric drawing.</p>
	<p>ADVICE:</p> <p>The chiller has to be connected with a clockwise rotating field. The factory warranty is void if the electrical connections to the chiller are not performed properly.</p>

5.10 Checking the electrical rotating field

The pumps should now be running. As soon as the water temperature exceeds the set point, the compressor will start.

Please look at the pump motors. You will find an arrow which indicates the proper direction of rotation. Check, if the direction of the pump rotation is according to the arrow.

Take a sheet of paper and put it in front of the air outlet grid. If the pump motor rotation is correct, the paper sheet will flutter in the airflow.

The correct rotation of the compressor is checked by the control board. If the compressor is rotating in the wrong direction, the control board will switch off the chiller.



Checking rotation of the pump



Checking rotation of the fan – sheet of paper must be sucked

	<p>ADVICE:</p> <p>Always ensure that the pumps turn in the proper direction. If direction of rotation is wrong, the electrical connection needs to be corrected.</p> <p>In case of wrong rotation, disconnect the chiller via main switch using lock-out/tag-out procedures and unplug the chiller from voltage supply. Phases L1 and L2 have to be reversed by and an authorized skilled worker.</p>
---	--

5.11 Ventilating the pump

Immersion pumps are self cooling. Ventilating the pump is not necessary.

	<p>ADVICE:</p> <p>During the initial start up of the chiller, the pipes and the laser modules will begin filling with water. This will cause the water level to fall.</p> <p>Make sure, that water according item 5.6 is available so that you can refill the tank when necessary.</p> <p>The water level inside the tank will be controlled by level indicators. If the water level is too low, the chiller will be switched off.</p>
---	---

6 PIPING AND INSTRUMENTS DIAGRAM

Hydraulik Module

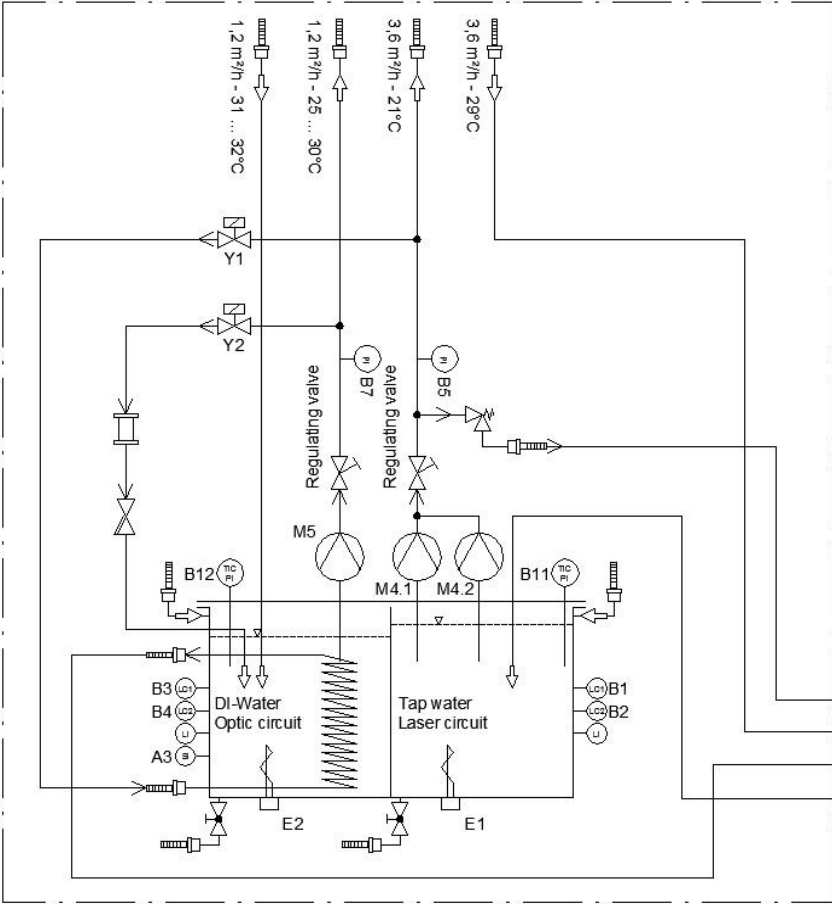

Refrigerant Module

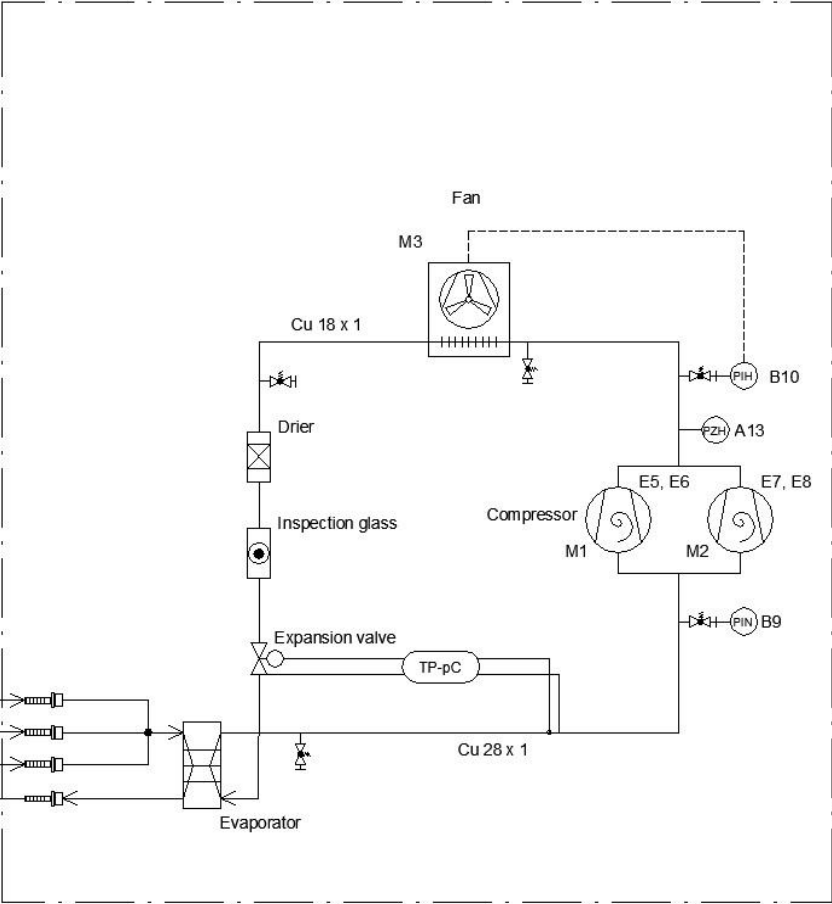

Figure 3: Piping and Instruments Diagram (P&I Diagram)

6.1 Refrigerant module

Refrigerant Module

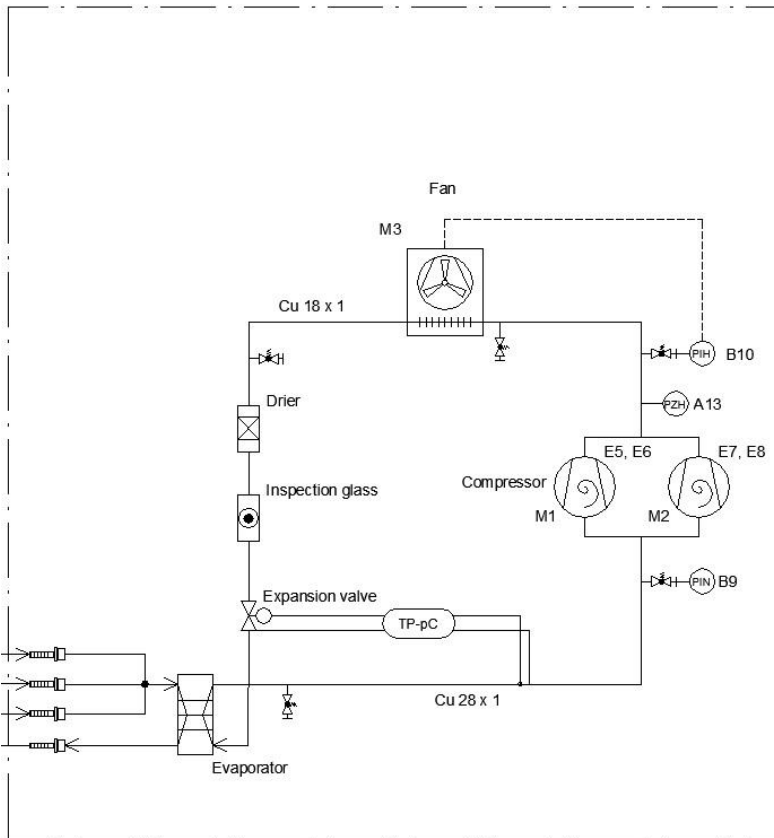

Figure 4: P&I Diagram refrigerant module

Component name	Electric designation	Measurement / Operation
Compressor 1	M1	
Compressor 2	M2	
Low pressure sensor	B9	Evaporating pressure
High pressure sensor	B10 (B15)	Condensing pressure
High pressure control	A13 (PS2)	Emergency cut-out @ 28 bar
Fan	M3	

The compressors (M1 & M2) pull the low pressure refrigerant out of the evaporator. The low pressure sensor (B9) monitors the pressure. If the evaporating pressure goes lower than 3.9 bar, there is the danger of icing the water section of the heat exchanger. To avoid this, the controller switches off the compressor. In this case the alarm message **“Refrigerant Circuit / Low Pressure”** will be displayed.

The compressor increases the pressure of the refrigerant gas from evaporating pressure to condensing pressure. During this process the refrigerant is superheated. If any error causes the condensing pressure to go higher than 28 bar, the high pressure switch (A13, PS2) will stop the chiller immediately. Such a failure is by definition, an emergency shut off. Therefore this failure has to be reset manually at the high

pressure switch. In this case the alarm message **“Refrigerant Circuit / High Pressure”** will be displayed. For monitoring of the liquefying pressure, the high pressure sensor (B10, B15) is used.

The compressed refrigerant is liquefied inside the air cooled condenser. Due to heat of condensation the air will increase in temperature.

The liquid refrigerant flows through the dehumidifier and the inspection glass to the expansion valve. The expansion valve reduces the pressure of the liquid from condensing pressure to evaporating pressure. After expanding of the refrigerant, it enters the evaporator as a liquid / gas mixture. Inside the evaporator the refrigerant will be evaporated by the heat of the warm water coming from the laser modules. After this the refrigerant vapour is drawn by compressor (M1 & M2) and the refrigeration circuit starts again.

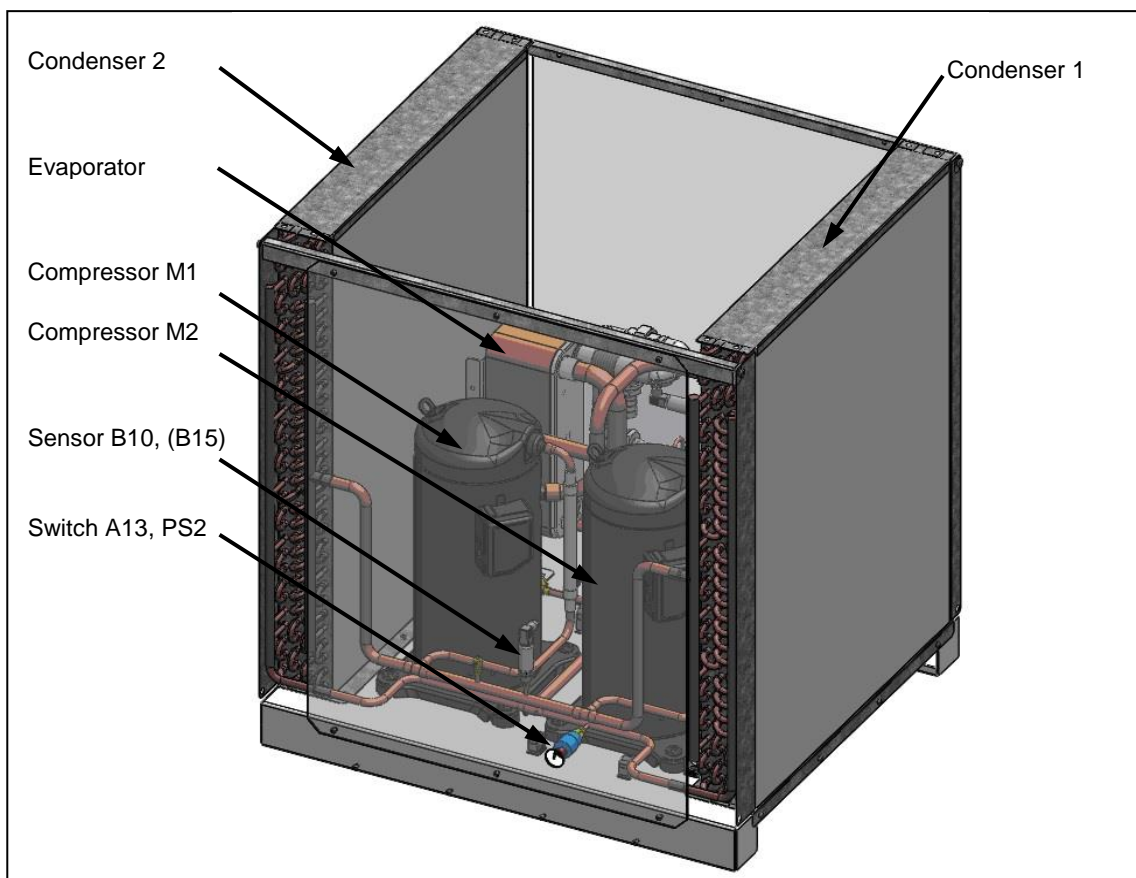

Figure 5: Refrigerant module

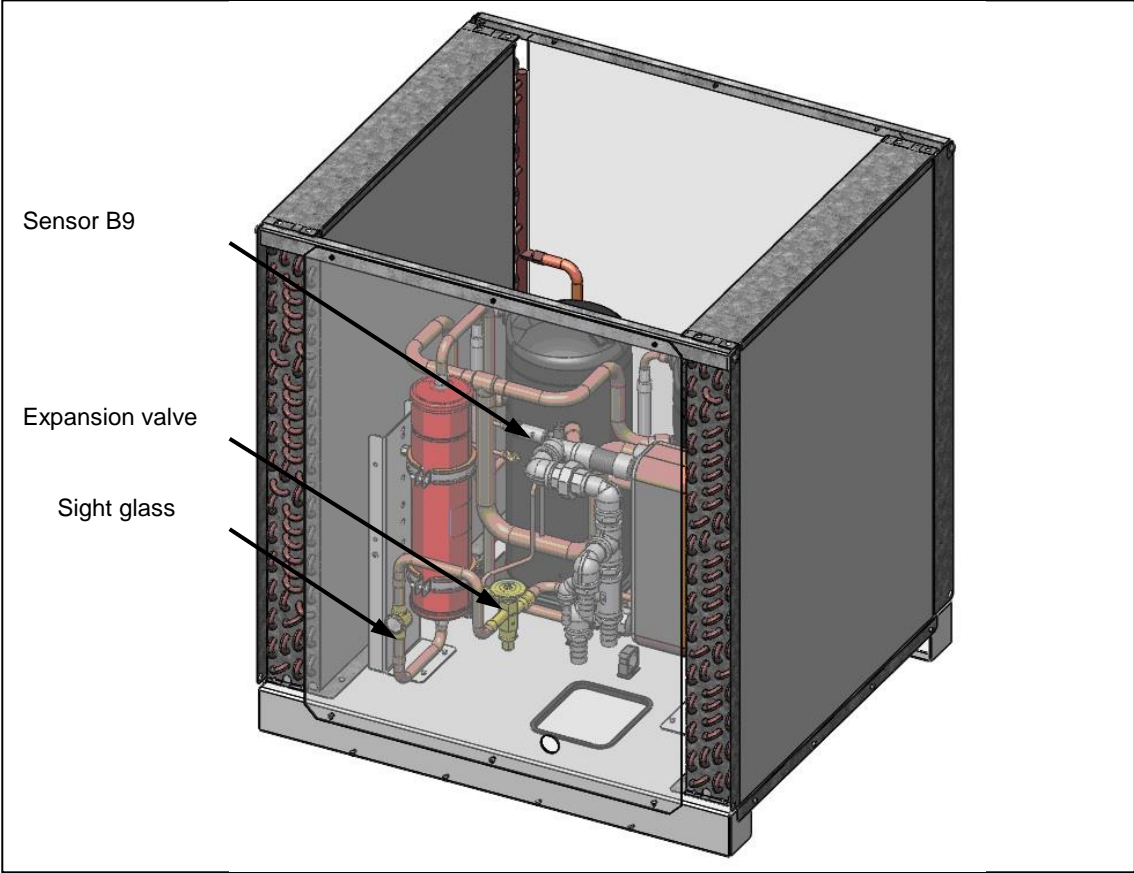

Figure 6: Refrigerant module

6.2 Hydraulic module

Hydraulik Module

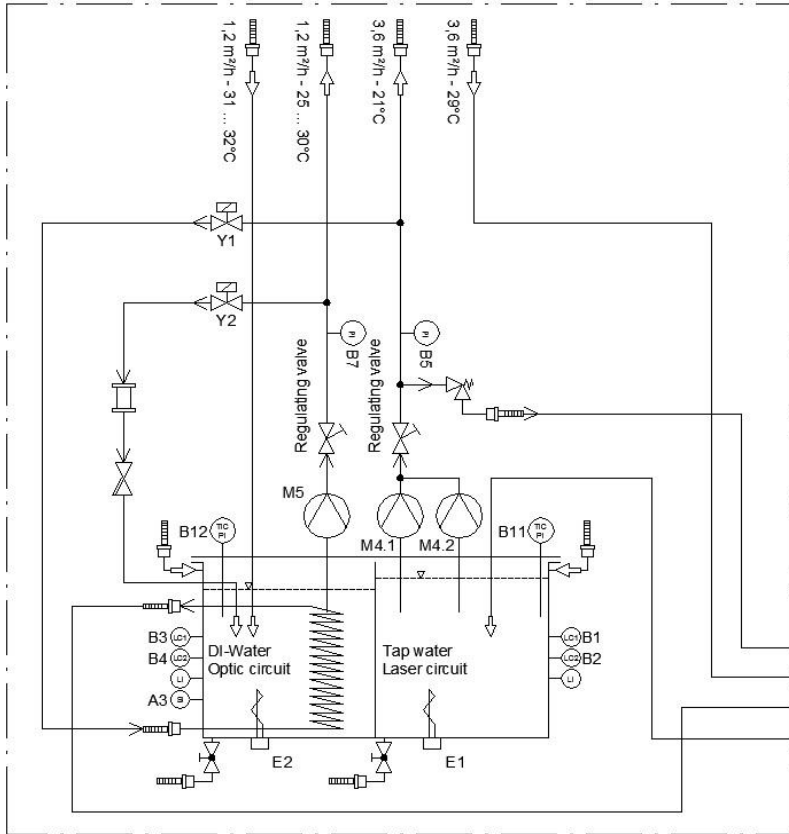

Figure 7: P&I Diagram hydraulic module

6.2.1 Laser cooling circuit

The cooling water for the laser circuit is supplied by the pumps (M4.1 & M4.2). If the cooling water temperature is too low, the heater (E1) will heat up the water to the required temperature.

Component name	Electric designation	Measurement / Operation
Water pump 1 laser circuit	M4.1	
Water pump 2 laser circuit	M4.2	
Tank heater laser circuit	E1	
Liquid level switch	B1	Refilling required
Liquid level switch	B2	Dry run protection pump
Pressure sensor	B5	Laser cooling circuit
Temperature sensor 1	B11	Laser cooling circuit

6.2.2 Optic cooling circuit

The cooling water for the optic circuit is supplied by pump (M5). If the cooling water temperature is too low, the heater (E2) will heat up the water to the required temperature.

Component name	Electric designation	Measurement / Operation
Water pump optic circuit	M5	
Tank heater optic circuit	E2	
Magnetic valve	Y1 (SOL 1)	Cooling of the optic circuit
Magnetic valve	Y2 (SOL 2)	Conductivity of DI-Water
Liquid level switch	B3	Refilling required
Liquid level switch	B4	Dry run protection pump
Pressure sensor	B7	Pressure optic circuit
Temperature sensor	B12	Temperature optic circuit
Conductivity sensor	A3 (A4)	Conductance optic circuit

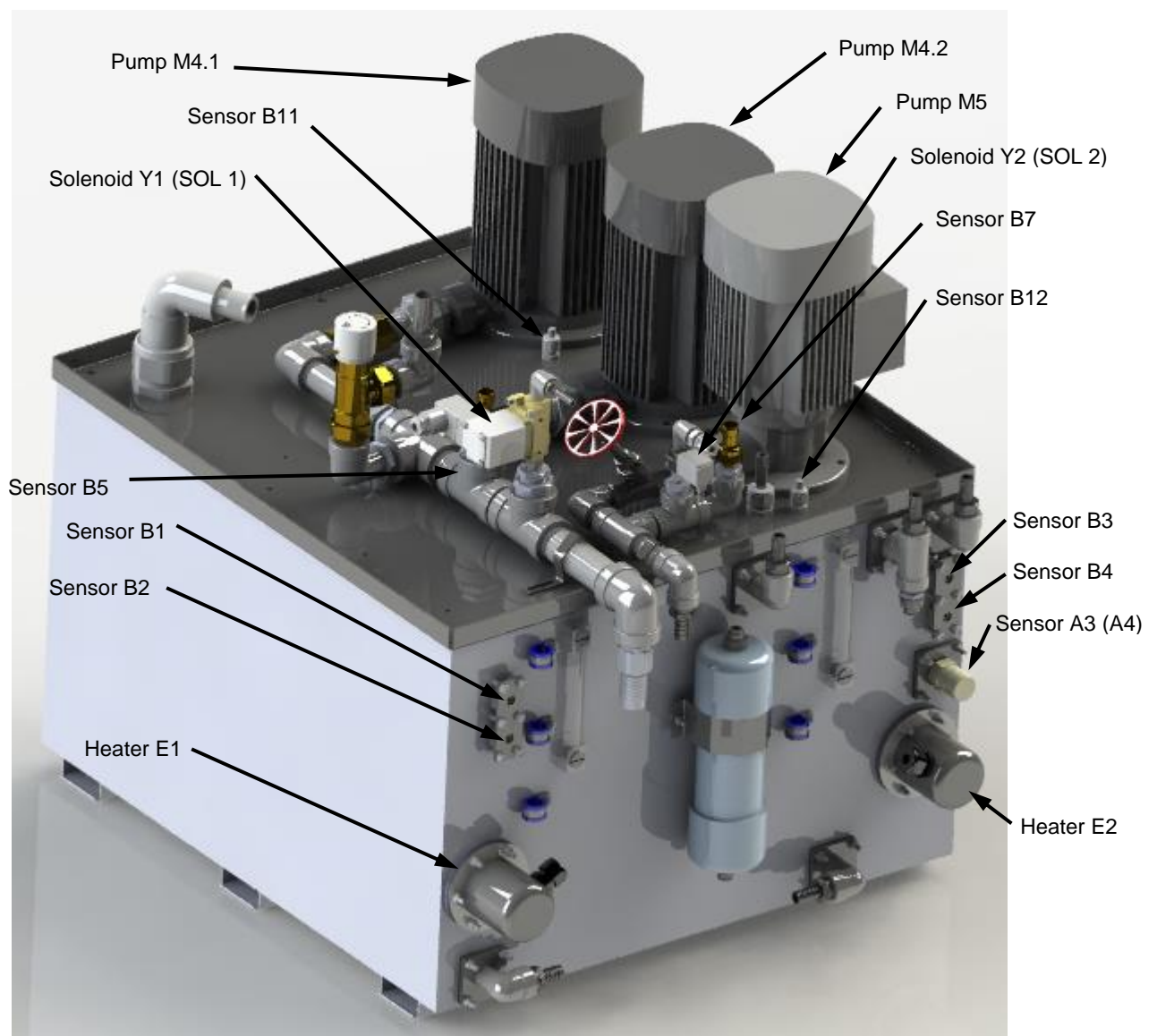





Figure 8: Hydraulic module

7 ADJUSTING AND MAINTENANCE WORK

 DANGER	<p>DANGER:</p> <p>It is prohibited to do trouble-shooting or maintenance work while the electrical power is on. Even if the chiller is OFF, parts of the electrical circuit will be under high voltage until the main circuit breaker is opened.</p> <p>Do not attempt to perform any work on the chiller unless the unit is disconnected from the power supply</p> <p>The electrical diagram has to be reviewed and understood.</p> <ul style="list-style-type: none"> - In emergencies the chiller has to be switched off by the main circuit breaker - Always follow accident prevention regulations - The electrical connection must be according to EN, VDE- / IEC-Norms or according to the corresponding local authority - The safety devices must not be deactivated
 WARNING	<p>WARNING:</p> <p>Adjusting and maintenance work is only allowed for skilled workers.</p> <p>Only properly trained technicians are allowed to adjust and maintain the electrical / refrigerant components.</p> <p>Anyone working on the chiller must be protected by personal protective equipment.</p>

7.1 Intended usage of the chiller

The chiller is designed for cooling water. The chiller is only to be operated with the appropriate IPG laser.

 DANGER	<p>DANGER:</p> <p>The chiller is designed for cooling water. The use for cooling of ignitable or explosive materials is prohibited.</p> <p>The chiller is to be used exclusively with the appropriate IPG laser.</p>
--	---

7.2 Switching ON

As soon as the main switch is switched on, the pumps will start operation. If tap water temperature exceeds the set point, the compressor will start operation after the input delay time has completed and following items are fulfilled:

- Main chiller fuse OK (see electrical diagram)
- Chiller control voltage fuse OK (see electrical diagram)
- If activated, chiller enabled from laser
- No leakage error
- No malfunction in the chiller

7.3 Switching OFF

The chiller should be switched off by the main circuit breaker.

7.4 Adjusting work

7.4.1 Bypass valve

**ADVICE:**

Adjusting of the bypass valve should be performed only by a skilled worker.

If the cooling water flow needed for the laser system is lower than the minimum water flow of the chiller, the bypass valve has to be adjusted.

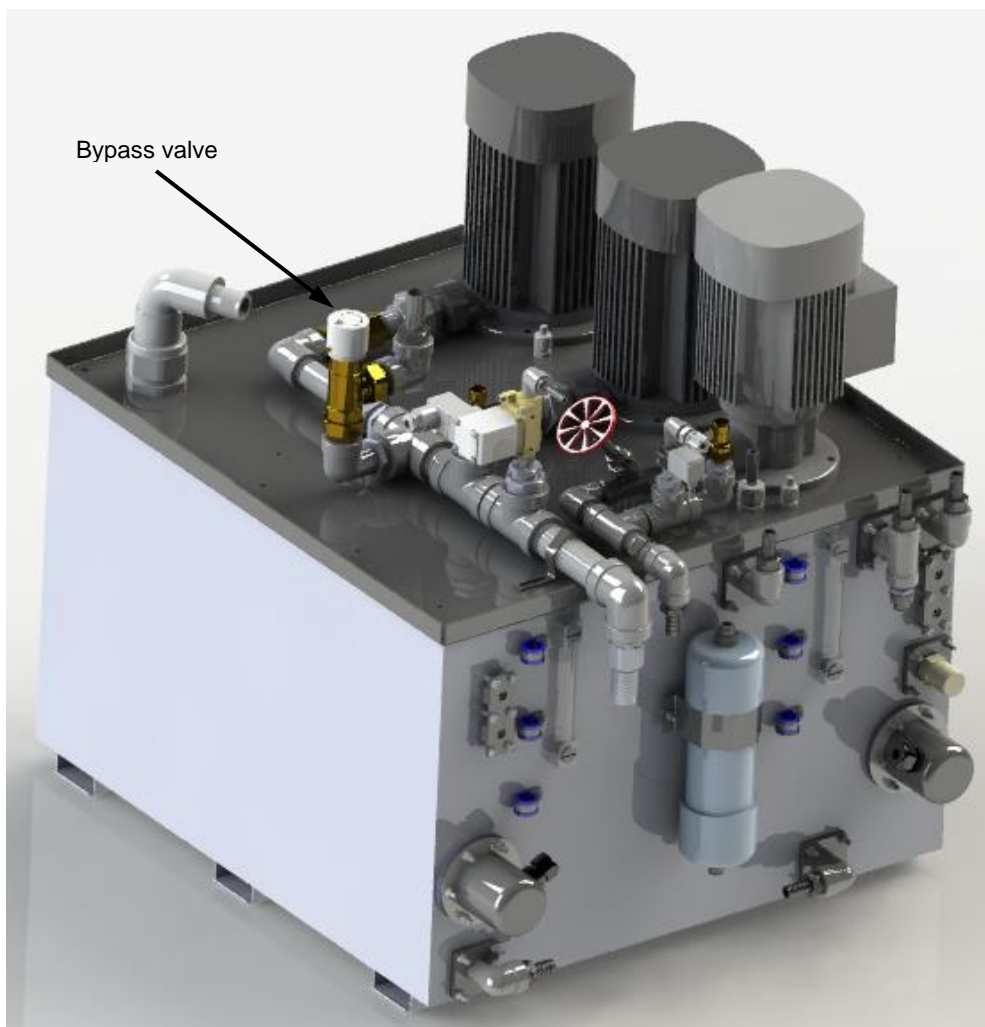

Figure 9: Bypass valve

Loosen the locking screw and adjust the valve as needed for 50 or 60 Hz operation. Once the valve is adjusted, tighten the locking screw. The laser supply ball valve should be closed while performing this adjustment.

a) Setting of the bypass valve for 60 Hz operation:

The valve is set at the factory for 5.0 bar, which is the appropriate setting for 60 Hz operation

b) Setting of the bypass valve for 50 Hz operation:

It is recommended for 50 Hz operation that the valve be adjusted to 3.5 bar.

**7.4.2 Changing the connecting voltage****7.4.2.1 From 50 Hz to 60 Hz**

Set the bypass valve to 5.0bar (see 7.4.1).

7.4.2.2 From 60 Hz to 50 Hz

Set the bypass valve to 3.5 bar (see 7.4.1).

**DANGER****DANGER:**

Even if the chiller is OFF, parts of the electrical circuit will be under high voltage until the main circuit breaker is opened.

Do not attempt to perform any work on the chiller unless the unit is

	<p>disconnected from the power supply</p> <p>The electrical diagram has to be reviewed and understood.</p> <ul style="list-style-type: none"> - In emergencies the chiller has to be switched off by the main circuit breaker - Always follow accident prevention regulations - The electrical connection must be according to EN, VDE- / IEC-Norms or according to the corresponding local authority - The safety devices must not be deactivated
 WARNING	<p>WARNING:</p> <p>Maintenance work is only allowed for skilled workers.</p> <p>Only properly trained technicians are allowed to adjust and maintain the electrical components.</p> <p>Maintenance work at the refrigerant circuit is only allowed for HVAC Technician.</p> <p>Anyone working on the chiller must be protected by personal protective equipment.</p>

7.5 Maintenance work

7.5.1 Inspection

 WARNING	<p>WARNING:</p> <p>In case of irregular behaviour of the mechanical working components or abnormal noise, the chiller must be switched off by the main circuit breaker.</p>
---	--

Perform the following inspection work on a weekly schedule:

- Check for irregularities of the mechanical working components
- Abnormal noise
- Check the water level
- Check all displayed temperatures and pressures
- Check the conductivity
- Check the refrigerant filling in the sight glass
- Check the refrigerant pipes for oil leakage

This inspection should be documented in a machine maintenance log book.

7.5.2 Pumps

The bearings and the wave seals of the pump are maintenance-free. If the pumps are not in operation for more than one year (tank empty), apply a few drops of silicone oil on the spindle between the head piece and coupling. For this you must disassemble the coupling protection cover.

The motor bearings are maintenance-free.

If the pumps are out of operation for longer than 6 month, the motor bearings should be lubricated.

7.5.3 DI-Cartridge

LaserNet will give a warning if the conductivity of the DI-Water is out of range. This is an indication that the DI-Cartridge should be replaced.

The DI-Cartridge and the water should be changed every 6 months.

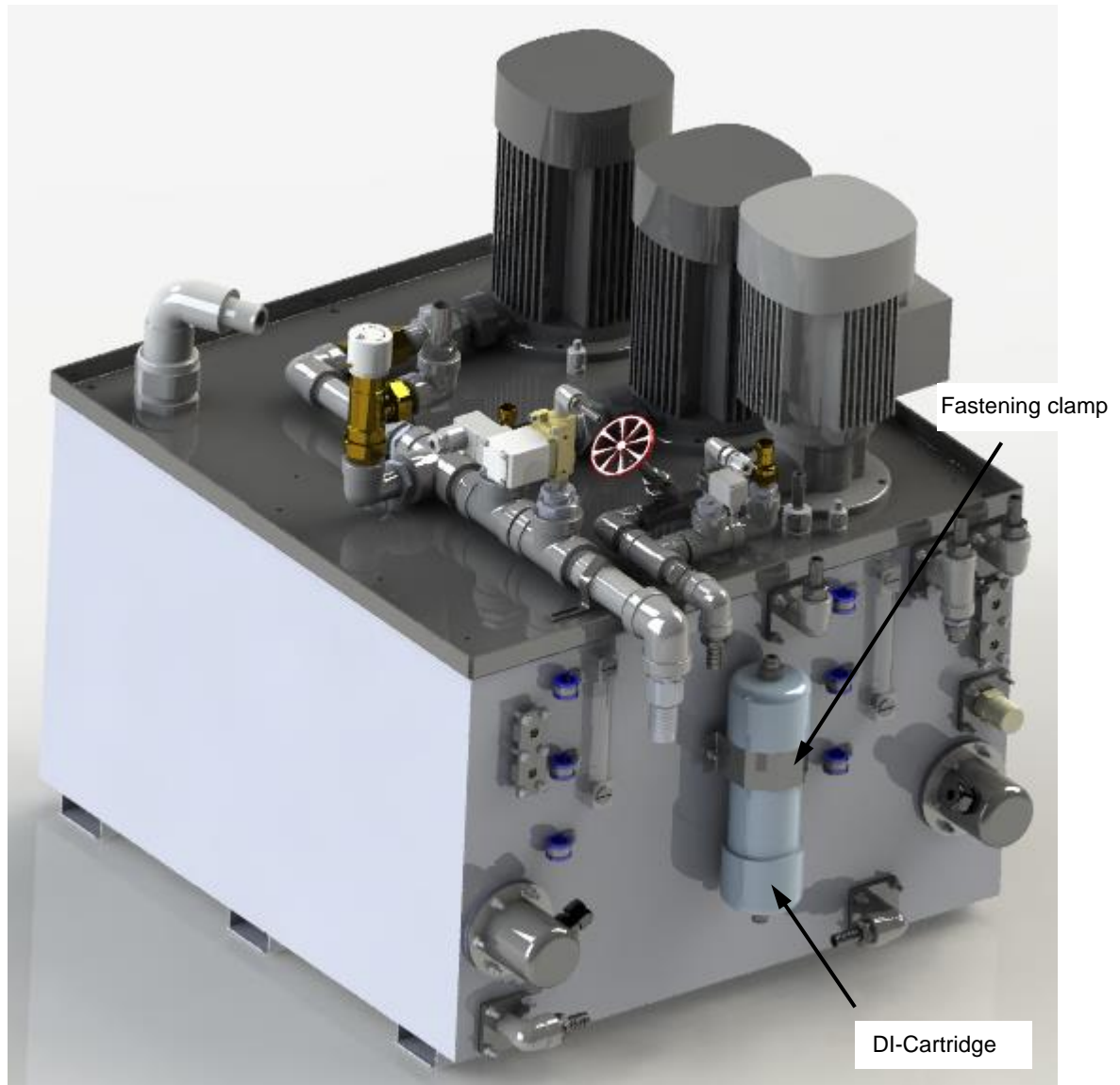

Figure 10: Changing of the DI-Cartridge

7.5.4 Changing the air filter

Disassemble the air inlet grids and change the air filters. Please contact our service department for a new filter.

7.5.5 Checking the refrigerant filling

Locate the inspection glass. (See 6.1)

During the initial start period of the compressor you may see some bubbles inside the site glass. After about 30 seconds all bubbles should disappear, if not there may be a problem with the refrigerant. Check the evaporating temperature. If the evaporating temperature is below 5°C, the refrigerant maybe low. Please get in contact with our service department.

The moisture content of the refrigerant will be indicated by a color scale. If the scale indicates "Wet" (corresponding to the color PINK or YELLOW – depending on manufacturer) please contact our service department.

7.5.6 Checking the refrigerant circuit for oil leakage

Refrigerant leaks always have oil with them. If oil leakages are found, please contact our service department.

7.5.7 Cooling water of the laser circuit

Minimum maintenance for the cooling water circuit:

- a) Change the water every 6 month
- b) In case of algae formation, chemical cleaning and disinfection may be necessary. Please call our service department
- c) As optional chemical and microbiological water analysis

The chemical kit for water maintenance is included in delivery of the chiller. It is recommended that the water be changed in both tanks and chemicals be refreshed in 6-month intervals. Please contact IPG service for additional kits.

7.6 Warnings and Alarms

The following maintenance work will be requested in LaserNet:

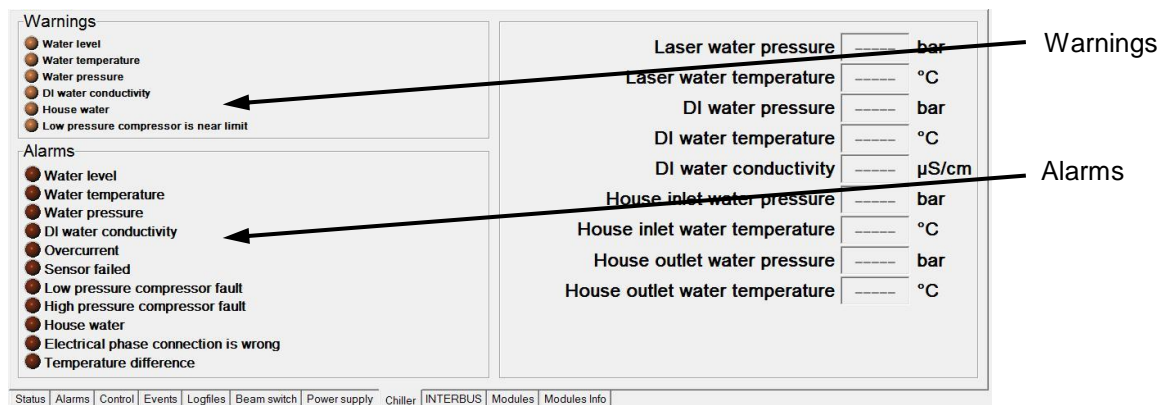

Figure 11: LaserNet – Warnings and Alarms

7.6.1 Water level warning

Warning indication:

Warning lamp “**Warnings / Water level**” is lighting yellow.

Action:

This message will not influence the chiller operation. It is only warning message that water refilling is required. Check water level of tap and DI water. Refill water if necessary.

If the water level is decreased further more and is below the threshold, the chiller will be switched off.

Reset of the warning:

After refilling water, the warning light will be switched off automatically.

	<p>ADVICE:</p> <p>Make sure, that the temperature of the water does not exceed 30°C.</p>
---	---

7.6.2 Water temperature warning

Warning indication:

Warning lamp “**Warnings / Water temperature**” is lighting yellow.

Action:

This message will not influence the chiller operation. It is only a warning message that a temperature value is near limit.

Please check page “**Events**” in LaserNet for further information.

- a) Tap water temperature near limit

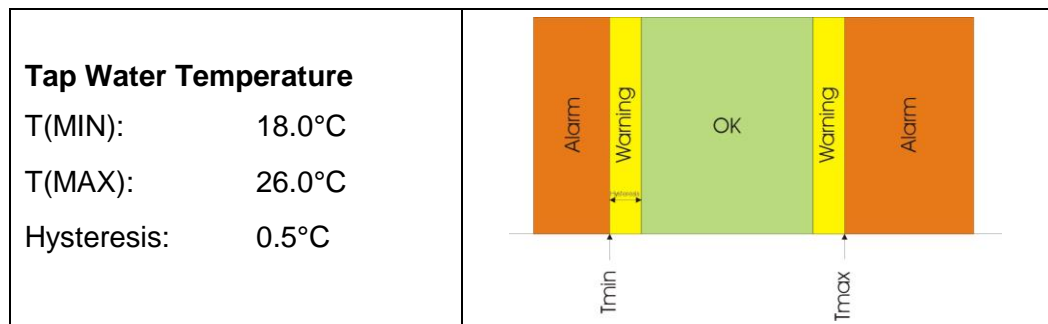

Following conditions will activate this warning message:

- Tap water temperature between 18 and 18.5°C (near minimum limit)
- Tap water temperature between 25.5 and 26°C (near maximum limit)

b) DI water temperature near limit

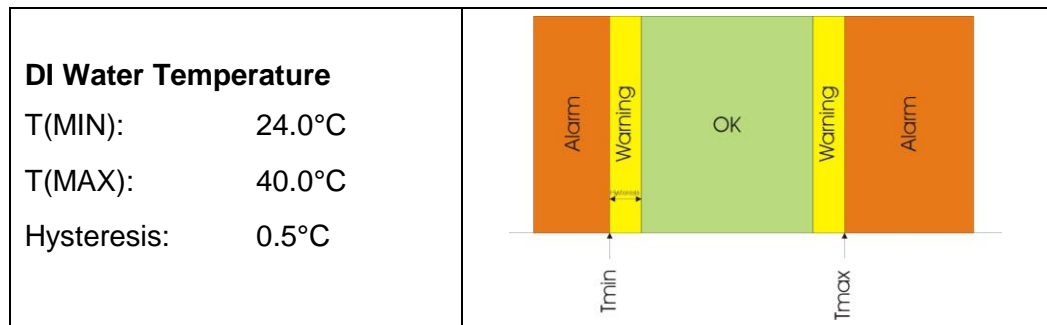

Following conditions will activate this warning message:

- DI water temperature between 24 and 24.5°C (near minimum limit)
- DI water temperature between 39.5 and 40°C (near maximum limit)

7.6.3 Water pressure warning

Warning indication:

Warning lamp “**Warnings / Water pressure**” is lighting yellow.

Maintenance action:

This message will not influence the chiller operation. It is only a warning message that a pressure value is near limit.

Please check page “**Events**” in LaserNet for further information.

a) Tap water pressure near limit

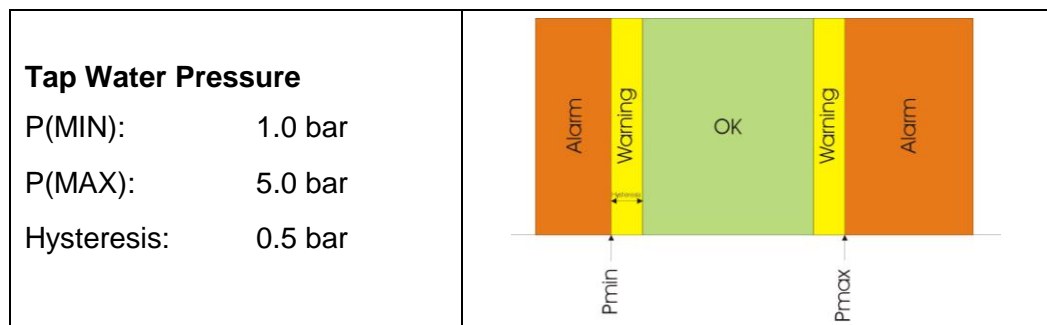

Following conditions will activate this warning message:

- Tap water pressure between 1.0 and 1.5 bar (near minimum limit)
- Tap water pressure between 4.5 and 5.0 bar (near maximum limit)

b) DI water pressure near limit

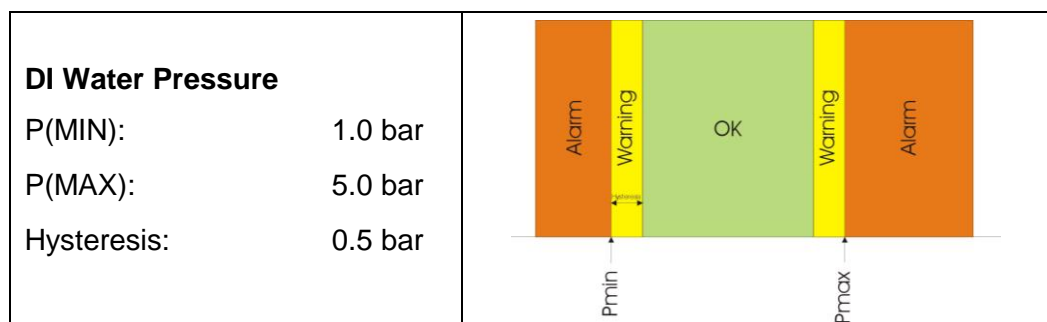

Following conditions will activate this warning message:

- DI water pressure between 1.0 and 1.5 bar (near minimum limit)
- DI water pressure between 4.5 and 5.0 bar (near maximum limit)

7.6.4 DI water conductivity

Warning indication:

Warning lamp “**Warning / DI water conductivity**” is lighting yellow.

Maintenance action:

This message will not influence the chiller operation. It is only a warning message that the water conductivity is near limit.

Following conditions will activate this warning message:

- DI water conductivity between 35 and 45 $\mu\text{S/cm}$

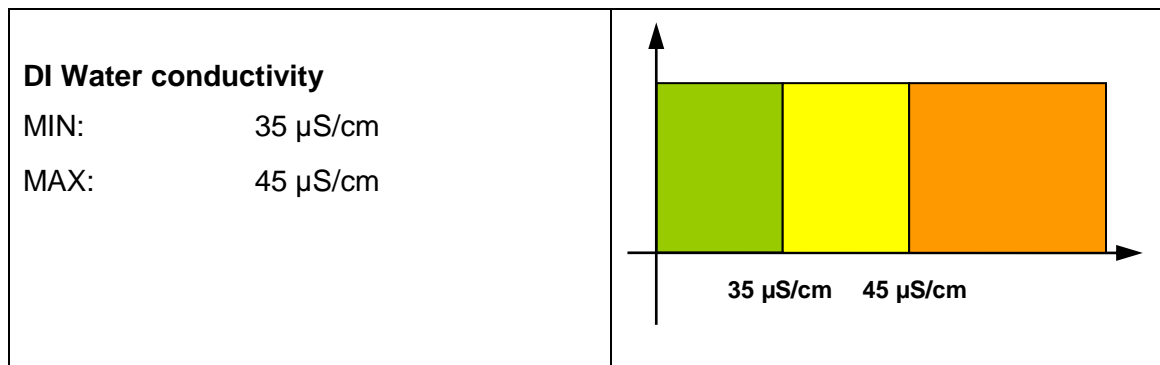

Change the DI cartridge according 7.5.3

7.6.5 Low pressure compressor is near limit

Warning indication:

Warning lamp “**Warning / Low pressure compressor is near limit**” is lighting yellow.

Maintenance action:

This message will not influence the chiller operation. It is only a warning message that the evaporating pressure is near limit.

Following conditions will activate this warning message:

- Low pressure refrigerant circuit between 2 and 4°C

For further information please see 8

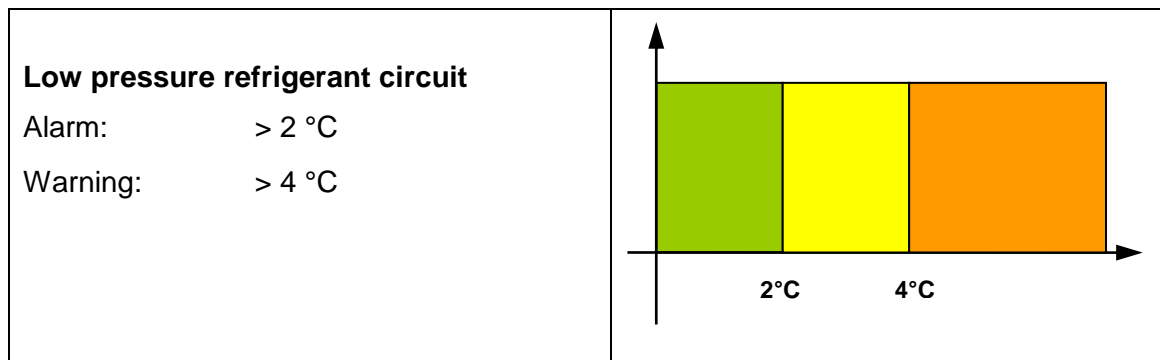

8 INTERRUPTION OF OPERATION

 DANGER	<p>DANGER:</p> <p>It is prohibited, to do trouble shooting or maintenance work while the electrical power is on. Even if the chiller is OFF, parts of the electrical circuit will be under high voltage until the main circuit breaker is opened.</p> <p>Do not attempt to perform any work on the chiller unless the unit is disconnected from the power supply</p> <p>The electrical diagram has to be reviewed and understood.</p> <ul style="list-style-type: none">- In emergencies the chiller has to be switched off by the main circuit breaker- Always follow accident prevention regulations- The electrical connection must be according to EN, VDE- / IEC-Norms or according to the corresponding local authorities- The safety devices must not be deactivated
--	---

8.1 Repairs

 WARNING	<p>WARNING:</p> <p>A repair of the machinery is only allowed to be done by specialised companies. Please contact our service department in case of failure.</p>
---	--

8.2 Alarm messages

 WARNING	<p>WARNING:</p> <p>In cases of interruptions of operation that cannot be solved with the help of this manual please disconnect the chiller from the net and contact our service department.</p> <p>The operating company has to take care that repairs are only done by specialised personnel.</p>
---	---

All warning messages will be indicated in LaserNet. To get an overview, please go to the page "**Chiller**"

For further details please go to the page "**Events**". Here you get detailed information about all active alarm and warning messages.

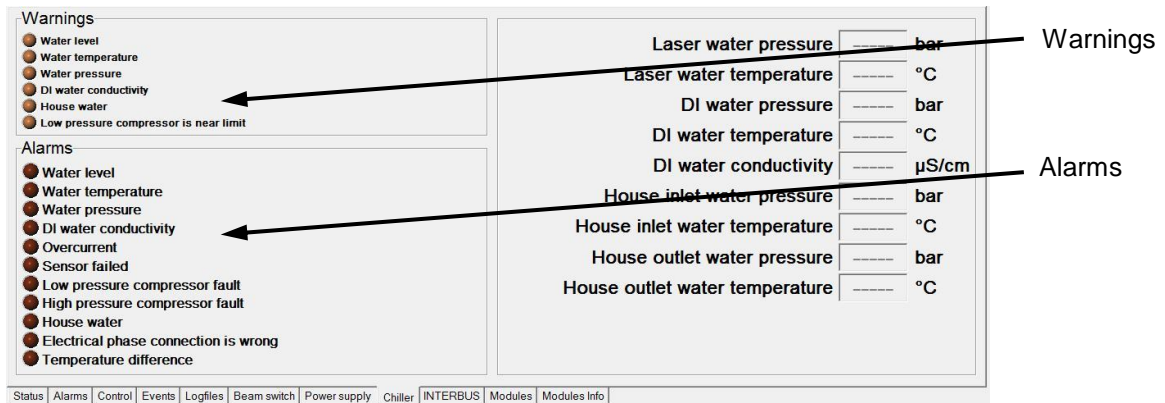

Figure 12: LaserNet – Alarm messages page Chiller

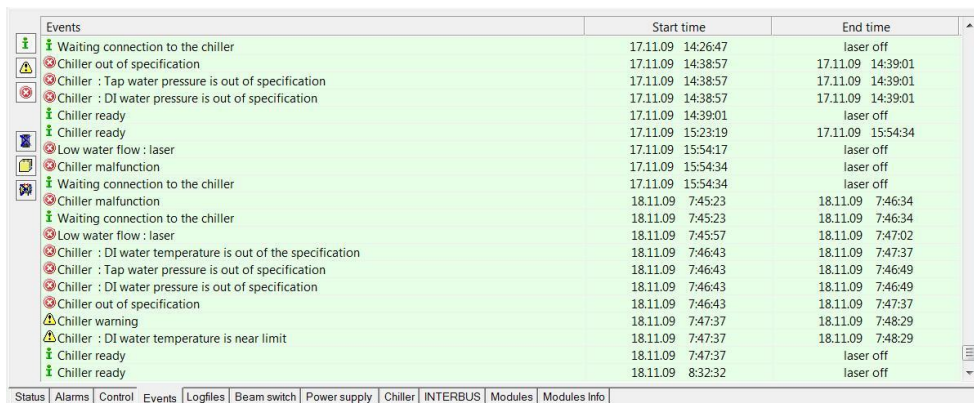

Figure 13: LaserNet – Alarm messages page Events

8.2.1 WATER LEVEL ALARM

Alarm indication:

The alarm lamp “**Alarms / Water level**” is lighting red. In the page “**Events**” you will find detailed information about active alarm message:

- a) Fill up tap water tank
- b) Fill up DI water tank

Action:

This alarm will stop the chiller operation. Check the water level of tap and DI water and refill.

Reset of the alarm:

After refilling tap and DI water, you can reset warning message. The red light will be switched off.

ADVICE:

Make sure, that the temperature of the water does not exceed 30°C.

8.2.2 WATER TEMPERATURE ALARM

Alarm indication:

The alarm lamp **“Alarms / Water temperature”** is lighting red. In the page **“Events”** you will find detailed information about active alarm message:

- a) Tap water temperature is out of the specification
- b) DI water temperature is out of the specification

Action:

This alarm will not stop chiller operation. It is only warning message that tap or DI water temperature is out of specification. Following conditions will activate this alarm message:

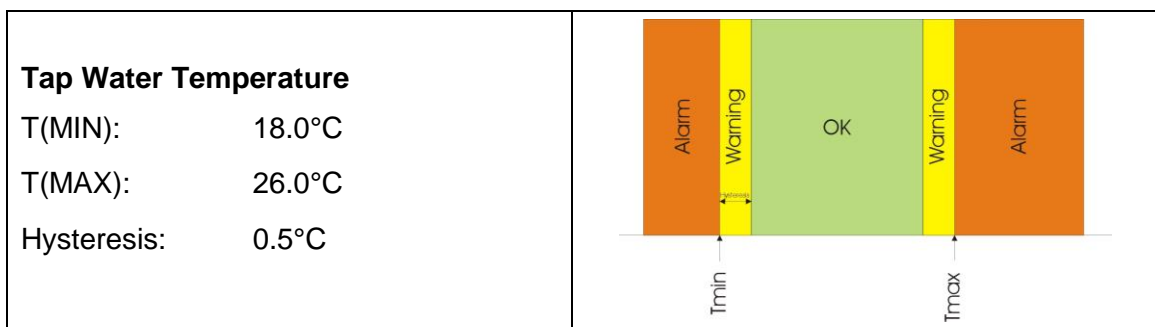

- Tap water temperature lower than T(MIN)
- Tap water temperature higher than T(MAX)

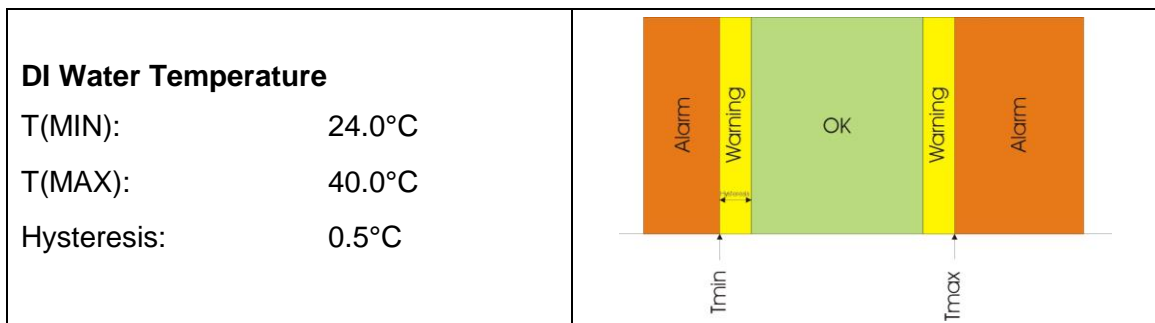

- DI water temperature lower than T(MIN)
- DI water temperature higher than T(MAX)

If you start up the laser system after a long down time, please wait until preheating of the water is finished.

If the alarm is still present after finishing of preheating, go to page **„Events“** to check if another alarm is active. In case of an active alarm message solve this problem first.

If no other alarm message is active, go to item **Error! Reference source not found.** to check if the default settings are correct.

If the default settings are OK, please call our service department.

Reset of the alarm:

After solving the problem, you can reset the alarm by pushing the reset button in LaserNet. The red light will be switched off.

8.2.3 WATER PRESSURE ALARM

Alarm indication:

The alarm lamp “**Alarms / Water pressure**” is lighting red. In the page “**Events**” you will find detailed information about active alarm message:

- a) Tap water pressure is out of specification
- b) DI water pressure is out of specification

Action:

This alarm will not stop chiller operation. It is only warning message that tap or DI water pressure is out of specification. Following conditions will activate this alarm message:

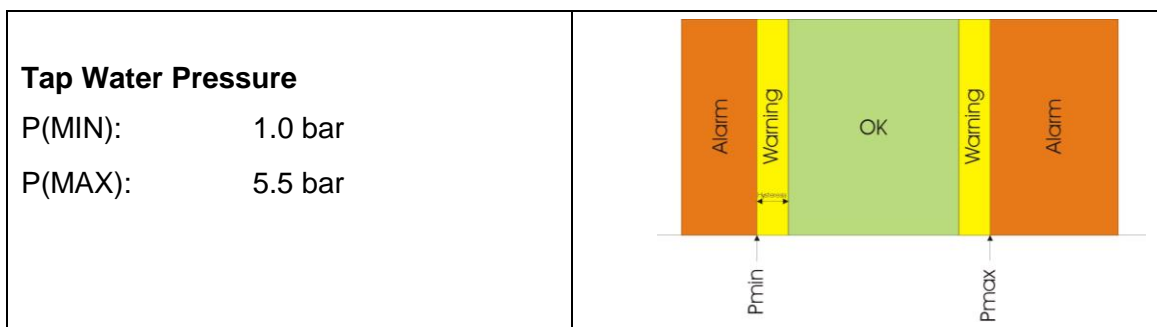

- Tap water pressure lower than 1.0 bar
- Tap water pressure higher than 5.5 bar

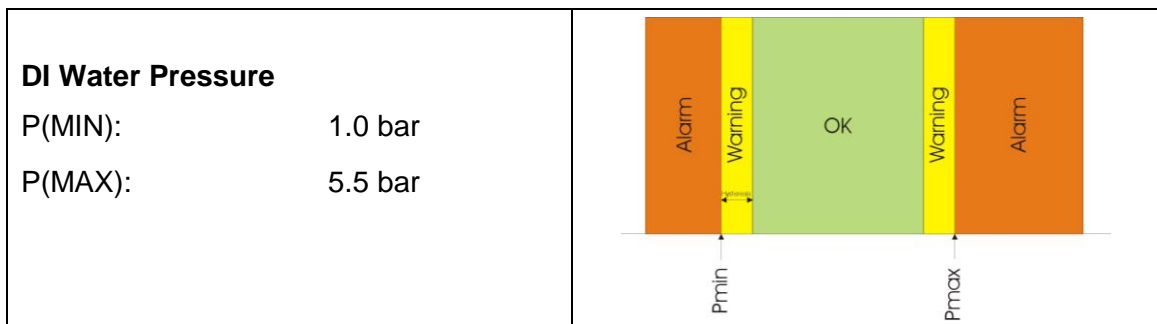

- DI water pressure lower than 1.0 bar
- DI water pressure higher than 5.5 bar

Go to page “**Events**” to check if another alarm is active. In case of an active alarm message solve this problem first.

If no other alarm message is active, go to item **Error! Reference source not found.** to check if the default settings are correct.

After checking the default settings go to item 8.4 and check the point’s listed in the table.

If you could not solve the problem with the information given by this manual, please call our service department.

Reset of the alarm:

After solving the problem, you can reset the alarm by pushing the reset button in LaserNet. The red light will be switched off.

8.2.4 DI WATER CONDUCTIVITY ALARM

Alarm indication:

The alarm lamp **“Alarms / DI water conductivity”** is lighting red. In the page **“Events”** **“DI water conductivity is too high”** will be indicated.

Action:

Following conditions will activate this warning message:

- DI water conductivity less than 30 $\mu\text{S/cm}$
- DI water conductivity greater than 50 $\mu\text{S/cm}$

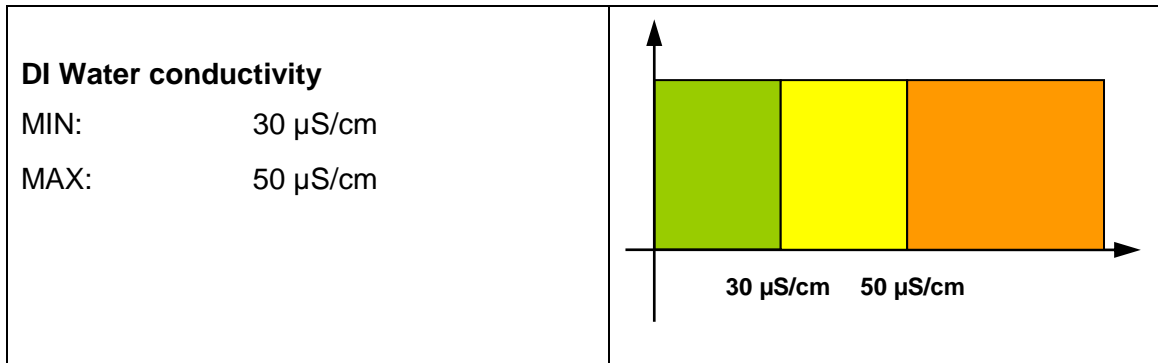

This alarm will stop chiller operation. Change DI cartridge according item 7.5.3.

Reset of the alarm:

After solving the problem, you can reset the alarm by pushing the reset button in LaserNet. The red light will be switched off.

8.2.5 OVERCURRENT ALARM

8.2.5.1 Laser cooling circuit – Pump over current

Alarm indication:

The alarm lamp **“Alarms / Overcurrent”** is lighting red. In the page **“Events”** **“Overcurrent of tap water pump”** will be indicated.

Action:

This alarm will stop chiller operation. Please check following reasons step by step:

Failure	Reason	Corrective
Missing of one phase	a) Power fault b) Phase not connected	a) Check the power supply b) Check if all phases are connected at the corresponding point inside the control cabinet
Too high flow	a) Optic Pump is operated outside characteristic curve	a) Reduce water flow by closing the regulating valve for the pump (M5).

Bad line voltage	a) Line voltage outside tolerance	a) Please check that the line voltage is within the specified limits
Bad line frequency	a) Frequency outside tolerance	a) Please check that the line frequency is within the specifications
Defective motor	a) Winding defect b) Motor mechanically locked	a) Replace the motor
Defective wire connection to the motor	a) Bad wire connection	a) Check the wire connections to the motor
Defective motor overload switch	a) Defective motor overload switch	a) Replace the motor overload switch

Reset of the alarm:

After resolving the problem:

- Reset the motor protection switch in position 1
- Reset by pushing reset button in LaserNet

8.2.5.2 Optic cooling circuit – Pump over current

Alarm indication:

Alarm lamp “**Alarms / Overcurrent**” is lighting red. In the page “**Events**” “**Overcurrent of DI water pump**” will be indicated.

Action:

This alarm will stop chiller operation. For possible reasons please see table 8.2.5.1.

Reset of the alarm:

After resolving the problem:

- Reset the motor protection switch in position 1
- Reset by pushing reset button in LaserNet

8.2.5.3 Laser cooling circuit – Over current tank heater

Alarm indication:

Alarm lamp “**Alarms / Overcurrent**” is lighting red. In the page “**Events**” “**Overcurrent of tap water heater**” will be indicated.

Action:

This alarm will stop chiller operation. Please check following reasons step by step:

Failure	Reason	Corrective

Missing of one phase	a) Power fault b) Phase not connected	a) Check the power supply b) Check if all phases are connected at the corresponding point inside the control cabinet
Bad line voltage	a) Bad line Voltage	a) Please check that the line voltage is within the specified limits
Defective heater	a) Defective heater	a) Replace the heater

Reset of the alarm:

After resolving the problem:

- Reset the motor protection switch in position 1
- Reset by pushing reset button in LaserNet

8.2.5.4 Optic cooling circuit – Over current tank heater

Alarm indication:

Alarm lamp “**Alarms / Overcurrent**” is lighting red. In the page “**Events**” “**Overcurrent of DI water heater**” will be indicated.

Action:

This alarm will stop chiller operation. For possible reasons please see table 8.2.5.3.

Reset of the alarm:

After resolving the problem:

- Reset the motor protection switch in position 1
- Reset by pushing reset button in LaserNet

8.2.5.5 Refrigerant circuit – Over current compressor

Alarm indication:

Alarm lamp “**Alarms / Overcurrent**” is lighting red. In the page “**Events**” “**Overcurrent of compressor**” will be indicated.

Action:

This alarm will stop chiller operation. Please check following reasons step by step:

Failure	Reason	Corrective
Missing phase	a) Power fault b) Phase not connected	a) Check the power supply b) Check if all phases are connected at the corresponding point inside the control cabinet

Incorrect line voltage	Incorrect line Voltage	Please check that the line voltage is within the specified limits
Incorrect line frequency	Incorrect line frequency	Please check that the line frequency is within the specifications
Defective compressor	Defective compressor	Exchange the refrigerant module

Reset of the alarm:

After resolving the problem:

- Reset the motor protection switch in position 1
- Reset by pushing reset button in LaserNet

8.2.5.6 Refrigerant circuit – Over current fan

Alarm indication:

Alarm lamp “**Alarms / Overcurrent**” is lighting red. In the page “**Events**” “**Overcurrent of fan**” will be indicated.

Action:

This alarm will stop chiller operation. For possible reasons please see table 8.2.5.5.

Reset of the alarm:

After resolving the problem:

- Reset the motor protection switch in position 1
- Reset by pushing reset button in LaserNet

8.2.6 SENSOR FAILED ALARM

8.2.6.1 Laser cooling circuit – Error temperature sensor

Alarm indication:

Alarm lamp “**Alarms / Sensor failed**” is lighting red. In the page “**Events**” “**Tap water temperature sensor is defect**” will be indicated.

Action:

This alarm will stop chiller operation. Please check following reasons step by step:

Failure	Reason	Corrective action
Sensor fault	a) Sensor fault	a) Replace the sensor
Bad contact	a) Cable loose	a) Check the terminals for contact

Reset of the alarm:

After solving the problem, you can reset the alarm by pushing the reset button in

LaserNet. The red light will be switched off.

8.2.6.2 Optic cooling circuit – Error temperature sensor

Alarm indication:

Alarm lamp “**Alarms / Sensor failed**” is lighting red. In the page “**Events**” “**DI water temperature sensor is defect**” will be indicated.

Action:

This alarm will stop chiller operation. Please see item 8.2.6.1 and check points given in the table step by step.

Reset of the alarm:

After solving the problem, you can reset the alarm by pushing the reset button in LaserNet. The red light will be switched off.

8.2.6.3 Laser cooling circuit – Error pressure sensor

Alarm indication:

Alarm lamp “**Alarms / Sensor failed**” is lighting red. In the page “**Events**” “**Tap water pressure sensor is defect**” will be indicated.

Action:

This alarm will stop chiller operation. Please check following reasons step by step:

Failure	Reason	Corrective action
Sensor fault	a) Sensor fault	a) Replace the sensor
Bad contact	a) Cable loose	a) Check the terminals for contact
Measurement out of range	a) Pressure to low b) Pressure to high	a) Sensor range -1 to 8 bar. Check why pressure is below -1 bar b) Sensor range -1 to 8 bar. Check why pressure is higher than 8 bar

Reset of the alarm:

After solving the problem, you can reset the alarm by pushing the reset button in LaserNet. The red light will be switched off.

8.2.6.4 Optic cooling circuit – Error pressure sensor

Alarm indication:

Alarm lamp “**Alarms / Sensor failed**” is lighting red. In the page “**Events**” “**DI water pressure sensor is defect**” will be indicated.

Action:

This alarm will stop chiller operation. Please see item 8.2.6.3 and check points given in the table step by step.

Reset of the alarm:

After solving the problem, you can reset the alarm by pushing the reset button in LaserNet. The red light will be switched off.

8.2.6.5 Optic cooling circuit – Error conductivity sensor

Alarm indication:

Alarm lamp “**Alarms / Sensor failed**” is lighting red. In the page “**Events**” “**DI water conductivity sensor is defect**” will be indicated.

Action:

This alarm will not stop chiller operation. Please see item 8.2.6.1 and check points given in the table step by step.

Reset of the alarm:

After solving the problem, you can reset the alarm by pushing the reset button in LaserNet. The red light will be switched off.

8.2.6.6 Refrigerant circuit – Error low pressure sensor

Alarm indication:

Alarm lamp “**Alarms / Sensor failed**” is lighting red. In the page “**Events**” “**Low pressure sensor is defect**” will be indicated.

Action:

This alarm will stop chiller operation. Please check following points step by step:

Failure	Reason	Corrective action
Sensor fault	a) Sensor fault	a) Exchange the sensor
Bad contact	a) Cable loose	a) Check the clamps for contact

Reset of the alarm:

After solving the problem, you can reset the alarm by pushing the reset button in LaserNet. The red light will be switched off.

8.2.6.7 Refrigerant circuit – Error high pressure sensor

Alarm indication:

Alarm lamp “**Alarms / Sensor failed**” is lighting red. In the page “**Events**” “**High pressure sensor is defect**” will be indicated.

Action:

This alarm will stop chiller operation. Please see item 8.2.6.6 and check points given in the table step by step.

Reset of the alarm:

After solving the problem, you can reset the alarm by pushing the reset button in LaserNet. The red light will be switched off.

8.2.7 LOW PRESSURE COMPRESSOR FAULT ALARM

Alarm indication:

Alarm lamp “**Alarms / Sensor failed**” is lighting red. In the page “**Events**” “**Low pressure compressor fault**” will be indicated.

Action:

If the vaporization pressure (LP) is below 2°C there is a danger of refreezing inside the evaporator. Therefore the control will automatically switch off the compressor if a vaporization temperature of less than 2°C is detected for 20 seconds. Please check following points step by step:

Failure	Reason	Corrective action
Tap water flow (laser circuit)	a) To low tap water flow b) No tap water flow	a) Check the water flow. Provide at least a flow of 20 l / min b) The compressor will switch off approximately 15 seconds after starting. Provide at least a water flow of 20 l / min
Tap water temperature to low	a) Tap water temperature lower than 10°C	a) Check tap water temperature inside the tank.
Refrigerant	a) Refrigerant leak	a) See 7.5.5
Condensing pressure	a) Condensing pressure to low	a) Air inlet temperature to low
Expansion valve	a) Expansion valve not working b) Expansion valve defective	a) Heat up the head of the expansion valve with a hot air blower to 40°C. If the evaporating pressure rises, then the valve is good b) If the pressure does not rise, contact our service department

Reset of the alarm:

Reset of this alarm will be possible as soon as the evaporating temperature reached 2°C and the input time delay of the compressor is up.

8.2.8 HIGH PRESSURE COMPRESSOR FAULT ALARM

Alarm indication:

Alarm lamp “**Alarms / Sensor failed**” is lighting red. In the page “**Events**” “**High pressure compressor fault**” will be indicated.

Action:

The maximum operating pressure of the refrigerant circuit is 27 bar. If this pressure is exceeded, the compressor will be stopped. Please check following points step by step:

Failure	Reason	Corrective action
To little air flow	a) Air filter dirty b) Fan defectective	a) See 7.5.4 b) See 8.2.5.6
Air inlet temperature	a) Ambient temperature higher than 40°C	a) Check the installation conditions

Reset of the alarm:

Look for the high pressure switch (see 6.1) and reset the alarm. Then press reset button in LaserNet.

8.2.9 ELECTRIC PHASE CONNECTION WRONG

Alarm indication:

Alarm lamp “**Alarms / Sensor failed**” is lighting red. In the page “**Events**“ “**Electrical phase connection is wrong**” will be indicated.

Action:

If the compressor has been running for 5 seconds and the difference between high and low pressure is less than 4 bars, the mostly reason will be that the rotation direction of the compressor is wrong.

This alarm will stop chiller operation. Please check following points step by step:

Failure	Reason	Corrective action
Phases interchanged	a) The rotation direction of the compressor is wrong	a) In case of wrong rotating, disconnect the chiller via main switch and make sure that nobody can switch on again. The phases L1 and L2 have to be reversed by and by an authorised skilled worker.



DANGER

DANGER:

The electrical connection has to be made by a skilled and authorized worker.

For changing the phases L1 and L2 the chiller has to be disconnected from electric power supply. Make sure that nobody can switch on again.

Reset of the alarm:

After changing the phases L1 and L2, the chiller has to be reconnected to the line

voltage. The chiller control will reboot. Reset of this alarm is not necessary.

8.3 Disruption in operation of the compressor

A qualified person should check the resistance of the motor winding. Please inform our service department if the measured value differs more than 10%. In this case the winding of the motor may be defective. The refrigerant module has to be changed.

8.3.1 Technical data for compressor

Resistance of the winding:	Ω	2,75
Max. operating current:	A	10.1
Sound pressure level:	dB(A)	60 @ 1 m distance

8.3.2 Troubleshooting

Failure	Reason	Corrective action
Motor protection switch disconnected sometimes	a) Setting of the motor protection switch incorrect. b) Power supply voltage sometimes too low or too high	a) See electrical diagram for the current of the motor and make the right setting b) Check power supply voltage
Motor protection switch disconnects immediately as soon as the compressor is switched on	a) Fuses blown b) Cable loose or defective c) Motor winding defective d) Setting of the motor protection switch incorrect	a) Replace fuses b) Check the terminals for contact or exchange cable c) Replace refrigerant module d) See electrical diagram for the current of the motor and correct the setting
The motor did not start even though the motor contactor was switched on	a) Supply voltage not connected b) Fuses blown c) Switching contacts or coil of the contactor defective d) Fuses for control voltage blown e) Motor defective	a) Connect supply voltage b) Replace fuses c) Replace contactor d) Replace fuses e) Replace refrigerant modul.

8.4 Disruption in operation of the pump

A qualified person should check the current of the motor. Please inform our service department if the measured value differs more than 10%. In this case the winding of the motor may be defective and the motor must be changed.

8.4.1 Technical data pump 60 Hz

Maximum operating current:	A	1.8
Max. water flow:	m ³ /h	3.6

8.4.2 Technical data pump 50 HZ

Maximum operating current:	A	1.8
Max. water flow:	m ³ /h	3.0

8.4.3 Troubleshooting

Failure	Reason	Corrective action
See 8.3.2	See 8.3.2	See 8.3.2
Leakage at the shaft seal	a) Shaft seal defective	a) Replace shaft seal

Failure	Reason	Corrective action
Abnormal noise	a) Cavitation	a) Check water level of the tank b) Flow rate too high
Water flow or pressure not stable	a) Suction mesh blocked b) Pump sucks in air c) No water flow also the pump is running d) Air inside the pump e) Pump motor is rotating wrong	a) Clean suction mesh b) Check water level of the tank c) Suction mesh or pump blocked due to contamination. Clean suction mesh or pump. d) Check water level of the tank e) Change rotating direction of the pump
Overload of the motor	a) Flow rate of the pump too high	a) Reduce the flow rate

8.5 Disruption in operation of the fan

A qualified person should check the current of the motor. Please inform our service department if the measured value differs more than 10%. In this case the winding of the motor may be defective and the motor must be changed.





8.5.1 Technical data Fan

Maximum operating current: A 2.85
Maximum operating temperature: °C 60

8.5.2 Troubleshooting

Failure	Reason	Corrective action
Motor protection switch disconnected sometimes	a) Operating temperature of the fan > 60°C b) Operating temperature of the fan > 60°C c) See 8.3.2	a) Ambient temperature > 40°C b) Too little air flow due to polluted air filter c) See 8.3.2

9 ELECTRICAL DRAWING

 WARNING	<p>WARNING: Any work on the chiller may only be performed by qualified personnel. Please contact our service department.</p>
 WARNING	<p>WARNING: The end user has to take care that repairs are done only by qualified personnel.</p>
 WARNING	<p>WARNING: In case of interruption of operation that cannot be solved with the help of this operational manual please disconnect the chiller and contact our service department.</p>
 DANGER	<p>DANGER: Electrical work on the chiller may only be performed by skilled technicians. The electro-technical connections of the chiller must be performed according to and conforming to all relevant VDE, EN and IEC standards. Beyond that, the technical connection requirements of the local authorities must be observed.</p>