



USCGC ALDER (WLB 216)
SPECIFICATION FOR DOCKSIDE REPAIRS
FY2020

Developed By: Pamela E Smith

(REV-2, 15 April 2020)

TABLE OF CONTENTS

Revisions Record.....	iii
Consolidated List of References.....	iv
Consolidated List of Government-furnished Property	viii
Consolidated List of Critical Inspection Items	x
Principal Characteristics	xi
General Requirements	1
WORK ITEM 1: Chain Locker(s), Clean and Inspect	13
WORK ITEM 2: Tanks (MP Fuel Service), Clean and Inspect	15
WORK ITEM 3: Tanks (Potable Water), Clean and Inspect	19
WORK ITEM 4: Tanks (Lube Oil), Clean and Inspect.....	23
WORK ITEM 5: Main Diesel Engine (MDE) Exhaust Piping, Commercial Clean	26
WORK ITEM 6: Ship Service Diesel Generator (SSDG) Exhaust Piping, Commercial Clean.....	29
WORK ITEM 7: Hydraulic Inhaul Winch, Inspect And Service.....	32
WORK ITEM 8: Anchor Windlass, Inspect and Service	41
WORK ITEM 9: Twin Pivot Arm Davit, Inspect and Service.....	44
WORK ITEM 10: SSDG Isolation Mount, Renew	48
WORK ITEM 11: Deck Covering, Electrical Matting, Renew	71
WORK ITEM 12: Potable Water Pipe, Renew	73
WORK ITEM 13: Potable Water Valves, Renew	76
WORK ITEM 14: Steering Hydraulic Pipe Hanger Repair	79
WORK ITEM 15: Fire Pump Discharge Piping, Renew.....	84
WORK ITEM 16: LO Tank Vent Repair	87
WORK ITEM 17: Chain Washdown Coupling, Install.....	90
WORK ITEM 18: Main Diesel Engine, Vulkan Coupling Renew	92
WORK ITEM 19: Ship Service Diesel Generator, Clean & Inspect.....	97
WORK ITEM 20: Component, Work Description.....	101
WORK ITEM 21: Molded Case Circuit Breakers, Inspect & Test	112
WORK ITEM 22: Hull Fittings (Weight Handling Rigging Hardware), Inspect and Test.....	120
WORK ITEM 23: Sewage Holding Tank(s), Clean and Inspect.....	125
WORK ITEM 24: COVID-19 Prevention and Response Planning and Precautions, Perform	128

REVISIONS RECORD

This page is used to record specification revisions, which may have occurred subsequent to a Revision 0 (Rev-0) package. Information listed is intended to provide contractors and field unit personnel a means to ensure all the current specification revision pages are present when reviewing or utilizing this specification package.

DATE	REV#	WORK ITEM#	CHANGES MADE
08 Apr 2020	1	8	Pg 42, Task 3.2, #3 change Task Type from <<gearbox task>> to Disassemble and Inspect
15 Apr 2020	2	24	Add WI #24 COVID-19 Prevention and Response Planning and Precautions, Perform

NOTE : All work item and paragraph numbers listed above for a given revision correspond to same numbers in the previous revision. This revised specification is self-contained with all of the above listed changes incorporated.

CONSOLIDATED LIST OF REFERENCES

The below-listed documents form a part of this specification to the extent specified herein. Approval/publication dates or revision dates/numbers are also identified, to ensure that same document versions are used at the time of specification writing and during contract execution.

All Coast guard drawings, technical publications, and standard specifications will be provided to contractors by the Coast Guard at an appropriate time, or upon request, free of charge. Other Government documents may be accessed – free of charge – from links located on the SFLC website. Commercial sites provide access to their respective documents.

COAST GUARD DRAWINGS

Coast Guard Drawing 225-WLB-070-001, Rev G, Fire, Watertight Integrity & Hazardous Locations Plan
Coast Guard Drawing 225 WLB 581-001, Rev E, Anchor Handling System Arrangement
Coast Guard Drawing 225 WLB 801-020, Rev B, Tank CAPACITY - 95% Curves
Coast Guard Drawing 225B WLB 541-007, Rev D; Incinerator Fuel Oil Service Tank
Coast Guard Drawing 225B WLB 573-001, Rev E, Buoy Handling System Arrangement
Coast Guard Drawing 225B WLB 259-001, Rev C, Combustion Intake & Exhaust Diagram
Coast Guard Drawing 225B WLB 259-005, Rev C, Combustion Intake & Exhaust A&D Hull Block 940
Coast Guard Drawing 225B WLB 259-006, Rev C, Combustion Intake & Exhaust A&D Hull Blocks 970 & 975
Coast Guard Drawing 225B WLB 541-001, Rev G; Fuel Oil System Diagram
Coast Guard Drawing 225B WLB 549-001, Rev A, Onboard Lubrication Requirements
Coast Guard Drawing 225B WLB 556-001, Rev F, Hydraulic System Diagram
Coast Guard Drawing 225B WLB 573-002, Rev -, Weight Handling System Arrangement
Coast Guard Drawing 225B WLB 573-11, Rev -, ATON Tie Downs
Coast Guard Drawing 225B WLB 581-001, Rev C, Anchor Handling System Arrangement
Coast Guard Drawing 225B WLB 581-001, Rev D, Anchor Handling System Arrangement
Coast Guard Drawing 225B WLB 593-001, Rev D, Sewage and Waste Water System Diagram
Coast Guard Drawing 225B WLB 593-009, Rev B, Sewage Holding Tank
Coast Guard Drawing 225B WLB 601-001, Rev F, General Arrangement Inboard & Outboard Profiles
Coast Guard Drawing 225B WLB 601-002, Rev H, Booklet of General Drawings
Coast Guard Drawing 225B WLB 672-001, Rev C, Storerooms, Cargo Stowage and Ship Store Arrangement and Details
Coast Guard Drawing 225B WLB 801-005, Rev A Tank CAPACITY - 95% Curves
Coast Guard Drawing 225B-WLB 521-1, Rev -, Fire-main System Diagram
Coast Guard Drawing 225B-WLB 521-6, Rev -, Fire-main System A/D, FR 66 Aft, Block 940,950
Coast Guard Drawing 225B-WLB 532-2, Rev E, Potable Water System Diagram
Coast Guard Drawing 225B-WLB 180-10, Rev -, Generator Foundations
Coast Guard Drawing 225B-WLB 201-2, Rev C, Access Removal Routes
Coast Guard Drawing 225B-WLB 233-1, Rev D, Propulsion Train Installation Drawing

USCGC ALDER (WLB-225B) DOCKSIDE AVAILABILITY FY2020

Coast Guard Drawing 225B-WLB 256-7, Rev -, Heat Exchanger Modifications for CAT 3508 SSDG
Coast Guard Drawing 225B-WLB 320-1, Rev AC, Electrical One Line Diagram
Coast Guard Drawing 225B-WLB 505-1, Rev D, General Requirements For Piping Systems
Coast Guard Drawing 225B-WLB 506-1, Rev G, Overflows, Air Escapes And Sounding Tubes Diagram
Coast Guard Drawing 225B-WLB 506-9, Rev -, MMA Overflows, Air Escapes & Sndg Tubes Diag
Coast Guard Drawing 225B-WLB 561-4, Rev E, Steering Components Arrangement and Detail
Coast Guard Drawing 225B-WLB 601-1, Rev J, General Arrangements, Inboard and Outboard Profiles
Coast Guard Drawing FL 7101-573, Rev L, Buoy Chain Winch Assy Model CW1

COAST GUARD PUBLICATIONS

Coast Guard Technical Publication (TP) 3762, 15-OCT-04, Dual Point Davit - ATON Workboat - Model TWPIV5-0A 5
Coast Guard Commandant Instruction(COMDTINS) M10360.3 (series), Coatings and Color Manual
Coast Guard Technical Publication (TP) 3498, Section A, Jul 2015, Buoy Chain Winch
Coast Guard Technical Publication (TP) 3518B, 07-MAY-01, Main Diesel Engine (MDE) - Model 3608/1
Coast Guard Technical Publication (TP) 3523B, May 2001; Coupling, Torsional (Flexible),
Manufacturer: American Vulkan, Model NO. RATO-S 3321-2100/1070 (Rev B)
Coast Guard Technical Publication (TP) 3536, Jul 2003, Switchboard, Main, Emergency, and Thruster
Coast Guard Technical Publication (TP) 3537A, 07-MAY-01, Ship's Service Diesel Generator Set (SSDG) - Model 3508
Coast Guard Technical Publication (TP) 3537B, Manufacturer's Instruction Book – SWBS Group(s) 310
Coast Guard Technical Publication (TP) 3559, SWBS 581B, Anchor Windlass, P/S - Model BMD-478
Surface Forces Logistics Center Standard Specification (SFLC Std Spec) 0000, 2018, General Requirements
Surface Forces Logistics Center Standard Specification (SFLC Std Spec) 0450, 2018, Electrical Power for Contractor's Tools & Equipment
Surface Forces Logistics Center Standard Specification (SFLC Std Spec) 3042, 2018, Shipboard Electrical Cable Removal, Relocation, Splice, Repair, and Installation
Surface Forces Logistics Center Standard Specification (SFLC Std Spec) 3100, 2018, Inspect, Test and Recondition AC Synchronous Machines In-Place
Surface Forces Logistics Center Standard Specification 0740 (SFLC Std Spec 0740), 2018, Welding and Allied Processes
Surface Forces Logistics Center Standard Specification 3020 (SFLC Std Spec 3020), 2018, Overhaul AC Electrical Motors
Surface Forces Logistics Center Standard Specification 5000 (SFLC Std Spec 5000) 2018, Auxiliary Machine Systems
Surface Forces Logistics Center Standard Specification 6310 (SFLC Std Spec 6310), 2018, Requirements for Preservation of Ship Structures
Surface Forces Logistics Center Standard Specification 6341 (SFLC Std Spec 6341), 2018, Install Interior Deck Covering Systems
Surface Forces Logistics Center Standard Specification 8636 (SFLC Std Spec 8636), 2018, Temporary Hull Accesses
Welding and Allied Processes

OTHER REFERENCES

- American National Standards Institute (ANSI/EASA) AR100, 2015, Recommended Practice for the Repair of Rotating Electrical Apparatus
- American National Standards Institute/American Water Works Association (ANSI/AWWA) C652, 2011, Disinfection of Water-Storage Facilities
- American National Standards Institute/National Electrical Manufacturers Association (ANSI/NEMA) AB 4, Mar 2011, Guidelines for Inspection and Preventive Maintenance of Molded Case Circuit Breakers Used in Commercial and Industrial Applications
- American National Standards Institute/NSF International (ANSI/NSF) 61, 2015, Drinking Water System Components - Health Effects
- American National Standards Institute/Underwriters Laboratories Inc. (ANSI/UL) 489, Molded Case Circuit Breakers, Molded-Case Switches and Circuit-Breaker Enclosures, Jan 2013
- ASTM International (ASTM) D1330, 2015, Standard Specification for Rubber Sheet Gaskets
- ASTM International (ASTM) D5363, 2008, Standard Specification for Anaerobic Single Component Adhesives (AN)
- Chockfast® Orange, or equivalent, general Guidelines for Marine Chock Designers Bulletin No. 692D
- Christie & Grey Data Sheet DS 094 - Instructions for the measurement of mounting heights using either spring loaded telescopic gauges or a digital DTI set
- Christie & Grey Data Sheet DS 096 - Mount Height Data Collection Sheet For New Installations and In Service Maintenance Checks - Marine Diesel Engines
- Christie & Grey Drawing No. 44560 Isolation of Caterpillar 3508 Generator Set
- Code of Federal Regulations (CFR) Title 29, Part 1915, 2014, Occupational Safety and Health Standards for Shipyard Employment
- Code of Federal Regulations (CFR) Title 29, Part 1910, Jul 2019, Occupational Safety and Health Standards
- Federal Specification (Fed Spec) DDD-C-95, Mar 1972, Carpets and Rugs, Wool, Nylon, Acrylic, Modacrylic
- Manufacturers Standardization Society of the Valve and Fittings Industry (MSS), SP-58, 2009, Pipe Hangers and Supports – Materials, Design, Manufacture, Selection, Application and Installation
- MIL-DTL-1222, Dec 2000, Studs, Bolts, Screws and Nuts for Applications Where a High Degree of Reliability Is Required
- MIL-PRF-24176 , Oct 2004, Cement, Epoxy, Metal Repair And Hull Smoothing (Metric)
- MIL-S-45180, 1998; Sealing Compound, Gasket, Hydrocarbon Fluid and Water Resistant
- Society of Automotive Engineers (SAE) Aerospace Material Specification (AMS) C6183, 2013, Cork and Rubber Composition Sheet; for Aromatic Fuel and Oil Resistant Gaskets
- Society of Automotive Engineers (SAE) Aerospace Material Specification (AMS) C6183, 2013, Cork and Rubber Composition Sheet; For Aromatic Fuel and Oil Resistant Gaskets
- The Society for Protective Coatings (SSPC) Paint Application Specification No. 3 (SSPC-PA Guide 3), 1995, A Guide to Safety in Paint Application
- The Society for Protective Coatings (SSPC) Surface Preparation Specification No.1 (SSPC-SP 1), 2004, Solvent Cleaning
- The Society for Protective Coatings (SSPC) Surface Preparation Specification No.11 (SSPC-SP 11), 2004, Power Tool Cleaning to Bare Metal
- The Society for Protective Coatings (SSPC)/NACE International (NACE) Joint Surface Preparation Standard SSPC-SP 10/NACE No.2, 2007, Near-White Blast Cleaning

USCGC ALDER (WLB-225B) DOCKSIDE AVAILABILITY FY2020

Underwriters Laboratories Inc. (UL) 1066, Low-Voltage AC and DC Power Circuit Breakers Used in Enclosures, Apr 2012

CAT Alignment Application and Installation Guide, 2012 caterpillar

CONSOLIDATED LIST OF GOVERNMENT-FURNISHED PROPERTY

The following is a list of property, which the Government will furnish. This list supersedes any other material obligations indicated or implied by referenced drawings.

WORK ITEM	MTI	ITEM DESCRIPTION	NSN/PN	QTY	ESTIMATED COST (\$/UNIT)
7	N	Roller bearing Unit	NSN: 3130-01-504-4363	2 ea.	4,012.00
7	N	Grease seal	NSN: 5330-01-462-5544	4 ea.	79.25
7	N	Level wind pivot bushing	NSN: 3120-01-621-2293	1 ea.	1,139.00
7	N	Level wind thrust bearing	NSN: 3120-01-621-2300	2 ea.	483.30
7	N	Rexroth DCV	NSN: 4810-01-507-0037	1 ea.	208.29
7	N	Rexroth Sandwich Flow Control	NSN: 4810-01-505-9289	1 ea.	250.00
7	N	Sun Sandwich Relief Valves	NSN: 4820-01-439-2451	2 ea.	900.00
7	Y	Level Wind Hydraulic Cylinder	NSN: 3040-01-441-3721	1 ea.	7,423.00
7	N	3:1 Pilot Ratio, Vented Counterbalance Valve Assembly	NSN: 4820-01-563-5841	1 ea	98.70
7	N	Fully Adjustable Needle Valve	NSN: 4820-01-416-0579	1 ea	48.75
7	N	Wire Rope Assembly	NSN: 4010-01-646-6972	1 ea.	500.00
7	Y	**Hydraulic Motor	NSN: 4320-01-445-2248	1 ea	23,998
7	N	**Pump, Hydraulic Ram, Hand Driven	NSN: 4320-01-286-4065	1 ea.	419.77
7	N	**Cylinder Pin	NSN: 5315-01-515-9847	1 ea	500.00
7	N	**Cylinder Pin	NSN: 5315-01-515-9912	1 ea	520.00
9	N	Wire Rope Renewal Kit	NSN: 3950-01-F13-3314 PN: 892-02060	1 ea.	5,302.00
9	N	Check Winch Gearbox Oil Kit	NSN: 5330-01-F13-3315 PN: 892-02061	1 ea.	64.00
9	N	Hydraulic Fluid Filter Renewal Kit	NSN: 3950-01-F13-3316 PN: 892-02063	1 ea.	2,108.00
9	N	Main Winch Brake and Centrifugal Brake Inspection Kit	NSN: 3950-01-F13-3299 PN: 892-02064	1 ea.	908.00
9	N	Hydraulic Breather Replacement Kit	NSN: 4310-01-F13-3300 PN: 892-02065	1 ea.	228.00
9	N	Hydraulic Hose Replacement Kit	NSN: 4720-99-553-9143 PN: 892-02066	1 ea.	1,600.00
10	N	Christie & Grey Isolation Mount T2.S20.45.C0.100 TSC T2 20/45 (UTS threads)	NSN: 5340-99-613-8406	8 ea.	558

USCGC ALDER (WLB-225B) DOCKSIDE AVAILABILITY FY2020

10	N	Christie & Grey Isolation Mount T2.S20.55.C0.100 TSC T2 20/55 (UTS threads)	NSN: 5340-99-501-0478	4 ea.	558
10	N	Christie & Grey Sole Plate54378 rev A	NSN: 5340-99-387-2519	12 ea.	98
18	N	***Vulkan RATO Flexible Coupling Element	PN: 1G33214105 NSN: 3010- 01-494-1016	1.ea.	60,537.00

*Government-loaned property, which shall be returned to the vessel upon completion of the availability.

**New or refurbished equipment that the Government may provide for installation in place of existing equipment.

***Government-furnished property, which is to be supplied by either the vessel or the C4IT ServiceCenter

CONSOLIDATED LIST OF CRITICAL INSPECTION ITEMS

The following is a list of work items, which contain Critical Inspection reports, which the Contractor must complete within the first 25% of the availability contract period (see SFLC Std Spec 0000, paragraph 3.2.6.5 (Inspection report particulars)):

Work Item	Title
2	Tanks (MP Fuel Service), Clean and Inspect
7	Hydraulic Inhaul Winch, Inspect And Service
8	Anchor Windlass, Inspect and Service
9	Twin Pivot Arm Davit, Inspect and Service
11	Deck Covering, Electrical Matting, Renew
19	Ship Service Diesel Generator, Clean & Inspect
20	Component, Work Description
21	Molded Case Circuit Breakers, Inspect & Test

USCGC ALDER (WLB-225B) DOCKSIDE AVAILABILITY FY2020

PRINCIPAL CHARACTERISTICS

225' WLB (B-CLASS)	
PHYSICAL	
Length overall	225' 0"
Length between perpendiculars	206' 0"
Maximum beam	46'
Designed draft	13' 0"
Full load displacement	1905.6 Long Tons SW
Light ship displacement	1500.7 Long Tons SW
Minimum operating displacement	1869.2 Long Tons SW
Mast height (above 12' waterline)	67' 5"
Anchor	Two 4000 lb standard Navy stockless anchors, 8 shots each, port and starboard, 1-3/8 die lock chain
HULL	
Bilge keels (port & starboard)	Frames 42-79
Frame spacing	
FR 0 to 12	21"
FR 12 to 30	22"
FR 30 to 102	24"
MACHINERY	
Main propulsion	Diesel Reduction
Diesel engines	Two Caterpillar 3608, TA, 3100 BHP each @ 900 RPM
Number of propellers	1
Number of blades	4
Diameter	10'
Pitch	Controllable
RPM	254
Ship's service diesel generators	Two Caterpillar 3508 TA, 450 KW
Emergency diesel generator	One Caterpillar 3406 DITA, 280 KW
Shore tie	Two 450 VAC, 400 Amp, 3-wire
Shaft bearing, forward	Cooper Bearing 01-BCP-1400-EX-TL
Shaft bearing, aft	Water Lubricated Cutless Bearing
TANK CAPACITIES	
Diesel oil	76,498 gal.
Fresh water capacity	8056 gal.
Hydraulic oil capacity	2785 gal.
Lube oil storage	764 gal.
Grey water tank	2700 gal.
Sewage holding tank	1700 gal.

General Requirements

1. SCOPE

1.1 Intent. This standard specification invokes general requirements for conducting vessel repairs performed by commercial contractors at a Coast Guard facility for Coast Guard vessels.

1.2 Term interchangeability. The terms 'Contractor', 'CG Yard', 'NAVSTA EVERETT', 'shipyard', 'Base', and 'Coast Guard Industrial' are used interchangeably in this specification. Where the primary service provider is Coast Guard personnel, references to contractor and other noted descriptors within this specification or within drawings, publications, SFLC Standard Specifications or other commercial and military references are deemed the same as prime service provider.

2. REFERENCES

COAST GUARD DRAWINGS

None

COAST GUARD PUBLICATIONS

Coast Guard Commandant Instruction (COMDTINS) M10360.3 (series), Coatings and Color Manual
Surface Forces Logistics Center Standard Specification 0000 (SFLC Std Spec 0000), 2018, General Requirements

Surface Forces Logistics Center Standard Specification 0740 (SFLC Std Spec 0740), 2018, Welding and Allied Processes

Surface Forces Logistics Center Standard Specification 6310 (SFLC Std Spec 6310), 2018, Requirements for Preservation of Ship Structures

OTHER REFERENCES

None

3. REQUIREMENTS

3.1 General. The Contractor shall conform to all requirements specified in SFLC Std Spec 0000 and in this item, as applicable, during the performance of this availability.

NOTE

The requirements of paragraph 3.1 (General) applies to all work under the scope of this contract, whether explicitly stated in work items or not, and to all other work subsequently authorized by changes, modifications, or extensions to the contract.

USCGC ALDER (WLB-225B) DOCKSIDE AVAILABILITY FY2020

3.2 Fire watch requirements. The Contractor shall refer to 3.3.1.3 (Fire watch requirements) of SFLC Std Spec 0000, in accomplishing the following task:

- Provide portable fire extinguishers for Coast Guard fire watch personnel. Coast Guard fire watch is in lieu of contractor personnel during the hours of 0800-1600, Monday through Friday, and limited to two Coast Guard fire watch personnel.
- Provide fire watch personnel and fire extinguishers for the duration of the availability period, during and beyond noted Coast Guard fire watch support.

3.3 Preservation requirements. The Contractor shall accomplish all preservation tasks, including touch-ups, in accordance with SFLC Std Spec 6310.

3.3.1 Brand name approval. Ensure that all contractor-furnished coatings are in accordance with SFLC Std Spec 6310, Appendix C (Authorized Coatings for Use on Cutters and Boats).

3.3.2 Coating colors and system color schemes. Ensure that all colors and color coat/paint schemes are in accordance with COMDTINST M10360.3, Chapter 6 (Cutter and Boat Colors Exterior and Interior).

NOTE

Unless a waiver has been granted (in writing) by the KO, deviations from authorized coatings (listed in Appendix C of SFLC Std Spec 6310) and colors and color schemes (provided in Chapter 6 of COMDTINST M10360.3) are strictly prohibited.

3.4 Welding and brazing requirements. The Contractor shall perform all welding and allied processes, and NDE in accordance with SFLC Std Spec 0740.

3.5 Environmental protection requirements. The Contractor shall adhere to the following environmental protection requirements in accordance with the SFLC Stand Spec 0000:

3.5.1 USCG facilities. The Contractor shall provide and maintain environmental protection as defined in SFLC Std Spec 0000 Appendix B, Requirements for Environmental Protection at USCG Facilities, during the performance of this availability. Contractor shall plan for and provide environmental protective measures to control pollution that develops during normal practice, as well as plan for and provide environmental protective measures required to correct conditions that develop during the project. Contractor shall comply with applicable Federal, state, and local laws, codes, ordinances, and regulations in their entirety. Any reference to a specific portion of a Federal, state, or local law, code, ordinance, or regulation in this or any other item shall not be construed to mean that relief is provided from any other sections of the law, code, ordinance, or regulation.

3.5.1.1 USCG Generator status. The activity Generator Status for the Coast Guard Facility is medium.

3.5.1.2 Plans and permits. The CG Facility has unit specific permits including the following:

- Spill Prevention Control and Countermeasures (SPCC) Plan: Unit has a SPCC Plan which requires certain unit-specific procedures be followed for the storage, inspection, and transfer of petroleum products in containers 55 gallons or greater.
- National Pollutant Discharge Elimination System (NPDES) Storm Water (SW) Permit: Unit has an NPDES SW permit which requires unit-specific procedures be followed for the storage and inspection of equipment and materials which may contribute contaminants to storm water discharges.
- Air Emission Permit: Unit has a Air Emission Permit which requires unit-specific procedures be followed for the emissions of VOCs and hazardous air pollutants.

USCGC ALDER (WLB-225B) DOCKSIDE AVAILABILITY FY2020

3.5.2 Test and procedures. The Contractor shall be required to promptly conduct tests and procedures for the purpose of assessing whether operations are in compliance with applicable Environmental Laws. Analytical work shall be done by qualified laboratories; and where required by law, the laboratories shall be certified.

3.5.3 Regulatory notifications. The Contractor shall be responsible for all regulatory notification requirements in accordance with Federal, State and local regulations. In cases where the Coast Guard must also provide public notification, such as storm water permitting, the Contractor must coordinate with the Contracting Officer or COR, and if work is being performed at a USCG Facility, the local Facility Engineer or Engineering Officer. The Contractor shall submit copies of all regulatory notifications to the Contracting Officer and the local Facility Engineer or Engineering Officer prior to commencement of work activities. Regulatory notifications shall be provided for including but not limited to demolition, renovation, National Pollutant Discharge Elimination System (NPDES) defined site work, and remediation of controlled substances such as asbestos, hazardous waste, and lead paint.

3.5.4 Environmental manager. The Contractor shall appoint in writing an Environmental Manager for the project, and shall be responsible for coordinating Contractor compliance with Federal, State, local, and station environmental requirements. The Environmental Manager shall ensure compliance with Hazardous Waste Program requirements, including hazardous waste handling, storage, manifesting, and disposal; implement the Contractors' Environmental Management Plan; ensure that all environmental permits are obtained, maintained, and closed out; ensure compliance with Storm Water Program Management requirements; ensure compliance with Hazardous Materials including storage, handling, and reporting requirements; as well as coordinate any remediation of regulated substances such as lead, asbestos, and polychlorinated biphenyl (PCB). This may be a collateral position; however the individual must be trained to accomplish the following duties; ensure waste segregation and storage compatibility requirements are met; inspect and manage Satellite Accumulation areas; ensure only authorized personnel add wastes to containers; ensure all Contractor personnel are trained in 40 CFR requirements and individual position requirements; coordinate removal of waste containers; and maintain the Environmental Records binder and required documentation, including environmental permits compliance and close-out.

3.5.5 HW disposal. Contractor shall comply with SFLC Std Spec 0000 Appendix B, Requirements For Environmental Protection At USCG Facilities for HW disposal, and ensure that waste removals are conducted during normal business hours (0800-1600) on Monday through Friday (excluding holidays).

3.5.6 Additional Requirements. The Contractor shall be aware of the following:

3.5.6.1 No Contractor or Subcontractor shall have the authority to sign a Hazardous Waste Manifest using the Coast Guard facility's EPA Generator ID Number or remove contract generated hazardous waste from the Coast Guard facility without COR or KO-approval.

3.5.6.2 Local environmental regulations at the Government facilities may be more stringent. As with all environmental regulations, the Contractor shall prepare for and comply with local and state regulations.

3.5.6.3 Coast Guard facilities do not maintain Facilities Response Plans (FRPs) per 33 CFR 154. Contractor shall furnish the FRP when required for over-the-water liquids transfers to and from vessels, and is required for oil/fuel transfers to/from vessels for 250 barrels (10,500 gallons) or more.

3.6 Local Policy. None.

3.7 SFLC standard specification approved changes. The Contractor shall be aware that the following are approved changes to published SFLC 2014 Edition Standard Specifications and supersede published content:

USCGC ALDER (WLB-225B) DOCKSIDE AVAILABILITY FY2020

3.7.1 Change to SFLC Std Spec 0000, paragraph 1.3. 'Acronyms and term definitions', page 5, "PCL (Paint Containing Lead)" definition replaced by, "Any paint or coating containing lead in excess of 0.009 percent by weight (1.0 mg/cm² or 90 ppm). Lead Based Paint (LBP) is an interchangeable term with PCL."

3.7.1.1 Change Std Spec 0000 paragraph 3.2.4.2.3(QP 1 inspector or tech rep duties) bullet, "Determine when applied coats have sufficiently cured for overcoating or for system service resumption (see paragraph 3.1.19 of SFLC Std Spec 6310 (Critical drying time requirements))." to "Determine when applied coats have sufficiently cured for overcoating or for system service resumption (see paragraph 3.1.17 of SFLC Std Spec 6310 (Critical drying time requirements))."

3.7.2 Change to Std Spec 5000, paragraph D2.2.1.1 bullet, "For running rigging, furnish class 6x37, uncoated, independent wire rope core (IWRC), right regular lay (RRL) wire rope or Dyform-18, rotation resistant wire rope," to "For running rigging, furnish class 6x36, uncoated, independent wire rope core (IWRC), right regular lay (RRL) wire rope or Dyform-18, rotation resistant wire rope."

3.7.2.1 Change to Std Spec 5000, page D-2, Table D-1 title from "DYFORM-18, 6X19 AND 6X37 IWRC RRL," to "DYFORM-18, 6X19 AND 6X36 IWRC RRL"

4. NOTES

4.1 QA inspection forms. QA inspection forms (QA-1 thru QA-5), required in SFLC Std Spec 6310 to be completed and submitted during preservation of "critical-coated surfaces", are provided at the end of this document.

USCGC ALDER (WLB-225B) DOCKSIDE AVAILABILITY FY2020

**QA-1 - QUALITY ASSURANCE INSPECTION FORM
(PRESERVATION CHECKLIST)**

VESSEL NAME	HULL #	WORK ITEM #	WORK ITEM TITLE
LOCATION OF WORK (INCL. FRAME #'S)			AREA (SQFT)

CHECKPOINT 1 – COATING SYSTEM COMPLIANCE			
	Ensure all coatings are in compliance with SFLC Std Spec 6310, Appendix C.		
CHECKPOINT 2 - PAINT STORAGE			
	Ensure all coatings are kept at a temperature of 65 to 85°F at all times, unless otherwise specified by the coating mfg.		
CHECKPOINT 3 - AMBIENT CONDITIONS			
	Ensure surface and surrounding temperatures are each between 50 and 90°F for water-containing coatings, and 35 and 95°F for other coatings, unless otherwise specified by the coating manufacturer(s).		
	Ensure maximum relative humidity (RH) is as follows, from surface preparations through final curing of topcoat: 50% for tanks, voids, and vent plenum; and 85% for all other areas, unless otherwise specified by manufacturer(s).		
	Ensure surface temperature is at least 5°F above the dew point, unless otherwise specified by the coating mfg.		
CHECKPOINT 4 - PRE-SURFACE PREPARATION			
	Remove surface contaminants (soluble salts, loose rust, mud, and marine growth) with low pressure fresh water wash down (maximum 5,000 psi). If oil and grease are present, perform solvent cleaning, as per SSPC SP-1.		
	Verify equipment setup, blast media, and surface preparation methods match designated test coupon.		
CHECKPOINT 5 - SURFACE PREPARATION			
	Verify environmental conditions (see CHECKPOINT 3).		
	Ensure cleanliness of prepared surface is as per specification (i.e.: SSPC SP-11, SP-10, SP WJ-2...).		
	Verify surface anchor profile using ASTM D4417-Methods B or C against SFLC Std Spec 6310. Conduct profile readings at a minimum of 5 locations for the first 1000-sqft area, and 2 locations for each succeeding 1000-sqft area.		
	Measure soluble salt conductivity in accordance with SSPC-Guide 15. Conduct 5 measurements per each 1000-sqft area (max. threshold: 70 microsiemens/cm for non-submerged surfaces, 30 microsiemens/cm for submerged surfaces).		
CHECKPOINT 6 - PRIMER COAT APPLICATION			
	Verify environmental conditions (see CHECKPOINT 3).		
	Verify proper mixing and stand-in (induction) times.		
	Ensure no paint is applied when the temperature is expected to drop to freezing before the paint has dried.		
	Ensure surfaces are completely dry, unless otherwise allowed by the coating manufacturer(s).		
	Verify wet film thickness (WFT) at random, to prevent under or over application. Verify final DFT.		
	Brush out all runs, sags, drips, and puddles.		
	Perform visual inspection for holidays and other defects.		
CHECKPOINT 7 – STRIPE COAT APPLICATION			
	Verify environmental conditions (see CHECKPOINT 3).		
	Ensure overcoating window is as per manufacturer’s instructions.		
	After primer coat (mist coat after inorganic zinc), brush-apply un-thinned coat of same primer paint over edges, weld seams, cut-outs, and areas of complex geometries @ 3-4 mils wet film thickness (WFT).		
CHECKPOINT 8 – TOP COAT APPLICATION			
	Verify environmental conditions (see CHECKPOINT 3).		
	Ensure overcoating window is as per manufacturer’s instructions.		
	Verify proper mixing and stand-in (induction) times, as applicable.		
	Verify wet film thickness at random, to prevent under or over application.		
	Brush out all runs, sags, drips, and puddles.		
CHECKPOINT 9 – FINAL INSPECTION			
	Verify final system dry film thickness. Conduct 5 sets of 3 readings for each of the first 3 100-sqft areas, followed by 5 sets of 3 readings for each succeeding 1000-sqft area.		
	Ensure that system cure is in accordance with manufacturer's recommendation for intended service.		
	Ensure potable water tank exhaust ventilation is maintained continuously from and during coating application through final system cure, to exhaust all solvent to the atmosphere and to prevent solvent entrapment.		
	For immersion coatings (including tank U/W body), record date and time of the following events: Final coat application: / ; Return to service or removal from environment controls: /		
CHECKPOINT 10 – RECORD KEEPING			
	Complete, sign, and submit all provided QA Inspection Forms.		
NAME OF QP-1/NACE INSPECTOR	SIGNATURE	CERT. #	DATE / TIME

USCGC ALDER (WLB-225B) DOCKSIDE AVAILABILITY FY2020
QA-3a - QUALITY ASSURANCE INSPECTION FORM
(SURFACE PROFILE LOG FOR PROFILE MEASUREMENTS IAW ASTM D4417-METHOD-C)

VESSEL NAME	HULL #	WORK ITEM #	WORK ITEM TITLE
LOCATION OF WORK (INCL. FRAME #'S)			AREA (SQFT)

SURFACE PREPARATION METHOD		PROFILE ACHIEVED (MILS)		
		MIN	MAX	MEAN
SSPC-SP-10/NACE No. 2	<input type="checkbox"/>			
SSPC-SP WJ-1/NACE WJ-1	<input type="checkbox"/>			
SSPC-SP WJ-2/NACE WJ-2	<input type="checkbox"/>			
SSPC-SP WJ-3/NACE WJ-3	<input type="checkbox"/>			
SSPC-SP WJ-4/NACE WJ-4	<input type="checkbox"/>			
SSPC-SP-3	<input type="checkbox"/>			
SSPC-SP-11	<input type="checkbox"/>			
SSPC-SP-11 (inaccessible area)	<input type="checkbox"/>			
Brush-blasting (non-metallic substrate)	<input type="checkbox"/>			
ABRASIVE MANUFACTURER:		ABRASIVE SIEVE SIZE:		

PLACE SURFACE PROFILE REPLICA TAPES IN THE SPACES PROVIDED BELOW, TO SERVE AS PERMANENT QA RECORD. MAINTAIN A SEPARATE LOG FOR EACH LOCATION. WHEN AN AREA IS DIVIDED INTO SEPARATE SECTIONS, MAINTAIN A SEPARATE LOG FOR EACH SECTION.					
Place Surface Profile Replica Tape Here		Place Surface Profile Replica Tape Here		Place Surface Profile Replica Tape Here	
Reading (mils):		Reading (mils):		Reading (mils):	
Place Surface Profile Replica Tape Here		Place Surface Profile Replica Tape Here		Place Surface Profile Replica Tape Here	
Reading (mils):		Reading (mils):		Reading (mils):	
Place Surface Profile Replica Tape Here		Place Surface Profile Replica Tape Here		Place Surface Profile Replica Tape Here	
Reading (mils):		Reading (mils):		Reading (mils):	
Place Surface Profile Replica Tape Here		Place Surface Profile Replica Tape Here		Place Surface Profile Replica Tape Here	
Reading (mils):		Reading (mils):		Reading (mils):	
Place Surface Profile Replica Tape Here		Place Surface Profile Replica Tape Here		Place Surface Profile Replica Tape Here	
Reading (mils):		Reading (mils):		Reading (mils):	
MEAN MIL READING (IAW ASTM D4417-METHOD C) FOR ABOVE 15 READINGS:					

NAME OF QP-1/NACE INSPECTOR	SIGNATURE	CERT. #	DATE /
-----------------------------	-----------	---------	--------

USCGC ALDER (WLB-225B) DOCKSIDE AVAILABILITY FY2020

			TIME

USCGC ALDER (WLB-225B) DOCKSIDE AVAILABILITY FY2020
QA-3b - QUALITY ASSURANCE INSPECTION FORM
(SURFACE PROFILE LOG FOR PROFILE MEASUREMENTS IAW ASTM D4417-METHOD-B)

VESSEL NAME	HULL #	WORK ITEM #	WORK ITEM TITLE
LOCATION OF WORK (INCL. FRAME #'S)			AREA (SQFT)

SURFACE PREPARATION METHOD		PROFILE ACHIEVED (MILS)		
		MIN	MAX	MEAN
SSPC-SP-10/NACE No. 2	<input type="checkbox"/>			
SSPC-SP WJ-1/NACE WJ-1	<input type="checkbox"/>			
SSPC-SP WJ-2/NACE WJ-2	<input type="checkbox"/>			
SSPC-SP WJ-3/NACE WJ-3	<input type="checkbox"/>			
SSPC-SP WJ-4/NACE WJ-4	<input type="checkbox"/>			
SSPC-SP-3	<input type="checkbox"/>			
SSPC-SP-11	<input type="checkbox"/>			
SSPC-SP-11 (inaccessible area)	<input type="checkbox"/>			
Brush-blasting (non-metallic substrate)	<input type="checkbox"/>			
ABRASIVE MANUFACTURER:		ABRASIVE SIEVE SIZE:		

RECORD MEASUREMENTS TAKEN IN THE SPACES PROVIDED BELOW, TO SERVE AS PERMANENT QA RECORD. MAINTAIN SEPARATE LOG FOR EACH LOCATION. WHEN AN AREA IS DIVIDED INTO SEPARATE SECTIONS, MAINTAIN A SEPARATE LOG FOR EACH SECTION.					
Reading (mils):					
Reading (mils):					
Reading (mils):					
Reading (mils):					
Reading (mils):					
Reading (mils):					
Reading (mils):					
Reading (mils):					
Reading (mils):					
Reading (mils):					
Mean Reading (mils)					
Mean Reading (mils) IAW ASTM DD4417).					

NAME OF QP-1/NACE INSPECTOR	SIGNATURE	CERT. #	DATE / TIME

USCGC ALDER (WLB-225B) DOCKSIDE AVAILABILITY FY2020

NAME OF QP-1/NACE INSPECTOR	SIGNATURE	CERT. #	DATE / TIME

USCGC ALDER (WLB-225B) DOCKSIDE AVAILABILITY FY2020
 QA-5 - QUALITY ASSURANCE DATA FORM
 (COATING THICKNESS)

(Use one sheet for each sequence)

VESSEL NAME	HULL #	WORK ITEM #	WORK ITEM TITLE

COATING MFG	PRODUCT NAME	BATCH #	INDUCTION TIME	COATING SYSTEM SEQUENCE (PRIMER/TOUCHUP/3RD COAT, ETC.)

DRY FILM THICKNESS (DFT) MEASUREMENTS IAW SSPC-PA 2.						
SPOT	1	2	3	4	5	AVERAGE VALUE
*BASE METAL READING (BMR) Required, If Magnetic Pull-Off (Type I/Banana) Gauge Is Used.						

LOCATION (FRAME REFERENCE):								
SPOT	1	2	3	4	5	OVERALL AVG. DFT	ADJUSTMENTS	
1							AVG. BMR	DEVIATION
2								
3						BEFORE ADJUSTMENTS	AFTER ADJUSTMENTS	
AVG.								

LOCATION (FRAME REFERENCE):								
SPOT	1	2	3	4	5	OVERALL AVG. DFT	ADJUSTMENTS	
1							AVG. BMR	DEVIATION
2								
3						BEFORE ADJUSTMENTS	AFTER ADJUSTMENTS	
AVG.								

LOCATION (FRAME REFERENCE):								
SPOT	1	2	3	4	5	OVERALL AVG. DFT	ADJUSTMENTS	
1							AVG. BMR	DEVIATION
2								
3						BEFORE ADJUSTMENTS	AFTER ADJUSTMENTS	
AVG.								

APPLICATION METHOD (AIRLESS, CONVENTIONAL SPRAY, ROLLED)	AVERAGE DFT

NAME OF QP-1/NACE INSPECTOR	SIGNATURE	CERT. #	DATE / TIME

WORK ITEM 1: Chain Locker(s), Clean and Inspect

1. SCOPE

1.1 Intent. This work item describes the requirements for the Contractor to clean and inspect the Chain Locker(s).

1.2 Government-furnished property.

None.

2. REFERENCES

COAST GUARD DRAWINGS

Coast Guard Drawing 225 WLB 581-001, Rev E, Anchor Handling System Arrangement

COAST GUARD PUBLICATIONS

Surface Forces Logistics Center Standard Specification 0000 (SFLC Std Spec 0000), 2018,
General Requirements

OTHER REFERENCES

None

3. REQUIREMENTS

3.1 General. The Contractor shall refer to Coast Guard Drawing 225 WLB 581-001 for guidance in accomplishing this work item..

3.1.1 CIR.

None.

3.1.2 Tech Rep.

Not applicable.

3.1.3 Protective measures. The Contractor shall furnish and install all protective coverings to seal off and protect all non-affected vessel's components, equipment, and spaces near the work area against

USCGC ALDER (WLB-225B) DOCKSIDE AVAILABILITY FY2020

contamination during the performance of work. Upon completion of work, the Contractor shall remove all installed protective measures, inspect for the presence of contamination, and return all contaminated equipment, components, and spaces to original condition of cleanliness.

3.1.4 Interferences. The Contractor shall handle all interferences in accordance with SFLC Std Spec 0000, paragraph 3.3.5 (Interferences). Known interferences include, but are not limited to the below-listed:

- Eductor strainer.
- Anchors and chains.
- Float switch bilge alarm.
- Fluid contents of chain locker(s).
- Deck grating.

NOTE

Coast Guard personnel will operate all shipboard machinery and equipment.

3.2 Operational test - initial. Prior to commencement of work, the Contractor shall witness Coast Guard Personnel perform an initial operational test of the bilge sensor(s)/alarm(s), as applicable, to demonstrate existing operational condition. Submit a CFR.

3.3 Cleaning tasks. The Contractor shall refer to Coast Guard Drawing 225 WLB 581-001 for guidance and clean all interior surfaces free of all foreign materials, such as sediment or sludge. Remove all persistent residues, taking care not to damage the coating system. Remove cleaning media and residues continuously during the washing process. Remove any residual wash media and wipe up residual moisture with clean lint-free cloths. Collect, contain, and dispose of all wash media, residues, and cleaning materials in accordance with all Federal, state, and local regulations.

3.4 Inspection. The Contractor shall visually inspect sounding tubes and the port and starboard chain locker surfaces, including the sump, bellmouths, hawse pipes, chain pipes, bulkhead padeye and all structural members. Submit a CFR including the following, as applicable:

- Structural condition
- Inaccessible areas
- Condition of coating system, including measurements taken, percentage, location, and type of coating failure.

3.5 Operational test – post repairs. After completion of work, the Contractor shall thoroughly test, in the presence of the Coast Guard Inspector and demonstrate the bilge sensor(s)/alarm(s) to be in satisfactory operating condition. Submit a CFR.

4. NOTES

This section is not applicable to this work item.

WORK ITEM 2: Tanks (MP Fuel Service), Clean and Inspect

1. SCOPE

1.1 Intent. This work item describes the requirements for the Contractor to clean and inspect the following tank(s):

TABLE 1 - FUEL SERVICE TANKS

TYPE OF TANK	LOCATION	CAPACITY - 95% (GALLONS)	LOW SUCTION (GALLONS)
Diesel Fuel Service	3-61-1-F	4,341	137
Diesel Fuel Service	3-62-2-F	3,472	137
Incinerator Diesel Fuel Service	01-78-1-F	101	
Emergency Generator Diesel Fuel Service	02-86-2-F	576	

1.2 Government-furnished property.

None.

2. REFERENCES

COAST GUARD DRAWINGS

Coast Guard Drawing 225B WLB 541-001, Rev G; Fuel Oil System Diagram

Coast Guard Drawing 225B WLB 541-007, Rev D; Incinerator Fuel Oil Service Tank

COAST GUARD PUBLICATIONS

Surface Forces Logistics Center Standard Specification 0000 (SFLC Std Spec 0000), 2018, General Requirements

Surface Forces Logistics Center Standard Specification 0740 (SFLC Std Spec 0740), 2018, Welding and Allied Processes

OTHER REFERENCES

Society of Automotive Engineers (SAE) Aerospace Material Specification (AMS) C6183, 2013,
Cork and Rubber Composition Sheet; for Aromatic Fuel and Oil Resistant Gaskets

MIL-DTL-1222, Dec 2000, Studs, Bolts, Screws and Nuts for Applications Where a High Degree
of Reliability Is Required

3. REQUIREMENTS

3.1 General.

3.1.1 CIR. The Contractor shall submit a CIR for the inspections listed in the following paragraph(s):

- 3.9 Ultrasonic thickness (UT) measurement

3.1.2 Tech Rep.

Not applicable.

3.1.3 Protective measures. The Contractor shall furnish and install all protective coverings to seal off and protect all non-affected vessel's components, equipment, and spaces near the work area against contamination during the performance of work. Upon completion of work, the Contractor shall remove all installed protective measures, inspect for the presence of contamination, and return all contaminated equipment, components, and spaces to original condition of cleanliness.

3.1.4 Interferences. The Contractor shall handle all interferences in accordance with SFLC Std Spec 0000, paragraph 3.3.5 (Interferences). Known interferences include, but are not limited to the below-listed:

- Fuel
- Piping
- Tank access cover

3.1.4.1 The Contractor shall remove up to a total of 7,000 gallons of diesel fuel. Document a complete chain of custody record of the removed tank contents from the vessel to the point of final destination or delivery. Submit document to the COR upon completion of work.

3.1.4.2 Dispose of removed fluids in accordance with all applicable Federal, state, and local regulations (see 4.2 (Tank content restoration)).

NOTE

Vessel may come in with less tank fluid contents than specified above.

NOTE

Coast Guard personnel will operate all shipboard machinery and equipment.

USCGC ALDER (WLB-225B) DOCKSIDE AVAILABILITY FY2020

3.2 Operational test, initial. Prior to commencement of work, the Contractor shall witness Coast Guard Personnel perform an initial operational test of the TLI's for tanks listed in paragraph 1.1 (Intent), to demonstrate existing operational condition. Submit a CFR.

3.3 Plug log. The Contractor shall keep a written record of all plugs put in any tanks vents. A separate list shall be kept for each tank being entered.

3.3.1 Ensure that all plugs are removed from each tank upon completion of work in the tank.

3.3.2 Ensure the plug log is available to the Coast Guard inspector when the inspector is performing his close-out inspection on each tank.

NOTE

Initial and post repair operational tests apply only to tanks that possess TLIs.

3.4 Cleaning requirements. The Contractor shall remove tank cover(s) and clean tank interior surfaces free of all foreign materials, such as residual fuel or water, sediment, sludge, rust, or biological growth, taking care not to damage the coating system (if applicable). Remove cleaning media and residues continuously during the washing process. Remove any residual wash media; and wipe up residual moisture with clean lint-free cloths. The Contractor shall refer to Coast Guard Drawings 225B WLB 541-001 and 225B WLB 541-007 for guidance.

3.5 Tank content and waste disposal. The Contractor shall dispose of residual tank contents and any cleaning fluids in compliance with all applicable Federal, state, and local laws, ordinances and regulations. Document a complete chain of custody record of the removed tank contents and generated wastes, from the vessel to the point of final destination or delivery. Submit document to the COR upon completion of work.

3.6 Inspection. The Contractor shall accomplish the following tasks:

3.6.1 Visually inspect all tank interior surfaces, including, but not limited to bulkheads, floor and overhead plating, structural members, manhole cover surfaces, fasteners and gasket seating surfaces. Submit a CFR including the following, as applicable:

- Tank structural condition.
- Inaccessible areas.
- Condition of tank coating, including measurements taken, percentage, location, and type of coating failure (if tank interior surfaces are coated).
- Tank level indicator (TLI) and/or float switch condition, as applicable.
- Sounding/vent tube and striker plate condition.
- Suction and discharge piping condition.
- Fastener material and condition (correct fastener material is stainless steel).

3.6.2 Measure up to 10 "pits" within each tank as designated by the Coast Guard Inspector using a Contractor supplied 'Pit Gauge'. Include pit measurement results in CFR specified above, showing where pit measurements were taken and the depth of the pit.

3.7 Tank closing. The Contractor shall accomplish the following after completion of all KO-authorized repairs and/or preservation procedures:

USCGC ALDER (WLB-225B) DOCKSIDE AVAILABILITY FY2020

3.7.1 For unpainted fuel tank(s) that are not ballasted, apply a heavy coat of lube oil to the entire tank interior(s).

3.7.2 Ensure that the tank(s) remain open for at least 24 hours. Notify the COR at least 24 hours prior to closing the tank(s). After satisfactory inspection by the Coast Guard Inspector and completion of all authorized repairs, close tank manhole cover(s) with new gasket material conforming to AMS-C-6183. Chase threads on studs to ensure even installation of the access covers. Renew any damaged or missing fasteners. Use MIL-DTL-1222 as guidance. Existing undamaged fasteners may be reused. For purpose of bid, assume 10% of existing fasteners will require renewal. Renew all Nylock hex nuts.

NOTES

For cutters with unpainted fuel tanks, the 24 hour tank opening period begins after completing the lube oil coating.

Coast Guard personnel will operate all shipboard machinery and equipment.

3.8 Operational test, post repairs. After completion of work, the Contractor shall thoroughly test, in the presence of the Coast Guard Inspector and demonstrate all designated tank TLI's to be in satisfactory operating condition. Submit a CFR.

3.9 Ultrasonic thickness (UT) measurement. The Contractor shall take a total of 50 UT measurements of tank plating, in locations designated by the Coast Guard Inspector, in accordance with SFLC Std Spec 0740, Appendix C. Use Coast Guard Drawing Coast Guard Drawing 225B WLB 541-001, Rev G; Fuel Oil System Diagram as guidance. Submit a CIR.

4. NOTES

4.1 Tank content removal. The Ship's force will pump down the tanks to the maximum extent possible with the installed pumping system.

4.2 Tank content restoration. The Ship's force will procure new fluids and refill all tanks at the appropriate time.

WORK ITEM 3: Tanks (Potable Water), Clean and Inspect

1. SCOPE

1.1 Intent. This work item describes the requirements for the Contractor to clean and inspect the following tank(s):

TABLE 1 - TANKS

TYPE OF TANK	LOCATION	CAPACITY - 95% (GALLONS)	LOW SUCTION (GALLONS)
Potable Water	2-25-1-W	4,028	80
Potable Water	2-25-2-W	4,028	80

1.2 Government-furnished property.

None.

2. REFERENCES

COAST GUARD DRAWINGS

Coast Guard Drawing 225B WLB 601-001, Rev F, General Arrangement Inboard & Outboard Profiles

COAST GUARD PUBLICATIONS

Surface Forces Logistics Center Standard Specification 0000 (SFLC Std Spec 0000), 2018, General Requirements

OTHER REFERENCES

American National Standards Institute/NSF International (ANSI/NSF) 61, 2015, Drinking Water System Components - Health Effects

USCGC ALDER (WLB-225B) DOCKSIDE AVAILABILITY FY2020

American National Standards Institute/American Water Works Association (ANSI/AWWA)
C652, 2011, Disinfection of Water-Storage Facilities

3. REQUIREMENTS

3.1 General.

3.1.1 CIR.

None.

3.1.2 Tech Rep.

Not applicable.

3.1.3 Protective measures. The Contractor shall furnish and install all protective coverings to seal off and protect all non-affected vessel's components, equipment, and spaces near the work area against contamination during the performance of work. Upon completion of work, the Contractor shall remove all installed protective measures, inspect for the presence of contamination, and return all contaminated equipment, components, and spaces to original condition of cleanliness.

3.1.4 Interferences. The Contractor shall handle all interferences in accordance with SFLC Std Spec 0000, paragraph 3.3.5 (Interferences). Known interferences include, but are not limited to the following:

- Fluid contents
- Piping
- RO system components
- Deck grating.

NOTE

Coast Guard personnel will operate all shipboard machinery and equipment.

3.2 Operational test - initial. Prior to commencement of work, the Contractor shall witness Coast Guard Personnel perform an initial operational test of the TLI's for tanks listed in paragraph 1.1 (Intent), to demonstrate existing operational condition. Submit a CFR.

3.3 Plug log. The Contractor shall keep a written record of all plugs put in any tanks vents. A separate list shall be kept for each tank being entered.

3.3.1 Ensure that all plugs are removed from each tank upon completion of work in the tank.

3.3.2 Ensure the plug log is available to the Coast Guard inspector when the inspector is performing his close-out inspection on each tank.

3.4 Tank content removal. The Contractor shall remove and dispose of all fluids and/or residues in accordance with all applicable Federal, state, and local regulations. The Contractor shall notify the Dockmaster prior to filling or draining the potable water tank(s), when this item is being executed in a

USCGC ALDER (WLB-225B) DOCKSIDE AVAILABILITY FY2020

drydock availability. The Contractor shall refer to Coast Guard Drawing 225B WLB 601-001 for guidance.

3.5 Tank cleaning. The Contractor shall remove tank cover(s); clean tank interior surfaces free of all foreign materials, such as sediment, sludge and bacterial growth. Remove all persistent residues, taking care not to damage any tank coating system. Remove cleaning media and residues continuously from the tank during the washing process. Remove any residual wash media and wipe up residual moisture with clean lint-free cloths. Collect, contain, and dispose of all wash media, residues, and cleaning materials in accordance with all Federal, state, and local regulations.

3.6 Inspection. The Contractor shall visually inspect all tank interior surfaces, including, but not limited to bulkheads, floor and overhead plating, structural members, manhole cover surfaces, fasteners and gasket seating surfaces. Submit a CFR including the following, as applicable:

- Tank structural condition.
- Inaccessible areas, if any.
- Condition of tank coating, including measurements taken, percentage, location, and type of coating failure.
- Tank level indicator (TLI) and/or float switch condition (if applicable).
- Sounding tube and striker plate condition.
- Suction and discharge piping condition.
- Fastener material and condition.

3.7 Tank closing. The Contractor shall notify the COR at least 24 hours prior to closing the tank(s). After satisfactory inspection by the Coast Guard Inspector, and completion of all authorized repairs, close tank manhole cover(s) with new gasket material conforming to ANSI/NSF 61. Renew all stud cotton grommets (as applicable) upon reinstallation of manhole cover(s).

3.7.1 The Contractor shall renew 100% of nuts and washers.

3.8 Tank disinfecting. After all other work involving the potable water system and tank closing have been completed, the Contractor shall disinfect and treat the affected potable water tank(s) and associated disturbed piping and components, as necessary, to meet or exceed the requirements of AWWA C652. After tank disinfecting; remove and dispose of all treated water in accordance with all Federal, state and local regulations. Ensure that no one enters the tanks once disinfection is completed.

NOTE

Coast Guard personnel will operate all shipboard machinery and equipment.

3.9 Operational test – post repairs. After completion of work, the Contractor shall thoroughly test, in the presence of the Coast Guard Inspector and demonstrate the designated tank TLI's to be in satisfactory operating condition. Submit a CFR.

4. NOTES

USCGC ALDER (WLB-225B) DOCKSIDE AVAILABILITY FY2020

This section is not applicable to this work item.

WORK ITEM 4: Tanks (Lube Oil), Clean and Inspect

1. SCOPE

1.1 Intent. This work item describes the requirements for the Contractor to clean and inspect the following tank(s):

TABLE 1 – TANKS

TYPE OF TANK	LOCATION	CAPACITY - 95% (GALLONS)	LOW SUCTION (GALLONS)
Reduction Gear Lube Oil Storage	2-83-1-F	200	

*(Note: Tank CAPACITY - 95% at 95%)

1.2 Government-furnished property.

None.

2. REFERENCES

COAST GUARD DRAWINGS

- Coast Guard Drawing 225B WLB 601-002, Rev H, Booklet of General Drawings
- Coast Guard Drawing 225B WLB 801-005, Rev A Tank CAPACITY - 95% Curves
- Coast Guard Drawing 225 WLB 801-020, Rev B, Tank CAPACITY - 95% Curves

COAST GUARD PUBLICATIONS

- Surface Forces Logistics Center Standard Specification 0000 (SFLC Std Spec 0000), 2018, General Requirements

OTHER REFERENCES

- Society of Automotive Engineers (SAE) Aerospace Material Specification (AMS) C6183, 2013, Cork and Rubber Composition Sheet; For Aromatic Fuel and Oil Resistant Gaskets

3. REQUIREMENTS

3.1 General.

3.1.1 CIR.

None.

3.1.2 Tech Rep.

Not applicable.

3.1.3 Protective measures. The Contractor shall furnish and install all protective coverings to seal off and protect all non-affected vessel's components, equipment, and spaces near the work area against contamination during the performance of work. Upon completion of work, the Contractor shall remove all installed protective measures, inspect for the presence of contamination, and return all contaminated equipment, components, and spaces to original condition of cleanliness.

3.1.4 Interferences. The Contractor shall handle all interferences in accordance with SFLC Std Spec 0000, paragraph 3.3.5 (Interferences). Known interferences include, but are not limited to the below-listed:

- Tank cover
- Piping
- Tank contents.

3.1.4.1 The Contractor shall remove up to a total of 300 gallons of lube oil. Document a complete chain of custody record of the removed tank contents from the vessel to the point of final destination or delivery. Submit document to the COR upon completion of work.

3.1.4.2 The Contractor shall dispose of removed fluids in accordance with all applicable Federal, state, and local regulations (see 4.2 (Tank content restoration)).

NOTE

Vessel may come in with less tank fluid contents than specified above.

NOTE

Coast Guard personnel will operate all shipboard machinery and equipment.

3.2 Operational test - initial. Prior to commencement of work, the Contractor shall witness Coast Guard Personnel perform an initial operational test of the TLI's for tanks listed in paragraph 1.1 (Intent), to demonstrate existing operational condition. Use Coast Guard drawings 225B WLB 601-002, 225B WLB 801-005 and 225B WLB 801-020 for guidance. Submit a CFR.

3.3 Plug Log. The Contractor shall keep a written record of all plugs put in any tanks vents. A separate list shall be kept for each tank being entered.

3.3.1 Ensure that all plugs are removed from each tank upon completion of work in the tank.

USCGC ALDER (WLB-225B) DOCKSIDE AVAILABILITY FY2020

3.3.2 Ensure the plug log is available to the Coast Guard inspector when the inspector is performing his close-out inspection on each tank.

3.4 Cleaning requirements. The Contractor shall remove tank cover(s) and clean tank interior surfaces free of all foreign materials, such as sediment or sludge, taking care not to damage the coating system (if applicable). Remove cleaning media and residues continuously during the washing process. Remove any residual wash media; and wipe up residual moisture with clean lint-free cloths.

3.5 Tank content and waste disposal. The Contractor shall dispose of residual tank contents and all cleaning fluids in compliance with all applicable Federal, state, and local laws, ordinances and regulations. Document a complete chain of custody record of the removed tank contents and generated wastes, from the vessel to the point of final destination or delivery. Submit document to the COR upon completion of work.

3.6 Inspection. The Contractor shall visually inspect all tank interior surfaces, including, but not limited to bulkheads, floor and overhead plating, structural members, manhole cover surfaces, fasteners and gasket seating surfaces. Submit a CFR including the following, as applicable:

- Tank structural condition.
- Inaccessible areas.
- Condition of tank coating (if applicable), including measurements taken, percentage, location, and type of coating failure.
- Tank level indicator (TLI) and/or float switch condition (as applicable).
- Sounding tube and striker plate condition.
- Suction and discharge piping condition.
- Fastener material (stainless steel) and condition.

3.7 Tank closing. The Contractor shall ensure that the tank(s) remain open for at least 24 hours after completion of all KO-authorized repair and preservation procedures. Notify the COR at least 24 hours prior to closing the tank(s). After satisfactory inspection by the Coast Guard Inspector and completion of all authorized repairs, close tank manhole cover(s) with new gasket material conforming to AMS-C-6183.

NOTE

Coast Guard personnel will operate all shipboard machinery and equipment.

3.8 Operational test – post repairs. After completion of work, the Contractor shall thoroughly test, in the presence of the Coast Guard Inspector and demonstrate all designated tank TLIs to be in satisfactory operating condition. Submit a CFR.

4. NOTES

4.1 Tank content removal. The Ship's force will pump down the tanks to the maximum extent possible with the installed pumping system.

USCGC ALDER (WLB-225B) DOCKSIDE AVAILABILITY FY2020

4.2 Tank content restoration. The Ship's force will procure new fluids and refill all tanks at the appropriate time.

4.3 Tank inspection. The Coast Guard Inspector will visually inspect the tank interior immediately prior to closing.

*25901_0617_FLT
REC_25901_FLT_225' WLB 'B' Class (ALL) (0411)*

WORK ITEM 5: Main Diesel Engine (MDE) Exhaust Piping, Commercial Clean

1. SCOPE

1.1 Intent. This work item describes the requirements for the Contractor to clean the Main Diesel Engine (MDE) exhaust piping system, including the associated stack uptakes.

1.2 Government-furnished property.

None.

2. REFERENCES

COAST GUARD DRAWINGS

- Coast Guard Drawing 225B WLB 259-001, Rev C, Combustion Intake & Exhaust Diagram
- Coast Guard Drawing 225B WLB 259-005, Rev C, Combustion Intake & Exhaust A&D Hull Block 940
- Coast Guard Drawing 225B WLB 259-006, Rev C, Combustion Intake & Exhaust A&D Hull Blocks 970 & 975

COAST GUARD PUBLICATIONS

- Surface Forces Logistics Center Standard Specification 0000 (SFLC Std Spec 0000), 2018, General Requirements
- Surface Forces Logistics Center Standard Specification 6310 (SFLC Std Spec 6310), 2018, Requirements for Preservation of Ship Structures

OTHER REFERENCES

- Code of Federal Regulations (CFR) Title 29, Part 1915, 2014, Occupational Safety and Health Standards for Shipyard Employment

3. REQUIREMENTS

3.1 General.

3.1.1 CIR.

None.

3.1.2 Tech Rep.

Not applicable.

3.1.3 Protective measures. The Contractor shall furnish and install all protective coverings to seal off and protect all non-affected vessel's components, equipment, and spaces near the work area against contamination during the performance of work. Upon completion of work, the Contractor shall remove all installed protective measures, inspect for the presence of contamination, and return all contaminated equipment, components, and spaces to original condition of cleanliness.

3.1.4 Interferences. The Contractor shall handle all interferences in accordance with SFLC Std Spec 0000, paragraph 3.3.5 (Interferences). Known interferences include, but are not limited to the following:

- Exhaust insulation blankets
- Exhaust Lagging

3.1.5 Work site access. The Contractor shall gain access to both MDE exhaust stacks via existing Access 02-79-2.

3.2 Staging or scaffolding, netting. The Contractor shall erect suitable staging or scaffolding in accordance with 29 CFR 1915, Subpart E (Scaffolds, Ladders and Other Working Surfaces) to facilitate work, as required.

3.2.1 Rig suitable safety netting, to protect workers during possible falls, and to protect the Engine Room and machinery from falling tools.

3.3 Work plan. The Contractor shall develop and submit, to the COR, a plan for collecting and disposing of waste extracted during cleaning process. Ensure that the proposed plan shall detail how and where exhaust piping will be disconnected, how entire length of exhaust piping will be divided/sectioned for cleaning, and precautions to protect the MDE. The Contractor shall perform this work upon receiving Coast Guard approval of the plan.

NOTE

Coast Guard personnel will operate all shipboard machinery and equipment.

3.4 Operational test, initial. Prior to commencement of work, the Contractor shall witness Coast Guard personnel perform an initial operational test of the exhaust stack system, to demonstrate existing operational condition. Submit a CFR.

3.5 Cleaning. The Contractor shall clean the interior surfaces of the exhaust piping and stack uptakes to the MDE, shown on Coast Guard Drawings 225B WLB 259-001, 225B WLM 259-005, and 225B WLB 259-006, to a condition free from soot, tar, and any other foreign matter as follows:

USCGC ALDER (WLB-225B) DOCKSIDE AVAILABILITY FY2020

3.5.1 Disconnect the exhaust piping as necessary to facilitate cleaning.

3.5.2 Thoroughly sweep, mechanically clean, and vacuum the interior of each exhaust pipe system, including the mufflers, from the exhaust outlet to the topmost location outside the vessel. Clean all adjacent stack uptake surfaces. Ensure that all tar deposits, soot deposits, and all other surface contaminants are completely removed.

3.5.3 Remove all debris from the pipe surfaces, stack deck, and Engine Room areas by vacuuming. Dispose of all cleaning materials and generated debris in accordance with all applicable Federal, state, and local regulations.

3.5.4 Reassemble exhaust piping; renew all disturbed flange connection gaskets with suitable high temperature, non-asbestos-containing gasket materials; and renew all disturbed fasteners.

3.6 Inspection and report. The Contractor shall perform a visual inspection of the following components; submit a CFR:

- Exhaust stack access hatches, including all associated studs and nuts.
- All cleaned exhaust stack surfaces.
- All exhaust expansion joints, including associated bolts.

3.6.1 Following cleaning of the interior of each exhaust pipe system, the Contractor shall demonstrate completeness of the cleaning process to the Coast Guard Inspector, showing that the entire length of exhaust piping has been satisfactorily cleaned according to the work plan.

3.7 Touch-up preservation. The Contractor shall prepare and coat all new and disturbed surfaces to match existing adjacent surfaces in accordance with SFLC Std Spec 6310, paragraph 3.1.13 (Touch-ups and minor coating repairs.)

NOTE

Coast Guard personnel will operate all shipboard machinery and equipment.

3.8 Operational test, post repairs. After completion of work, the Contractor shall thoroughly test, in the presence of the Coast Guard Inspector and demonstrate the exhaust stack system to be in satisfactory operating condition. Submit a CFR

4. NOTES

This section is not applicable to this work item.

WORK ITEM 6: Ship Service Diesel Generator (SSDG) Exhaust Piping, Commercial Clean

1. SCOPE

1.1 Intent. This work item describes the requirements for the Contractor to clean the exhaust piping system for the following diesel generators: #1 SSDG, #2 SSDG, and the EDG, including the associated stack uptakes.

1.2 Government-furnished property.

None.

2. REFERENCES

COAST GUARD DRAWINGS

Coast Guard Drawing 225B WLB 259-001, Rev C, Combustion Intake & Exhaust Diagram

Coast Guard Drawing 225B WLB 259-005, Rev C, Combustion Intake & Exhaust A&D Hull Block 940

Coast Guard Drawing 225B WLB 259-006, Rev C, Combustion Intake & Exhaust A&D Hull Blocks 970 & 975

COAST GUARD PUBLICATIONS

Surface Forces Logistics Center Standard Specification 0000 (SFLC Std Spec 0000), 2018, General Requirements

Surface Forces Logistics Center Standard Specification 6310 (SFLC Std Spec 6310), 2018, Requirements for Preservation of Ship Structures

Surface Forces Logistics Center Standard Specification 8636 (SFLC Std Spec 8636), 2018, Temporary Hull Accesses

OTHER REFERENCES

Code of Federal Regulations (CFR) Title 29, Part 1915, 2014, Occupational Safety and Health Standards for Shipyard Employment

3. REQUIREMENTS

3.1 General.

USCGC ALDER (WLB-225B) DOCKSIDE AVAILABILITY FY2020

3.1.1 CIR.

None.

3.1.2 Tech Rep.

Not applicable.

3.1.3 Protective measures. The Contractor shall furnish and install all protective coverings to seal off and protect all non-affected vessel's components, equipment, and spaces near the work area against contamination during the performance of work. Upon completion of work, the Contractor shall remove all installed protective measures, inspect for the presence of contamination, and return all contaminated equipment, components, and spaces to original condition of cleanliness.

3.1.4 Interferences. The Contractor shall handle all interferences in accordance with SFLC Std Spec 0000, paragraph 3.3.5 (Interferences). Known interferences include, but are not limited to the following:

- Exhaust insulation blankets
- Exhaust lagging

3.2 Staging or scaffolding. The Contractor shall erect suitable staging or scaffolding in accordance with 29 CFR 1915, Subpart E (Scaffolds, Ladders and Other Working Surfaces) to facilitate work, as required.

3.3 Safety precaution. The Contractor shall rig suitable safety netting, to protect workers during possible falls, and to protect the Engine Room and machinery from falling tools.

3.3.1 Temporary safety railing. To promote safety, the Contractor shall limit existing safety railing removals to an area where new safety railing can be installed during the same workday. During periods when not actively working on new safety railing, secure any gaps between existing safety railing with a substantial temporary lifeline arrangement similar to that currently installed on the vessel. Remove and dispose of all temporary lifelines upon completion of work.

3.4 Work plan. The Contractor shall develop and submit to the COR, a plan for collecting and disposing of waste extracted during cleaning process. Ensure that the proposed plan shall detail how and where exhaust piping will be disconnected, how entire length of exhaust piping will be divided/sectioned for cleaning, and precautions to protect the SSDG. The Contractor shall perform this work upon receiving Coast Guard approval of the plan.

NOTE

Coast Guard personnel will operate all shipboard machinery and equipment.

3.5 Operational test, initial. Prior to commencement of work, the Contractor shall witness Coast Guard personnel perform an initial operational test of the exhaust piping system, to demonstrate existing operational condition. Submit a CFR.

3.6 Cleaning. The Contractor shall clean the interior surfaces of the exhaust piping and stack uptakes to the SSDG, shown on Coast Guard Drawing(s) 225B WLM 259-001, 225B WLM 259-005, and 225B WLM 259-006, to a condition free from soot, tar, and any other foreign matter as follows:

3.6.1 Disconnect the exhaust piping as necessary to facilitate cleaning.

USCGC ALDER (WLB-225B) DOCKSIDE AVAILABILITY FY2020

3.6.2 Thoroughly sweep, mechanically clean, and vacuum the interior of each exhaust pipe system, including the mufflers, from the exhaust outlet to the topmost location outside the vessel. Clean all adjacent stack uptake surfaces. Ensure that all tar deposits, soot deposits, and all other surface contaminants are completely removed.

3.6.3 Remove all debris from the pipe surfaces, stack deck, and Engine Room areas by vacuuming. Dispose of all cleaning materials and generated debris in accordance with all applicable Federal, state, and local regulations.

3.6.4 Reassemble exhaust piping; renew all disturbed flange connection gaskets with suitable high temperature, non-asbestos-containing gasket materials; and renew all disturbed fasteners.

3.7 Inspection and report. The Contractor shall perform a visual inspection of the following components; submit a CFR:

- Exhaust stack access hatches, including all associated studs and nuts.
- All cleaned exhaust stack surfaces.
- All exhaust expansion joints, including associated bolts.

3.7.1 Following cleaning of the interior of each exhaust pipe system, the Contractor shall demonstrate completeness of the cleaning process to the Coast Guard Inspector, showing that the entire length of exhaust piping has been satisfactorily cleaned according to the work plan.

3.8 Touch-up preservation. The Contractor shall prepare and coat all new and disturbed surfaces to match existing adjacent surfaces in accordance with SFLC Std Spec 6310, paragraph 3.1.13 (Touch-ups and minor coating repairs.)

NOTE

Coast Guard personnel will operate all shipboard machinery and equipment.

3.9 Operational test, post repairs. After completion of work, the Contractor shall thoroughly test, in the presence of the Coast Guard Inspector and demonstrate the exhaust piping system to be in satisfactory operating condition. Submit a CFR

4. NOTES

This section is not applicable to this work item.

WORK ITEM 7: Hydraulic Inhaul Winch, Inspect And Service**1. SCOPE**

1.1 Intent. This work item describes the requirements for the Contractor to inspect and service the hydraulic inhaul (buoy chain) winch.

1.2 Government-furnished property.

MTI	ITEM DESCRIPTION	NSN/PN	QTY	ESTIMATED COST (\$/UNIT)
N	Roller bearing Unit	NSN: 3130-01-504-4363	2 ea.	4,012.00
N	Grease seal	NSN: 5330-01-462-5544	4 ea.	79.25
N	Level wind pivot bushing	NSN: 3120-01-621-2293	1 ea.	1,139.00
N	Level wind thrust bearing	NSN: 3120-01-621-2300	2 ea.	483.30
N	Rexroth DCV	NSN: 4810-01-507-0037	1 ea.	208.29
N	Rexroth Sandwich Flow Control	NSN: 4810-01-505-9289	1 ea.	250.00
N	Sun Sandwich Relief Valves	NSN: 4820-01-439-2451	2 ea.	900.00
Y	Level Wind Hydraulic Cylinder	NSN: 3040-01-441-3721	1 ea.	7,423.00
N	3:1 Pilot Ratio, Vented Counterbalance Valve Assembly	NSN: 4820-01-563-5841	1 ea.	98.70
N	Fully Adjustable Needle Valve	NSN: 4820-01-416-0579	1 ea.	48.75
N	Wire Rope Assembly	NSN: 4010-01-646-6972	1 ea.	500.00
Y	**Hydraulic Motor	NSN: 4320-01-445-2248	1 ea.	23,998
N	**Pump, Hydraulic Ram, Hand Driven	NSN: 4320-01-286-4065	1 ea.	419.77
N	**Cylinder Pin	NSN: 5315-01-515-9847	1 ea.	500.00
N	**Cylinder Pin	NSN: 5315-01-515-9912	1 ea.	520.00

**New or refurbished equipment that the Government may provide for installation in place of existing equipment.

2. REFERENCES**COAST GUARD DRAWINGS**

Coast Guard Drawing 225B WLB 549-001, Rev A, Onboard Lubrication Requirements

Coast Guard Drawing 225B WLB 556-001, Rev F, Hydraulic System Diagram

Coast Guard Drawing 225B WLB 573-001, Rev E, Buoy Handling System Arrangement

USCGC ALDER (WLB-225B) DOCKSIDE AVAILABILITY FY2020

Coast Guard Drawing 225B WLB 573-002, Rev -, Weight Handling System Arrangement
Coast Guard Drawing FL 7101-573, Rev L, Buoy Chain Winch Assy Model CW1

COAST GUARD PUBLICATIONS

Coast Guard Technical Publication (TP) 3498, Section A, Jul 2015, Buoy Chain Winch
Surface Forces Logistics Center Standard Specification 0000 (SFLC Std Spec 0000), 2018,
General Requirements
Surface Forces Logistics Center Standard Specification 5000 (SFLC Std Spec 5000), 2018,
Auxiliary Machine Systems
Surface Forces Logistics Center Standard Specification 6310 (SFLC Std Spec 6310), 2018,
Requirements for Preservation of Ship Structures

OTHER REFERENCES

ASTM International (ASTM) D5363, 2008, Standard Specification for Anaerobic Single
Component Adhesives (AN)
MIL-S-45180, 1998; Sealing Compound, Gasket, Hydrocarbon Fluid and Water Resistant
MIL-PRF-24176 , Oct 2004, Cement, Epoxy, Metal Repair And Hull Smoothing (Metric)
The Society for Protective Coatings (SSPC)/NACE International (NACE) Joint Surface
Preparation Standard SSPC-SP 10/NACE No.2, 2007, Near-White Blast Cleaning

3. REQUIREMENTS

3.1 General.

3.1.1 CIR. The Contractor shall submit a CIR for the inspections listed in the following task(s) in Table 1:

- Task#1

3.1.2 Tech Rep.

Not applicable.

3.1.3 Protective measures. The Contractor shall furnish and install all protective coverings to seal off and protect all non-affected vessel's components, equipment, and spaces near the work area against contamination during the performance of work. Upon completion of work, the Contractor shall remove all installed protective measures, inspect for the presence of contamination, and return all contaminated equipment, components, and spaces to original condition of cleanliness.

3.1.3.1 Protective measures, hydraulic system(s). Maintain existing hydraulic system cleanliness and take all necessary precautions to prevent the introduction of contaminants into the hydraulic system. Immediately after disconnecting or removing components from the hydraulic system, seal all openings to the rest of the system using caps for externally threaded connection points, bolt-on blanks, or taped-on discs/covers made of durable plastic or sheet-metal that is no less than 1/16-inch thick.

NOTE

Be aware that plastic bags may be used only when arrangement or configuration prevents the use of the other sealing methods specified above.

USCGC ALDER (WLB-225B) DOCKSIDE AVAILABILITY FY2020

3.1.4 Interferences. The Contractor shall handle all interferences in accordance with SFLC Std Spec 0000, paragraph 3.3.5 (Interferences).

3.1.5 General hydraulic system requirements. The Contractor shall perform all work in accordance with paragraph 3.1 of SFLC Std Spec 5000, as applicable.

3.1.6 Contractor-furnished parts. The Contractor shall furnish all snap rings, bearings, thrust buttons, seals, o-rings, gaskets, seal washers, keys, shims, lockwashers, bushings, dowel pins, thrust washers, cotter pins, rope clamp, foundation bolts and nuts, as applicable, in accordance with Coast Guard Drawings 225B WLB 549-001, 225B WLB 556-001, 225B WLB 573-001, and 225B WLB 573-002.

3.2 Recurring maintenance requirements. The Contractor shall perform the tasks in Table 1 below.

TABLE 1 – RECURRING MAINTENANCE REQUIREMENTS

#	TASK TYPE (SFLC STD SPEC 5000 PARA. REF.)	QTY	COMPONENT OR ASSEMBLY	ADDITION REQUIREMENTS	
				APPENDIX AND PARA. FROM SFLC STD SPEC 5000	OTHER
1	Operate and Inspect	1	Buoy Chain In-haul Winch and Level Wind Arm Assembly	3.2.1 (Operate and Inspect)	Inspection particulars: 1. Inspect hydraulic hoses, ensuring that hose tags match hose log installation dates. 2. Visually inspect level wind arm, and hydraulic cylinder. 3. Inspect roller chock bearings, to ensure compliance with Coast Guard Drawing FL 7101- 573. 4. Inspect foundation mounting bolts. 5. Visually inspect pillow block bearings, seals, and mounting bolts; check for proper bearing alignment. 6. Inspect wire rope, hook termination, and lubrication. 7. Inspect pinion and drum drive gears. Check for proper lubrication. 8. Check gear train backlash, to ensure whether backlash is between .020 and .030 inch. 10. Check hydraulic motor for proper alignment, Check all hardware and pinion seals for leakage

USCGC ALDER (WLB-225B) DOCKSIDE AVAILABILITY FY2020

				ADDITION REQUIREMENTS	
#	TASK TYPE (SFLC STD SPEC 5000 PARA. REF.)	QTY	COMPONENT OR ASSEMBLY	APPENDIX AND PARA. FROM SFLC STD SPEC 5000	OTHER
					11. Inspect hydraulic controls for corrosion and freedom of operation/adjustment (including emergency brake components). 12. Check chain winch speed; document whether satisfactory or not. 13. Check level wind speed; document whether satisfactory or not. 14. Verify level wind arm relief valve settings. 15. Inspect chain winch remote's handle and rubber boot. 16. Check and operate chain winch and level wind arm controls from remove (crane booth or shack). 17. Inspect the winch ratchet pawl for proper operation of the pawl and lock pin. Submit a CIR.
2	Service and Inspect	1	Ratchet Pawl Assembly	3.2.2 (Service and inspect)	Submit a CFR.
3	Service and Inspect	1	Bull and Pinion Gears	D2.4 (Open Gearing And Gear Reducers)	Submit a CFR.
4	Inspect and Preserve	1	Winch Drum and Shaft Assembly (External Surfaces)	3.2.4 (Preserve)	1. Visual inspection of inspection of the load bearing ends of the shaft for cracks. Submit a CFR. 2. Abrasive-blast drum shaft to "Near-White", in accordance with SSPC-SP 10. 3. Coat blasted surfaces with one coat 3.0-4.0 mils DFT Inorganic Zinc (See SFLC Std Spec 6310, Appendix C).
5	Preserve		Winch Drum (Internal Surfaces)	N/A	1. Fill interior winch drum with 10 gallons of rust preventive compound conforming to MIL-PRF-

USCGC ALDER (WLB-225B) DOCKSIDE AVAILABILITY FY2020

				ADDITION REQUIREMENTS	
#	TASK TYPE (SFLC STD SPEC 5000 PARA. REF.)	QTY	COMPONENT OR ASSEMBLY	APPENDIX AND PARA. FROM SFLC STD SPEC 5000	OTHER
					16173, Class II, Grade 3, and rotate drum for 5 minutes to coat all interior surfaces and then drain. 2. Drain, collect, and dispose of drained compound in accordance with all applicable Federal, state, and local regulations. Ensure that the coated surfaces are left exposed to the atmosphere for 24 hours to allow for adequate drying. 3. Renew each plug with a new stainless steel, Type 316, or Monel drain plug. Coat new plugs prior to installation with a sealing and locking compound conforming to ASTM D5363-AN0123 or a flexible joint compound conforming to MIL-S-45180, Type II.
6	Service and Inspect	1	Roller Chock Shaft Assembly	3.2.2 (Service and inspect)	GFP. Submit a CFR.
7	Service and Inspect	1	Level Wind Arm Pivot Pin Assembly	3.2.2 (Service and inspect)	GFP. Submit a CFR.
8	Renew and Preserve	1	Level Wind Arm Hydraulic Cylinder	3.2.4 (Preserve)	GFP.
9	Renew		Wire rope assembly	D2.2 (Wire Rope Assemblies)	GFP.
10	Renew	1	Level Wind Cylinder Control Block	C2.4 (Valves And Manifolds)	GFP
11	Service and Inspect	1	Chain Winch Control Block	C2.4 (Valves And Manifolds)	GFP Submit a CFR.
12	Renew	1	Level Wind Hydraulic Cylinder.		GFP
13	Renew	18	Buoy Chain In-haul Winch Foundation Bolts	D2.1(Fastener Assemblies)	Type: 1"-8UNC-2A x 4-1/2" LG, SS 316 Torque value: See Table 6-1 in TP-3498.
14	NDE	1	Buoy Chain In-haul Winch and Level Wind Arm Assembly Foundations	3.2.5 (NDE)	Weld joints to NDE: all joints attaching winch foundations to deck. Submit a CFR.
15	Preserve	1	Buoy Chain In-haul	3.2.4 (Preservation)	Surfaces to be preserved

USCGC ALDER (WLB-225B) DOCKSIDE AVAILABILITY FY2020

				ADDITION REQUIREMENTS	
#	TASK TYPE (SFLC STD SPEC 5000 PARA. REF.)	QTY	COMPONENT OR ASSEMBLY	APPENDIX AND PARA. FROM SFLC STD SPEC 5000	OTHER
			Winch Assembly and Level Wind Arm Assembly		include, but are not limited to: winch drum shaft assembly, ratchet pawl assembly, level wind arm hydraulic cylinder, and all previously coated surfaces.
16	Renew	1	Counterbalance Valve Assembly, and Fully Adjustable Needle Valve	C2.4 (Valves And Manifolds)	GFP, Adjust Counterbalance manifold setting Appendix F of Tech Pub 3498.
17	Renew	1	Hydraulic motor		GFP
18	Align	1	Buoy Chain In-haul Winch Assembly		Perform alignment per Appendix E of Tech Pub 3498, Chain Winch Realignment Instructions. Submit a CFR
19	Renew	1	Hand Pump		GFP
20	Groom and Lubricate	1	Buoy Chain In-haul Winch and Level Wind Arm Assembly	3.2.6 (Groom and Lubricate)	Perform all adjustments in Chapter 6-2 of TP-3498.
21	Weight Test	1	Buoy Chain In-haul Winch and Level Wind Arm Assembly	N/A	Perform all weight testing In accordance TP-3498, Chapter 6, paragraph 8-6.4, Inspection and test procedures for the Buoy Chain Winch Model CW-1 onboard 175WLM, 225 WLB, and 240 WLBB class cutters. See Table 2 below. Submit a CFR.
22	Fabricate and Install	1	Label plate	B2.9 (Label Plates)	

NOTE
Coast Guard personnel will operate all machinery during testing.

TABLE 2 – TEST WEIGHTS

	MAIN HOIST TEST WEIGHTS
Static	24,750 (+5% - 0%) lbs
Rated	16,500 (+5% - 0%) lbs
Emergency Brake Release	5,000 (+0% - 5%) lbs

3.3 Additional maintenance requirements. The Contractor shall perform tasks in Table 3 below marked with an “X”. Submit a CFR to document all inspections and recommended additional repairs. Combine or group CFR, as required, to minimize administrative burden and maximize efficiency.

USCGC ALDER (WLB-225B) DOCKSIDE AVAILABILITY FY2020

NOTE

Tasks not initially marked with an “X” must be exercised via authorized and released Change Requests (CR), when determined to be necessary by inspection results.

TABLE 3 – ADDITIONAL MAINTENANCE REQUIREMENTS

				ADDITIONAL REQUIREMENTS	
X	TASK TYPE (SFLC STD SPEC 5000 PARA. REF.)	QTY	COMPONENT OR ASSEMBLY	APPENDIX AND PARA. FROM SFLC STD SPEC 5000	OTHER
X	Preserve	1	Winch Drum (Internal Surfaces)	N/A	1. Drill and tap two one- inch drain and fill holes, in locations designated by the CG Inspector. 2. Preserve internal surfaces, as specified in Task # 5 of Table I. 3. Plug each hole with a new stainless steel, Type 316, or Monel plug. 4. Coat new plugs prior to installation with a sealing and locking compound conforming to ASTM D5363-AN0123 or a flexible joint compound conforming to MIL-S-45180, Type II.
	Renew	All	All Externally Installed Hose Assemblies	C2.2 (Hose Assemblies)	
	Disassemble and Inspect	1	Ratchet Pawl Assembly	3.2.3 (Disassemble and Inspect)	Submit a CIR.
	Disassemble and Inspect	1	Bull and Pinion Gears	D2.4 (Open Gearing And Gear Reducers)	Submit a CIR.
	Disassemble and Inspect	1	Roller Chock Shaft Assembly	3.2.3 (Disassemble and Inspect)	Submit a CIR. GFP.
	Disassemble and Inspect	1	Level Wind Arm Pivot Pin Assembly	3.2.3 (Disassemble and Inspect)	Submit a CIR. GFP.
	Disassemble and Inspect	1	Level Wind Cylinder Control Block	C2.4 (Valves And Manifolds)	Submit a CIR.

USCGC ALDER (WLB-225B) DOCKSIDE AVAILABILITY FY2020

	Disassemble and Inspect	1	Chain Winch Control Block	C2.4 (Valves And Manifolds)	Submit a CIR.
	Disassemble and Inspect	1	Brake Control Block	C2.4 (Valves And Manifolds)	Submit a CIR.
	Disassemble and Inspect	1	Hydraulic motor	3.2.3 (Disassemble and Inspect)	Perform alignment per Appendix E of Tech Pub 3498, Chain Winch Realignment Instructions. Submit a CIR.
	Renew	1	Hand Pump and Isolation Valves	C2.4 (Valves And Manifolds)	GFP.
	Renew	1	Hydraulic motor	3.2.4 (Preservation)	GFP. Return the original hydraulic motor to the CG PA as a MTI. Perform alignment per Appendix E of Tech Pub 3498, Chain Winch Realignment Instructions.
	Renew and Preserve	1	Level Wind Arm Hydraulic Cylinder	3.2.4 (Preservation)	GFP.
	Disassemble and inspect	1	Winch Drum Shaft Assembly	3.2.3 (Disassemble and inspect)	Submit a CIR. GFP.
	Disassemble and Inspect	1	Roller Chock Shaft Assembly	3.2.3 (Disassemble and inspect)	Submit a CIR. GFP.
	Disassemble and Inspect	1	Level Wind Arm Pivot Pin Assembly	3.2.3 (Disassemble and inspect)	Submit a CIR. GFP.
	Renew	1	Hand Pump and Isolation Valves	C2.4 (Valves And Manifolds)	GFP.
	Renew	1	Level Wind Arm Hydraulic Cylinder	3.2.4 (Preserve)	GFP.
	Renew	1	Wire rope assembly	D2.2 (Wire Rope Assemblies)	Nominal diameter: 1-1/8 inch Nominal strength: XIPS Total length of rope required: 150 ft. End fitting type: Fiege OR poured spelter.

USCGC ALDER (WLB-225B) DOCKSIDE AVAILABILITY FY2020

	Renew	18	Buoy Chain In-haul Winch Foundation Bolts	D2.1(Fastener Assemblies)	Type: 1"-8UNC-2A x 4-1/2" LG, SS 316 Torque value: See Table 6-1 in TP-3498.
	Renew	1	Counterbalance Valve Assembly, and Fully Adjustable Needle Valve	C2.4 (Valves And Manifolds)	GFP, Adjust Counterbalance manifold setting Appendix F of Tech Pub 3498.

4. NOTES

This section is not applicable to this work item.

WORK ITEM 8: Anchor Windlass, Inspect and Service

1. SCOPE

1.1 Intent. This work item describes the requirements for the Contractor to inspect and service the port and starboard Appleton Model BMD-478 Anchor Windlasses.

1.2 Government-furnished property.

None.

2. REFERENCES

COAST GUARD DRAWINGS

Coast Guard Drawing 225B WLB 581-001, Rev C, Anchor Handling System Arrangement

COAST GUARD PUBLICATIONS

Coast Guard Technical Publication (TP) 3559, SWBS 581B, Anchor Windlass, P/S - Model BMD-478

Surface Forces Logistics Center Standard Specification 5000 (SFLC Std Spec 5000), 2018, Auxiliary Machine Systems

OTHER REFERENCES

None

3. REQUIREMENTS

3.1 General.

3.1.1 CIR. The Contractor shall submit a CIR for the inspections listed in Table 1:

- Task # 1.
- Task # 2.
- Task # 3.
- Task # 7.
- Task # 9.

3.1.2 Tech Rep.

USCGC ALDER (WLB-225B) DOCKSIDE AVAILABILITY FY2020

Not applicable.

3.1.3 Protective measures. The Contractor shall furnish and install all protective coverings to seal off and protect all non-affected vessel's components, equipment, and spaces near the work area against contamination during the performance of work. Upon completion of work, the Contractor shall remove all installed protective measures, inspect for the presence of contamination, and return all contaminated equipment, components, and spaces to original condition of cleanliness.

3.1.4 Interferences. The Contractor shall handle all interferences in accordance with SFLC Std Spec 0000, paragraph 3.3.5 (Interferences). Known interferences include, but are not limited to the below-listed:

- Port and starboard anchors (remove at the swivel shot).
- Port and starboard anchor chains.

NOTE
Each anchor weighs 4,000 pounds and each chain is 1-1/4 inch Stud-Link, Grade III with a length of 8 shots.

3.2 Inspection and repair. The Contractor shall accomplish the tasks specified in Table 1, in accordance with SFLC Std Spec 5000, TP 3559 SWBS 581B, and Coast Guard Drawing 225B WLB 581-001.

TABLE 1 – RECURRING MAINTENANCE REQUIREMENTS

#	TASK TYPE	QTY	COMPONENT OR ASSEMBLY	ADDITIONAL REQUIREMENTS	
				APPENDIX AND PARA. FROM SFLC STD SPEC 5000	OTHER
1	Operate and Inspect	2	Anchor Windlass Assembly	3.2.1 (Operate and inspect)	Submit A CIR.
2	Disassemble and Inspect	2	Hydraulic Disc Brake Assembly	D2.3 (Brakes and clutches)	Submit A CIR.
3	Disassemble and Inspect	2	Planetary Gear Box Assembly	D2.4 (Open gearing and gear reducers)	Submit A CIR.
4	Renew	2	Main Planetary Gear Box Oil	D2.4 (Open gearing and gear reducers)	See CG TP 3559 SWBS 581B.
5	Service and Inspect	2	Band Brake Assembly	D2.3 (Brakes and clutches)	Submit a CFR.
6	Service and Inspect	2	Band Brake Handwheel, Bevel Gear Box, and Linkage Assemblies up the Band Brake Assembly	D2.3 (Brakes and clutches)	Submit a CFR.
7	Disassemble and Inspect	2	Directional Control Valve assembly	C2.4 (Valves and manifolds)	Submit A CIR.
8	Service and Inspect	2	Hand Pump assembly	3.2.2 (Service and inspect)	Submit a CFR.
9	Disassemble and Inspect	2	Holding Valve assembly	C2.4 (Valves and manifolds)	Submit A CIR.
10	NDE	2	Anchor windlass assembly and	3.2.5 (NDE)	Weld joints to NDE: all joints attaching winch

USCGC ALDER (WLB-225B) DOCKSIDE AVAILABILITY FY2020

				ADDITIONAL REQUIREMENTS	
#	TASK TYPE	QTY	COMPONENT OR ASSEMBLY	APPENDIX AND PARA. FROM SFLC STD SPEC 5000	OTHER
			foundation		foundations to deck. Submit a CFR.
11	Preserve	2	Anchor Windlass Assembly Components	3.2.4 (Preservation)	Preserve all previously coated components. Anchor windlasses are considered “critical-coated surfaces”, as defined in SFLC Std Spec 0000.
12	Renew	All	Snap Rings, Bearings, Thrust Buttons, Seals, O-Rings, Gaskets, Seal Washers, Keys, Shims, Lockwashers, Bushings, Dowel Pins, Thrust Washers, Cotter Pins, Rope Clamp, Foundation Bolts And Nuts .		Perform all renewals during reassembly and reinstallation, in accordance with CG TP 3559 SWBS 581B.
13	Groom and Lubricate	2	Anchor windlass assembly	3.2.6 (Groom and lubricate)	
14	Final Operational and/or weight test	2	Anchor Windlass	B2.5 (Anchor windlass)	Submit CFR.
15	Fabricate and Install	2	Label plate	B2.9 (label plates)	System: Anchor Windlass

4. NOTES

This section is not applicable to this work item.

WORK ITEM 9: Twin Pivot Arm Davit, Inspect and Service

1. SCOPE

1.1 Intent. This work item describes the requirements for the Contractor to perform inspections and service for the Welin-Lamibe Twin Pivot Arm Davit model TW.PIV 5.0A.

1.2 Government-furnished property.

MTI	ITEM DESCRIPTION	NSN/PN	QTY	ESTIMATED COST (\$/UNIT)
N	Wire Rope Renewal Kit	NSN: 3950-01-F13-3314 PN: 892-02060	1 ea.	5,302.00
N	Check Winch Gearbox Oil Kit	NSN: 5330-01-F13-3315 PN: 892-02061	1 ea.	64.00
N	Hydraulic Fluid Filter Renewal Kit	NSN: 3950-01-F13-3316 PN: 892-02063	1 ea.	2,108.00
N	Main Winch Brake and Centrifugal Brake Inspection Kit	NSN: 3950-01-F13-3299 PN: 892-02064	1 ea.	908.00
N	Hydraulic Breather Replacement Kit	NSN: 4310-01-F13-3300 PN: 892-02065	1 ea.	228.00
N	Hydraulic Hose Replacement Kit	NSN: 4720-99-553-9143 PN: 892-02066	1 ea.	1,600.00

2. REFERENCES

COAST GUARD DRAWINGS

None

COAST GUARD PUBLICATIONS

Coast Guard Technical Publication (TP) 3762, 15-OCT-04, Dual Point Davit - ATON Workboat - Model TWPIV5-0A 5

Surface Forces Logistics Center Standard Specification 5000 (SFLC Std Spec 5000), 2018, Auxiliary Machine Systems

Surface Forces Logistics Center Standard Specification 3020 (SFLC Std Spec 3020), 2018, Overhaul AC Electrical Motors

OTHER REFERENCES

None

3. REQUIREMENTS

3.1 General.

3.1.1 CIR. The Contractor shall submit a CIR for the following inspections listed in Table 1:

- Task #1.

3.1.2 Tech Rep. The Contractor shall provide the services of an OEM authorized/ licensed Tech Rep for the Welin Lambie TWPIV 5.0A Dual Point Davit to accomplish the following on site:

- Provide manufacturer's proprietary system/ equipment information, software, and tools.
- Assist with and ensure compliance with manufacturer's procedures and standards during disassembly, inspection, repair, modification, calibration, and reassembly of the equipment/system.

3.1.2.1 Ensure the Tech Rep is an OEM Certified Representative for the system/equipment stated above and demonstrated on their résumé.

3.1.3 Protective measures, general. The Contractor shall furnish and install all protective coverings to seal off and protect all non-affected vessel's components, equipment, and spaces near the work area against contamination during the performance of work. Upon completion of work, the Contractor shall remove all installed protective measures, inspect for the presence of contamination, and return all contaminated equipment, components, and spaces to original condition of cleanliness.

3.1.3.1 Protective measures, hydraulic system(s). Maintain existing hydraulic system cleanliness and take all necessary precautions to prevent the introduction of contaminants into the hydraulic system. Immediately after disconnecting or removing components from the hydraulic system, seal all openings to the rest of the system using caps for externally threaded connection points, bolt-on blanks, or taped-on discs/covers made of durable plastic or sheet-metal that is no less than 1/16-inch thick.

NOTE

Be aware that plastic bags may be used only when arrangement or configuration prevents the use of the other sealing methods specified above.

3.1.4 Interferences. The Contractor shall handle all interferences in accordance with SFLC Std Spec 0000, paragraph 3.3.5 (Interferences). Known interferences include, but are not limited to the below-listed:

- Small Boat.

3.2 Tasks to be accomplished. The Contractor shall perform the tasks designated in Table 1 below. The Contractor shall use TP 3762 for guidance. Perform all work in accordance with SFLC Std Spec 5000.

USCGC ALDER (WLB-225B) DOCKSIDE AVAILABILITY FY2020

TABLE 1 – RECURRING TASKS

#	TASK TYPE (SFLC STD SPEC 5000 PARA. REF.)	QTY	COMPONENT OR ASSEMBLY	APPENDIX AND PARA. FROM SFLC STD SPEC 5000	OTHER
1	Operate and Inspect	1	Twin Pivot Arm Davit	3.2.1 (Operate and Inspect)	Submit a CIR.
2	Fluid Sampling	1	Twin Pivot Arm Davit	C2.1 (Fluids)	Submit a CFR.
3	Service and Inspect	All	Twin Pivot Arm Davit Structure and Rigging	3.2.2 (Service and inspect)	Renew GFP wire rope. Submit a CFR.
4	Service and Inspect	2	Electric Motors		Clean each motor and Perform insulation resistance of winding per SFLC Std Spec 3020, paragraph 3.3.3.1. Submit a CFR.
5	Service and Inspect	1	Main Winch	3.2.2 (Service and inspect)	Renew GFP gearbox oil kit, main and centrifugal brake kit. Provide and flush gearbox and renew gearbox oil. Submit a CFR
6	Service and Inspect	1	HPU	3.2.2 (Service and inspect) C2.4 (Valves and manifolds)	Submit a CFR. Install GPF breather and hose kits.
7	Service and Inspect	2	Accumulators	3.2.2 (Service and inspect)	Submit a CFR
8	Service and inspect	All	Sensors and controls	3.2.2 (Service and inspect)	Submit a CFR.
9	Preserve	1	Twin Pivot Arm Davit and foundation	3.2.4 (Preservation)	
10	Groom and Lubricate	1	Twin Pivot Arm Davit	3.2.6 (Groom and Lubricate)	
11	Operational and Weight Test		Twin Pivot Arm Davit	3.2.8 (Operational and weight test) B2.4 (Boom and crane) B2.7.2 (Dual point davits)	The Contractor shall perform tests either by using a single water bag at the below weights with an appropriately sized crossbar or by using two water bags simultaneously at 50% of the below weights each (Rated: 4,950 lbs, Dynamic: 6,188 lbs, and Static: 7,425 lbs). The angle between the crossbar and wire ropes shall be 90 degrees. The Contractor shall submit a test plan to the COR for approval at least 24 hours prior to testing. Rated load test: 9,900 (+0 –

USCGC ALDER (WLB-225B) DOCKSIDE AVAILABILITY FY2020

#	TASK TYPE (SFLC STD SPEC 5000 PARA. REF.)	QTY	COMPONENT OR ASSEMBLY	APPENDIX AND PARA. FROM SFLC STD SPEC 5000	OTHER
					495) lbs at hoist speed 72 ft/min. Dynamic load test: 12,375 (+620 – 0) lbs. Static load test: 14,850 (+742 – 0) lbs. Submit a CFR.
12	Fabricate and Install}	1	Label Plate	B2.9 (Label Plates)	
13	Weatherize	All	Hose fittings	C2.2.1.2.2 (Weatherization).	

3.3 Additional maintenance requirements. The Contractor shall perform the tasks below marked with an “X”. Submit CFR(s) to document all inspections, to recommend additional repairs, and to document completed maintenance and repair tasks. Combine or group CFRs, as required, to minimize administrative burden and maximize efficiency.

TABLE 2 – ADDITIONAL TASKS

ADDITIONAL TASK	TASK TYPE	QTY	COMPONENT OR ASSEMBLY	APPENDIX AND PARA. FROM SFLC STD SPEC 5000	OTHER
—	Renew	All	Hose Assemblies	C2.2 (Hose assemblies)	
—	{example}: Service and Inspect	1	Outer Boom Hydraulic Cylinder Assembly	3.2.2 (Service and Inspect)	Submit CFR
—	{example}: Renew	3	Slew Drive Brake Assembly	D2.3 (Brakes and clutches)	Submit CFR
—	{example}: Renew	1	Hoist Hook		GFP
—	{example}: Disassemble and Inspect	1	Hydraulic Manifold Assembly and Associated Valves for Luff, Swing, and CT	3.2.3 (Disassemble and Inspect)	Submit a CIR.
—	{example}: Service and Inspect	1	Hydraulic Valve Assembly for Main and Aux Winches	C2.4 (Valves And Manifolds)	Submit CFR.

4. NOTES

This section is not applicable to this work item.

WORK ITEM 10: SSDG Isolation Mount, Renew

1. SCOPE

1.1 Intent. This work item describes the requirements for the Contractor to renew the isolation mounts on both ship's service diesel generator skids. There are currently six or seven mounts on each service diesel generator, in all cases only six mounts will be continued. During this renewal new steel soleplate configuration will be adopted.

1.2 Government-furnished property.

MTI	ITEM DESCRIPTION	NSN/PN	QTY	ESTIMATED COST (\$/UNIT)
N	Christie & Grey Isolation Mount T2.S20.45.C0.100 TSC T2 20/45 (UTS threads)	NSN: 5340-99-613-8406	8 ea.	558
N	Christie & Grey Isolation Mount T2.S20.55.C0.100 TSC T2 20/55 (UTS threads)	NSN: 5340-99-501-0478	4 ea.	558
N	Christie & Grey Sole Plate54378 rev A	NSN: 5340-99-387-2519	12 ea.	98

2. REFERENCES

COAST GUARD DRAWINGS

Coast Guard Drawing 225B-WLB 180-10, Rev -, Generator Foundations

Coast Guard Drawing 225B-WLB 256-7, Rev -, Heat Exchanger Modifications for CAT 3508 SSDG

COAST GUARD PUBLICATIONS

Surface Forces Logistics Center Standard Specification 0000 (SFLC Std Spec 0000), 2018, General Requirements

Surface Forces Logistics Center Standard Specification 0740 (SFLC Std Spec 0740), 2018, Welding and Allied Processes

Surface Forces Logistics Center Standard Specification 6310 (SFLC Std Spec 6310), 2018, Requirements for Preservation of Ship Structures

Coast Guard Technical Publication (TP) 3537A, 07-MAY-01, Ship's Service Diesel Generator Set (SSDG) - Model 3508

USCGC ALDER (WLB-225B) DOCKSIDE AVAILABILITY FY2020

Coast Guard Technical Publication (TP) 3537B, 07-MAY-01, Ship's Service Diesel Generator Set (SSDG) - Model 3508

OTHER REFERENCES

The Society for Protective Coatings (SSPC) Surface Preparation Specification No.1 (SSPC-SP 1), 2004, Solvent Cleaning

Christie & Grey Data Sheet DS 094 - Instructions for the measurement of mounting heights using either spring loaded telescopic gauges or a digital DTI set

Christie & Grey Data Sheet DS 096 - Mount Height Data Collection Sheet For New Installations and In Service Maintenance Checks - Marine Diesel Engines

Christie & Grey Drawing No. 44560 Isolation of Caterpillar 3508 Generator Set

Chockfast® Orange, or equivalent, general Guidelines for Marine Chock Designers Bulletin No. 692D

3. REQUIREMENTS

3.1 General.

3.1.1 CIR.

None.

3.1.2 Tech Rep.

None

3.1.3 Protective measures. The Contractor shall furnish and install suitable covering to seal off and protect all non-affected surfaces/equipment and spaces in the vicinity of the work area against contamination during the performance of work. Upon completion of work, remove protective material and inspect for the presence of contamination. Clean all equipment and spaces, contaminated due to improper protection, to original condition of cleanliness.

3.1.4 Interferences. The Contractor shall handle all interferences in accordance with SFLC Std Spec 0000, paragraph 3.3.5 (Interferences).

NOTE

Each ship's service diesel generator is held in place by six (6) Christie & Grey Model T2.S20.45.C0.100-TSC-T2-20/45 engine mounts. Some ship's service diesel generators may have been fitted with a seventh experimental mount (in that case it will not be replaced, since new install only uses six). The engine mounts are placed in a Chockfast® Orange, or equivalent surface and the engine is bolted to the engine mounts. Photographs of typical SSDG engine mounts (from another ship of this class) are attached to the end of this specification item.

3.1.5 The intent of this item is to change the arrangement of the vibration mounts on the base of the skids of both Ship's Service Diesel Generator (SSDG) assemblies. The existing Chockfast® Orange, or

equivalent under each vibration mount will be removed and new soleplates with accompanying Chockfast® Orange, or equivalent installed. New vibration mounts will be installed. The work is to be performed in accordance with the instructions given in Christie & Grey Drawing No. 44560 and Christie & Grey Technical Data Sheet DS-096.

CAUTION!

The internal surfaces of diesel engines, pipe, hoses, and components are particularly susceptible to corrosion and contamination damage. The Contractor shall protect and exclude water moisture & air borne contaminants with effective covering and sealing (plastic cap, metal cap, blank flange with a gasket) of all openings. Cap (plastic cap, metal cap, blank flange with a gasket) all open lines immediately after breaking.

3.1.6 The Contractor is strongly encouraged to perform a ship check, prior to submitting a bid, in order to identify the interferences, available space, adequacy of overhead supporting beams/clamps, bracing the engine assemblies, and actual configuration. The mounts are available onboard for inspection.

3.1.5 The concerned work area is the Main Machinery Room (4-66-0-E).

3.1.6 Follow all safety precautions of the manufacturer. Personnel safety is always the number one consideration when working around/under machines.

3.2 Safety. The Contractor shall be responsible for suspending, bracing, and supporting the SSDG assemblies during this work. Ensure the safety of the Cutter and personnel. Obtain verification from the CG Inspector that SSDG assemblies are supported.

3.3 Op test. Prior to commencing work, the Contractor shall operationally test the SSDG. Demonstrate proper operation and acceptance of ships service electrical load. Submit CFR.

3.4 Tag Outs. The Contractor shall tag out all heaters, control electronics, start air, and cooling systems attached to the SSDG's for the duration of the contract.

3.5 Initial skid height measurements and exhaust adjustments. To ensure that accurate measurements are made for this installation, the Contractor shall devise a repeatable measurement system to accurately measure the before and after heights at four points (corners) of the SSDG to fixed structure of the ship near each SSDGs.

3.5.1 The existing Christie & Grey mounts are installed without the use of soleplates and are set into the Chockfast® Orange, or equivalent on the foundations. Accurate measurements of engine skid height off the ship's structural foundations are difficult. When the mounts are renewed using soleplates the generators will sit higher, requiring an adjustment to the exhaust system height and other service connections (e.g. raw water supply and discharge, jacket water, and lube oil). It is important to know the difference in height from existing to new mount installation so appropriate considerations may be made regarding service connections.

3.5.2 Provide A CFR identifying the locations and measurements before and after the mount renewal. Perform these measurements in the presence of the COR.

3.6 Disconnect service connections and drain fluids. The Contractor shall disconnect the engine exhaust from the expansion bellows. Measure and record the height difference between the engines exhaust outlet

USCGC ALDER (WLB-225B) DOCKSIDE AVAILABILITY FY2020

and the exhaust duct inlet to verify previous alignment of the exhaust bellows when free. This measurement is important for future reference.

3.6.1 Drain and disconnect the two SSDG assemblies fluid systems including fuel oil supply and return, sea water, and lube oil systems as required to jack up the engine skids to replace the vibration mount assemblies. Approximately 75 gallons jacket water, 66 gallons lube oil, and 5 gallons fuel oil per engine assembly are involved. The engine jacket water contains Caterpillar ELC coolant. Remove the SSDG fluids from the Cutter and dispose of in accordance with all applicable federal, state, and local regulations.

NOTE

It is assumed that the above fluids will be required to be drained. Contractor may submit a proposal requesting to the Coast Guard Inspector that specific fluids not drained. Coast Guard reserves the sole right to approve or disapprove of any such requests. The ELC jacket water may be drained into clean containers, covered, and reused after it is filtered for debris prior to reentering engines.

3.6.2 Seal each end of each fuel line, lube oil line, water line, and starting air line, each SSDG connection immediately upon disconnection, with clean plastic caps, plugs, or flange with gasket to prevent contamination in accordance with NAVSEA Std Item 009-24. Rags and wooden plugs shall not be used. Obtain verification from the CG Inspector for protective measures.

3.6.3 Disassemble the generator as required (removable panels or covers) to take air gap readings on the generator. Take and record air gap readings in four locations each at the aft end of each generator.

3.6.4 The following Table describes the SSDG flexible connections of concern when lifting the SSDG.

TABLE 1. FLEXIBLE CONNECTIONS

FLUID APPLICATION	LOCATION	DETAILS
Exhaust Piping	Aft end, starboard side and overhead.	Exhaust flange bellows will not accommodate the 3" upward movement of engine. Remove and replace after mounts are redone and exhaust is realigned. Exhaust will require modification to align bellows upon reinstallation
Combustion Air Inlet Ducts	Aft	Disconnect for lift. Reconnect after generator is on mounts again; modify if necessary.
Gauge Lines	Gauge Board - fwd port corner of engine.	Inspect for adequate slack. Monitor during jacking to ensure none become tight. Identify and tag, drain, disconnect, and plug any lines that do not have adequate slack.

USCGC ALDER (WLB-225B) DOCKSIDE AVAILABILITY FY2020

SW Cooling Supply & Discharge	Front end, above deck plates.	Disconnect sea water supply piping to Raw Water Pump, remembering to shut down the appropriate sea chest valve and to tag out the system. Disconnect Raw Water discharge. Blank flange pipe opening to prevent any S/W leakage past shut valves. It is expected S/W piping/hoses will reconnect after SSDG is on new mounts, submit CFR to document any recommended changes (if hoses do not fit on new mounts).
Jacket Water Heat Exchanger	Beneath JW Heat Exchanger, starboard side.	For first installation with sole plate, do all system modifications to remove heat exchanger from generator set foundation and place it on the deck. The details of this modification are in a separate specification. This will require removing all piping running from the engine to the coolers (4 ea) and removal of cooler mounting brackets from the skid (1 ea) prior to jacking the engine up All welding on the deck for new foundation shall occur prior to pouring of chockfast dams as welding may cause deck to deflect.
Jacket Water Expansion Tank	Fwd end, in overhead.	Disconnect hose. Modification of hose or shortening of hard piping off of head tank may be required to ensure sufficient hose bend radius.
Aftercooler heat exchanger	Port side of engine, aft	For first installation with sole plate, do all system modifications to remove heat exchanger from generator set foundation and place it on the deck. The details of this modification are in a separate specification. This will require removing all piping running from the engine to the coolers (4 ea) and removal of cooler mounting brackets from the skid (1 ea) prior to jacking the engine up.
Lube Oil Supply	Fwd end, port side	Disconnect all lines as there is not enough slack for 3" movement
Lube Oil Drain	Centerline, aft end of engine.	Leave hose connected.

USCGC ALDER (WLB-225B) DOCKSIDE AVAILABILITY FY2020

Fuel Oil (2 lines)	Aft starboard corner, beneath deck plates.	All hoses sufficiently long to accommodate upward motion.
Generator Power Cables	Starboard side of generator set alongside generator	Remove cable ties above and below deck. Monitor cables during jacking operation to ensure that slack exists, particularly at lugs. Remove if lugs are strained. After generator is in final position, restore all lug connections, chafing protection, and cable ties.
Generator Control Cables	Starboard side of generator set alongside generator	Loosen cable ties as necessary. Monitor cables during jacking operation to ensure that slack exists.
Emergency Fuel Oil Stop Cables	From the mess deck to the emergency COV near the Raycor Filters	Monitor cables during jacking operation to ensure that slack exists.
Grounding Straps	Outbd fwd and inboard aft	Remove grounding straps prior to moving engine. (2 per engine).
Fuel Filter Assembly	Inboard aft side	RACOR filters must be removed to provide easier access to aft inboard mount. Disconnect RACOR filter assembly foundation by unbolting filter mounting bracket and disconnecting pipe connections. No pipe modifications are required and all three filters can be reinstalled after mount work.

NOTE

All welding on the deck for new after cooler and jacket water heat exchangers will occur prior to pouring of Chockfast® dams as welding may cause deck to deflect.

3.7 Raise the SSDG. The Contractor shall remove the nuts and remove the skid mounting bolts for each engine. Identify bolts/nuts to allow for renewal in kind upon reassembly. After new bolt/nuts are installed old bolt/nuts may be scrapped.

3.7.1 Develop a plan for lifting SSDG and present to COR 48 hours prior to lift for review. Plan shall be sensitive to lifting in such a way as to not deform deck plating that is not designed or reinforced to carry heavy load. The engines shall be raised 3". This will equate to a distance of approximately 190.4mm or 7.496" between the generator's frame rails and the deck (foundation).

NOTE

It is believed a 3” lift will be the minimum required to perform work. The higher the SSDG is lifted the greater problems with interferences and connections become. If Contractor believes 3” is inadequate to perform work, submit CFR with new recommended height along with supporting information.

3.7.2.1 At least four low-clearance (less than 5.5 inch) hydraulic jacks of at least 5-ton capacity shall be used to lift the generator set. These jacks should be connected to two pumps, the two forward jacks attached to one pump and the two aft jacks attached to the second pump. Each jack must have its own isolation valve. The jacks should be located about 40-½ inches (B Class) fore and aft of the center of the middle mounts. This will provide a basically balanced load on each of the jacks. Install dial indicators at all four corners the generator set. Jacks shall be used with doubler plates to distribute loading on the deck and prevent deck deflection. The dial indicators should be installed so as to monitor the upward motion of the engine (relative to the below- mount ship structure). They should be monitored throughout the jacking process to ensure the engine is lifted evenly all around. Steps should be taken to ensure that the generator foundation remains coplanar through the entire excursion within 1/16” (0.0625”). This can be done by using an Excel spreadsheet to record the heights at each stopping point and calculating the slopes between all the corner points to make sure that the set has risen evenly. Monitor the engine’s upward motion with the dial indicators, ensuring that the engine raises evenly all around. Stop after reaching slightly more than 3 inches of vertical displacement. It may be necessary to close off either the forward or aft set of valves and then continue pumping to level the generator set based on the dial indicator readings. When this lift is achieved, hardwood blocking shall be placed under the generator frame, spanning the generator rails and beyond to the longitudinal girders. Blocks and wedges shall be installed incrementally during the lift to ensure any failures of lifting manifold do not put strain on the foundation.

3.8 Remove existing mounts and Chockfast® Orange, or equivalent. The Contractor shall remove the existing vibration mounts.

3.8.1 Remove and discard mounting bolts, drawing shows head of mounting bolt tack welded in place. Other installations show the bolts were not tack welded.

3.8.2 Chip out and remove the existing Chockfast® Orange, or equivalent resin foundations.

3.8.3 Remove the metal Chockfast® Orange, or equivalent dams currently on doubler plates under each mount. Remove flush to allow new foam Chockfast® Orange, or equivalent dams to be mounted in their place directly on the doubler plate.

NOTE

This work will be performed prior to lowering the generator foundation onto the new mounts.

3.9 Prepare foundations. The Contractor shall clean the entire engine/generator foundation (ship structure e.g. decking, doubler plates, etc.) under the generator using emulsion or alkaline cleaners in accordance with SSPC-SP 1, to remove all oil, grease, dirt, debris, chemicals, and rust to provide a good clean surface for paint. This foundation does not include the skids.

NOTE

Do not coat the resilient element portions of the mounts with paint before or after installation.

3.10 Touch-up preservation, foundations. The Contractor shall prepare and coat all new and disturbed exterior and interior surfaces, as applicable, to match existing adjacent surfaces in accordance with SFLC Std Spec 6310, paragraph 3.1.13 (Touch-ups and minor coating repairs.)

3.11 Level SSDG, fabricate and install mounts. The Contractor shall level each SSDG in accordance with the attached Christie & Grey drawing and procedures, and the following steps:

3.11.1 The six new soleplates are provided GFE and depicted in attached drawing.

3.11.2 Provide and have ready 2 new mounting bolts, nuts and washers, for each mount. Drawing shows existing bolts are Gr 8 HEX HD 3/4" x 10UNC x 3-3/4" Long. Contractor shall examine a removed bolt and knowing the existing Chockfast® Orange, or equivalent thickness and existing thread engagement through nut determine length of longer bolts that are required.

3.11.3 To install the new mounts the required space between the frame and the foundation for the mount, sole plate and "Chockfast Orange" minimum clearance is ~190.4mm or 7.496".

3.11.4 Ensure all four jacking bolts are set to extend 0.500 inches below the sole plate. Install mounts and sole plates with the fasteners hand tight and foundation bolts in place and loose to the underside of the skid. Square the mounts to bottom of the generator. Slowly lower the SSDG skid on a level plane using hydraulic jacks while monitoring jacking screws. When the first jacking screw comes in contact with the deck, stop lowering evolution and adjust all other jacking screws to be in contact with the deck. Ensure all jacking screws are in contact with the deck and mounts have remained square to the generator frame. Ensure all jacking screws are in contact with the foundation. After checks of each of the four jacking screws (of all six mounts) check mount heights (should be original height and have no compression) and ensure that you have adequate clearance below the sole plates at all points for minimum Chockfast Orange pour 1/2" clearance. Provide a copy of sole plate clearances (at each corner-24 readings total) retake SSDG four corner reference point readings previously recorded prior to lift. Submit results in CFR.

3.11.5 When the readings are confirmed acceptable, slowly release the jacks keeping in mind your flexible fluid coupling allowable movements and transfer the load to the mounts positioned on the 4 jacking screws. Measure mount heights following instructions of Christie & Grey Data Sheet DS 094 (attached) after weight transfer. Ensure they are within compliance of Christie & Grey Data Sheet DS 096 (attached). Provide copy of post transfer mount heights to Christie & Grey. Once again retake SSDG four corner reference point readings previously recorded prior to lift. (to ensure no shift occurred when load was taken on jacking bolts) Submit results in CFR.

3.11.6 Wait 48 hours for initial settlement. By taking reading and then waiting 48 hours you can also look for signs of uneven settlement associated with soft foundations. Provide a copy of these new mount height readings in CFR.

3.11.7 When the final measurements are approved, prepare for the new Chockfast® Orange, or equivalent pour. Construct dams between to doubler plate and the soleplate to contain the Chockfast® Orange, or equivalent pour at each mount. Follow the attached literature from Chockfast orange concerning the

USCGC ALDER (WLB-225B) DOCKSIDE AVAILABILITY FY2020

installation as well as contact Chockfast® Orange, or equivalent directly from additional information and guidance.

NOTE

The mounts are being provided as GFE. The new isolation mounts are described in CG Dwg 225B-WLB 180-010. The new mounts are manufactured by Christie and Grey and will be pre-adjusted to the engine load. Contact point for parts and technical assistance is: Matthew Coombs (888) 472-8290; Christi & Grey Inc. E-mail: matthew.coombs@christiegrey.com A contact point for Christie & Grey is Patrick Bergen. 011-44-1732-371100. E-mail contact is sales@christiegrey.com.

3.11.8 Each SSDG has six (6) vibration mounts, a total of 3 per side. Four TSC T2 20/45 and two TSC T2 20/55 are provided GFE.

3.11.9 The TSC T2 20/55 at the engine front shall be installed with the label plates facing forward. The TSC T2 20/45 mounts at the middle position shall be installed with the label plate facing to port and starboard of the engine on their respective sides. The TSC T2 20/45 mounts in the aft position shall be installed with the label plates pointing forward.

3.11.10 Exercise care to avoid warping the foundations. Visually check the condition of the foundations to ensure no deformation of the foundations or the supporting structure has occurred. Submit a Condition Found Report (CFR).

3.11.11 Use release agent on mounting bolts, jacking bolts, and temporary foam pour walls, to allow for their eventual removal.

3.11.12 Snug up (do not torque) the two mounting bolts of each vibration mount, then conduct the six Chockfast® Orange, or equivalent pours (six mounts per SSDG)

3.11.13 After the resin compound has attained its cured strength (24-48 hrs depending on heat, 24 hrs with heat), remove temporary foam dam walls. Inspect the Chockfast® Orange, or equivalent pour ensuring there are no pockets (air gaps) observable.

3.11.14 Finally, remove all jacking and temporary supports from SSDG (including jacking bolts). Remove and then reinstall and final torque the mounting bolts. Gr 8 HEX HD ¾" x 10UNC bolts are to be torqued 376 ft-lbs when plain (un-lubricated) and when lubricated torqued to 188 ft-lbs.

3.12 Engine reassembly. The Contractor shall reinstall the SSDG components, piping & hoses, and insulation. Reconnect all fuel, lube, water and exhaust connections to each main diesel engine. Reconnect any wiring that was required to be removed and ensure all cable ties and chafing protection is restored

3.12.1 Submit a CFR for any service connection with the exception of the exhaust system that is unsatisfactory for reconnection due to any height difference of the SSDG. Coast Guard only anticipates that the exhaust connection will require modification and that work is specified in below paragraphs. Any other service connection modifications deemed necessary may be the subject to a contract change.

NOTE

Allow new resilient mounts to settle for at least 48 hours before reinstallation of any lines and completion of the final alignment.

USCGC ALDER (WLB-225B) DOCKSIDE AVAILABILITY FY2020

3.12.2 Fill the engine cooling system with Caterpillar ELC coolant.

3.12.3 Upon completion of installation and in the presence of the CG Inspector, top off the SSDG assemblies lube oil system with lube oil from the ship's lube oil storage tank. Verify lube oil levels prior to operating engine. Top off the jacket water system.

3.12.4 Fill the diesel engines with lube oil from ship's stores. 66 gallons of Delvav MX15W40 will be required for each SSDG. Deliver an equivalent quantity of lube oil of the same type to the ship to restore lube oil supplies aboard the cutter.

3.12.5 Take and record air gap readings on the generator. Compare these readings to the initial readings to ensure that there has been no significant change.

3.12.6 Epoxy a stamped plate in the vicinity of one of the TSC T2 mounts that gives the date the mounts were replaced. The plate should be located in a readily observed location, but protected enough that it will not be inadvertently knocked off.

3.12.7 Re-install electrical grounding straps between the above-mount engine and the below-mount foundation.

NOTE

If grounding straps were not installed previously, submit a CFR and a contract change will be negotiated for new grounding straps to be fabricated and installed.

3.13 Final pre-operation SSDG mount check & shimming. After final assembly and fluid fills, the Contractor shall allow each engine to sit on the mounts for at least 48 hours prior to final mount measurements.

3.13.1 Shim and align the engine to the limits given in the attached documents.

3.13.2 Measure and record the height of each vibration mounts at each of the four corners (Christie & Grey Data Sheet DS 096). The heights are expected to be equal at each isolator indicating it is parallel. Since new mounts have been installed, these readings may not match the old readings, but should be of similar magnitude. Record the data in a copy of the attached data sheet (found as enclosure at end of specification) for each SSDG. Measurements will be witnessed by the COR.

3.13.3 For information from review of literature it is expected the mounts unloaded are 165mm in height, after loaded (supporting the SSDG) they are expecting to be 158mm in height, after 48 hours and additional 1mm of creep may be observed (bringing height to 157 mm). Typically the height may be reduced an additional 5mm over their expected 8-10 year lifespan.

NOTE

When the new vibration mounts are installed sitting on a Chockfast® Orange, or equivalent base, the Coast Guard anticipates that the engine height relative to the exhaust system will change.

3.14 Exhaust system height correction. The Contractor shall measure and record the height difference between the engine exhaust and the expansion bellows as it hangs free. Compare this height difference to the original height difference measured.

USCGC ALDER (WLB-225B) DOCKSIDE AVAILABILITY FY2020

3.14.1 Remove lagging blankets from the engine exhaust system as required to modify the exhaust system.

3.14.2 Crop the exhaust system as required and adjust the height of the exhaust system to match the original height differential between the engine exhaust and the bellows joint. Demonstrate that the new height difference matches the previous height difference to the Coast Guard Inspector. On a previous Cutter performing work, the exhaust elbow on engine was modified and additional exhaust piping changes were not required.

3.14.3 Realign the exhaust system to prevent breakage of the flex coupling. Available adjustments include four flex mounts supporting the weight of the stack at the very top, and a number of pipe guides. The flex mounts can be adjusted just by turning the nuts to a higher position and relocking them.

3.14.4 If the engine when reconnected to the bellows has a vertical offset the pipe guides will need to be modified. Cut the guides off, raise, and re-weld as required to eliminate offset.

3.14.5 Reconnect the expansion bellows using new Contractor furnished supplied gaskets.

3.14.5.1 The following CAT parts apply:

- Gasket, 4(ea) required 5L-3773
- Bolt, 32(ea) required, 0S-1571
- Nut, 32(ea) required, 9S-8752

3.14.6 Reinstall the lagging blankets.

3.15 Acceptance testing. The Contractor shall perform the following tests:

3.15.1 Operability Test – Cycle each new component affected by this work item to verify operability. Verify that check, globe, and relief valves are installed in the proper flow orientation.

3.15.2 Clearance Check – For new equipment installed by this work item, open all doors to verify adequate servicing access and interference free operation. Similarly, verify that access to existing nearby equipment is not adversely affected by the new installation.

3.15.3 Operational Test – Verify proper operation of the components or systems affected by this work. During this testing, run the equipment through its full range of capabilities in all configurations and operating modes.

3.15.3.1 Test operate each of the SSDGs for a period of 2 hours. Use ship's electrical load to provide test resistance for the generators. A load bank is not required. Verify that the generators operate properly.

NOTE

These readings will be performed after the test operation of the SSDGs and after the engines have been allowed to cool.

3.16 Post operation SSDG mount measurements. The Contractor shall allow each engine to sit on the mounts for at least 48 hours prior to conducting alignment. Measure and record the height of each vibration mounts at each of the four corners (Christie & Grey Data Sheet DS 096). The heights are expected to be equal at each isolator indicating it is parallel. Since new mounts have been installed, these

USCGC ALDER (WLB-225B) DOCKSIDE AVAILABILITY FY2020

readings may not match the old readings, but should be of similar magnitude. Record the data in a copy of the attached data sheet (found as enclosure at end of specification) for each SSDG. Measurements will be witnessed by the COR.

3.16.1 For information from review of literature it is expected the mounts unloaded are 165mm in height, after loaded (supporting the SSDG) they are expecting to be 158mm in height, after 48 hours and additional 1mm of creep may be observed (bringing height to 157 mm). Typically the height may be reduced an additional 5mm over their expected 8-10 year lifespan.

3.17 Used mounts. The Contractor shall clean the old mounts free of any grease and oil. Pack the old mounts for shipment and turn over to the COR.

4. NOTES

4.1 General information ship's service diesel engine mounts. Each ship's service diesel generator is held in place by six (6) Christie & Grey Model T2.S20.45.C0.100-TSC-T2-20/45 engine mounts. Some ship's service diesel generators may have been fitted with a seventh experimental mount (in that case it will not be replaced, since new install only uses six). The engine mounts are placed in a Chockfast® Orange, or equivalent surface and the engine is bolted to the engine mounts. Photographs of typical SSDG engine mounts (from another ship of this class) are attached below.

4.2 Manufacturer information. Attached below are guidance in installing the new engine mounts. These documents are listed below:

- Christie & Grey Data Sheet DS 094 - Instructions for the measurement of mounting heights using either spring loaded telescopic gauges or a digital DTI set.
- Christie & Grey Data Sheet DS 096 - Mount Height Data Collection Sheet for New Installations and In Service Maintenance Checks - Marine Diesel Engines.
- Christie & Grey Drawing No. 44560 Isolation of Caterpillar 3508 Generator Set
- Chockfast® Orange, or equivalent, general Guidelines for Marine Chock Designers Bulletin No. 692D



SSDG
ISOLATION
MOUNTS





SSSD ISOLATION MOUNT



SSDG ISOLATION MOUNT

Q C F S 9 I S S U E 2

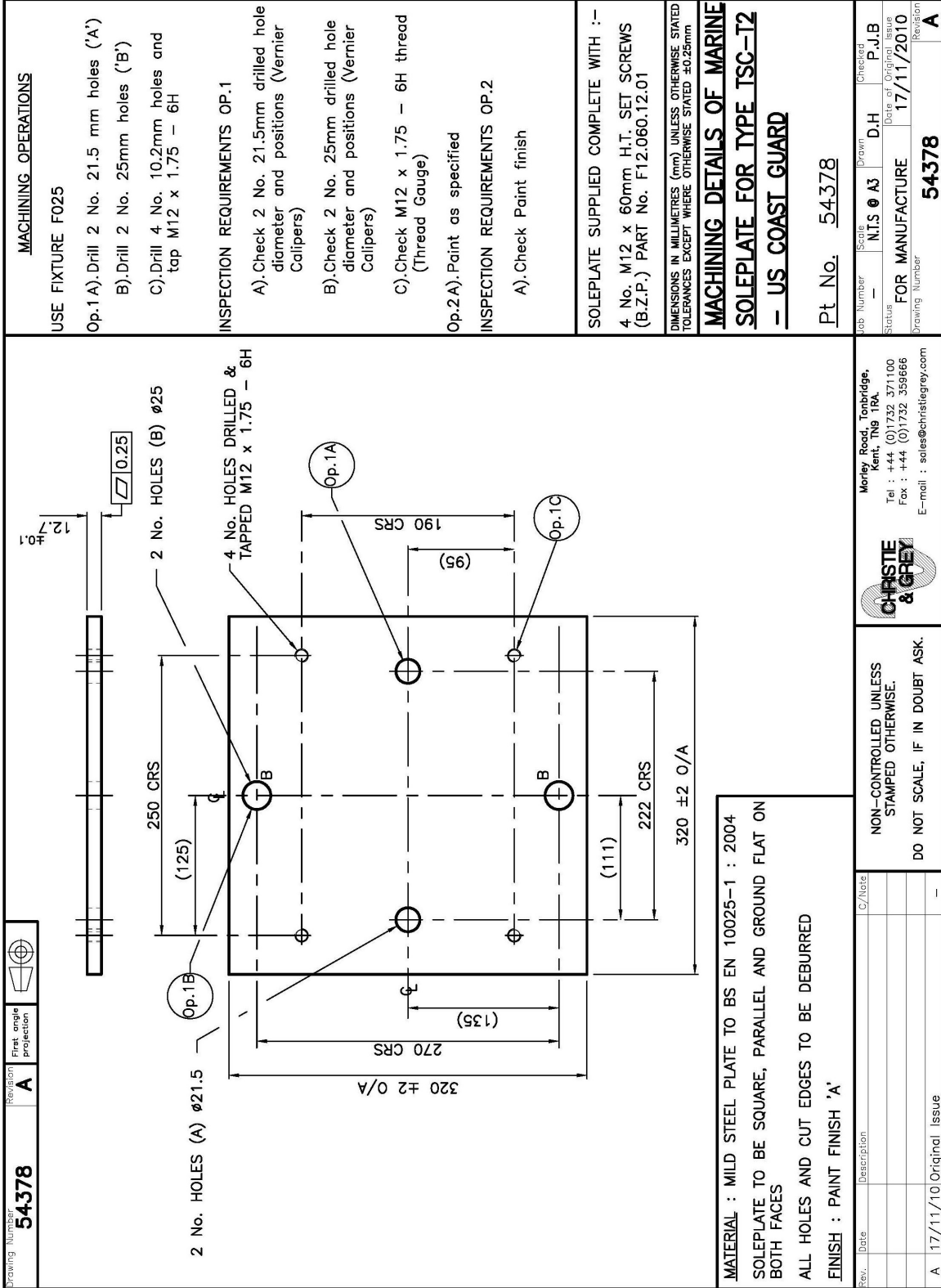

MACHINING OPERATIONS

USE FIXTURE F025

Op.1 A).Drill 2 No. 21.5 mm holes ('A')

B).Drill 2 No. 25mm holes ('B')

C).Drill 4 No. 10.2mm holes and tap M12 x 1.75 – 6H

INSPECTION REQUIREMENTS OP.1

A).Check 2 No. 21.5mm drilled hole diameter and positions (Vernier Calipers)

B).Check 2 No. 25mm drilled hole diameter and positions (Vernier Calipers)

C).Check M12 x 1.75 – 6H thread (Thread Gauge)

Op.2A).Paint as specified

INSPECTION REQUIREMENTS OP.2

A).Check Paint finish

SOLEPLATE SUPPLIED COMPLETE WITH :-

4 No. M12 x 60mm H.T. SET SCREWS (B.Z.P.) PART No. F12.060.12.01

DIMENSIONS IN MILLIMETRES (mm) UNLESS OTHERWISE STATED TOLERANCES EXCEPT WHERE OTHERWISE STATED ±0.25mm

MACHINING DETAILS OF MARINE SOLEPLATE FOR TYPE TSC-I2 – US COAST GUARD

Pt No. 54378

Job Number	Scale	Drawn	Checked
–	M1S @ A3	D.H	P.J.B
Status	Date of Original Issue		Revision
FOR MANUFACTURE	17/11/2010		A
Drawing Number	54378		

Drawing Number	Revision	First angle projection
54378	A	

MATERIAL : MILD STEEL PLATE TO BS EN 10025-1 : 2004

SOLEPLATE TO BE SQUARE, PARALLEL AND GROUND FLAT ON BOTH FACES

ALL HOLES AND CUT EDGES TO BE DEBURRED

FINISH : PAINT FINISH 'A'

Rev.	Date	Description	C/Note
A	17/11/10	Original Issue	–

CHRISTIE & GREY

Morley Road, Tonbridge, Kent, TN9 1RA.
Tel : +44 (0)1732 371100
Fax : +44 (0)1732 359666
E-mail : sales@christiegrey.com

NON-CONTROLLED UNLESS STAMPED OTHERWISE.
DO NOT SCALE, IF IN DOUBT ASK.

- 3) Store the resin and hardener at 20°C to 25°C (68°F to 77°F) for at least 12 hours but preferably 24 hours prior to use. This ensures the best mixing and pouring viscosity and the longest working time.
- 4) Round all corners and edges that may penetrate the CHOCKFAST.
- 5) Align the machinery and pour the CHOCKFAST with the vessel afloat. If alignment is critical, an adjustment should be made in the alignment to compensate for a slight settling that may occur of approximately 0.001cm per 1.0 cm (0.001 inch per 1 inch) of chock height.
- 6) Drill all bolt holes from the equipment bedplate down through the foundation as required by the equipment manufacturer.
- 7) Clean all surfaces that will come in contact with the CHOCKFAST. Surfaces should be free from oil, grease, water, rust, burrs, slag and loose paint. A thin coat of primer is acceptable.

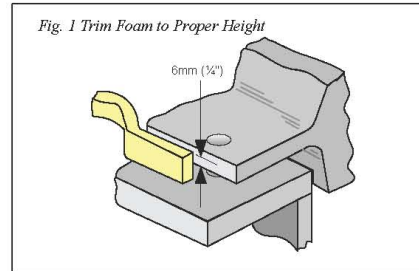

III. Damming

The picture sequence below shows the general procedure for damming a mounting foot. Each installation will be different so follow the dimensions shown on the Chocking Plan for your particular machine.

- 1) Trim the foam damming material to the proper height allowing for a 6 mm (1/4 inch) crush on the foam. (A bare hacksaw blade works best for this.) This amount of crush will allow for easy foam installation but still hold the foam firmly in place. When a closed cell foam is used such as neoprene, air vent tubes must be glued intermittently along the top of the foam to allow the air to escape.
- 2) Insert the damming material under the equipment mounting plate and around the hold down bolts and jacking screws as described on your Chocking Plan. The foam damming material must be located on three sides of the chocks.
- 3) Seal the hold down bolts and bolt holes so they do not leak. If you remove the hold down bolts, insert tight-fitting wooden dowels into the holes. If the bolts are left in place, hand-tighten the nuts and wrap the bolt shank with Armaflex tubing. Coat whatever is used to core the hole with a heavy coating of non-melt grease.

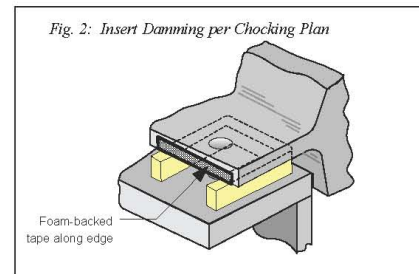

- 4) Fitted bolts should be sprayed with ITW Polymer Technologies' Release Agent then installed.
- 5) With the side dams in place and the bolt holes filled and coated, spray the chock area with Release Agent. See Fig. 3
- 6) Install a front metal dam so that the width and height will be within the limits shown in the drawing below. Install by gluing in place, small pieces of foam to allow the CHOCKFAST to be poured higher than the bottom of the mounting foot. The overpour area is very important as it provides both head pressure to the underside of the mounting foot and a pool of molten CHOCKFAST to feed the chock area if

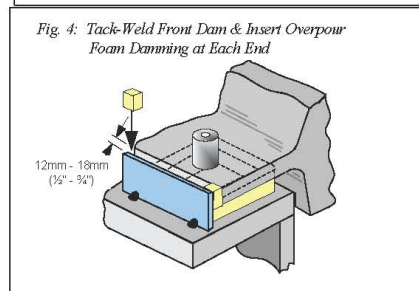
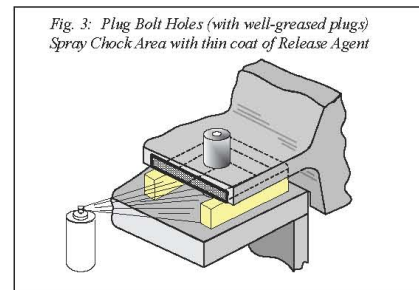

- needed. See Fig. 4
- 7) Make sure all potential leak points are well sealed. It is much easier to prevent leaks before the resin is poured in than to stop them afterwards.
 - 8) Spray the inside of the front metal dam with Release Agent so that it can easily be removed after the CHOCKFAST hardens. See Fig. 5.

IV Mixing And Pouring CHOCKFAST

- 1) Ensure that the damming completely surrounds the chock area and that there are no potential leak points.
- 2) Measure the chock thickness of each chock and the temperature of the engine bed and foundation. For CHOCKFAST ORANGE **only**, determine based on the graph in Fig. 9, how much hardener to use. The amount is based on machinery foundation temperature and the thickness of the chock. See Fig 6.

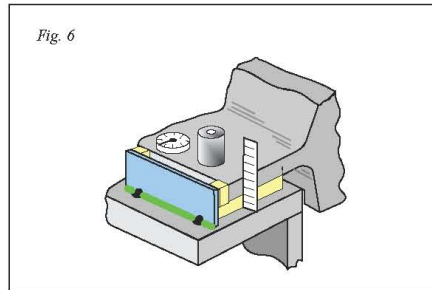

- 3) Bring out the resin and hardener from storage.
- 4) Installing CHOCKFAST is usually a team effort. Assign someone to each of the following jobs:
 - a) open the boxes of CHOCKFAST for the mixers,
 - b) add the hardener and time the mixing
 - c) mix the CHOCKFAST,
 - d) pour the CHOCKFAST and inspect for leaks.
 Make sure each member of the team knows their job and have a backup plan if any of the mixing equipment should fail.
- 5) Make sure everyone working with CHOCKFAST puts on gloves and eye protection.
- 6) Add hardener to the resin as needed. Power mix at about 200 RPM (never more than 500 RPM) for 3 minutes using a Jiffy Mixing blade or equal. The mixer should be comfortably seated to hold the can of CHOCKFAST securely between the feet. Keep the blade submerged at all times and traverse the entire can. Make sure the bottom of the can is scoured. See Fig. 7.

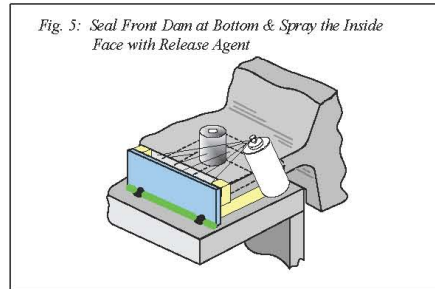

Fig. 5: Seal Front Dam at Bottom & Spray the Inside Face with Release Agent

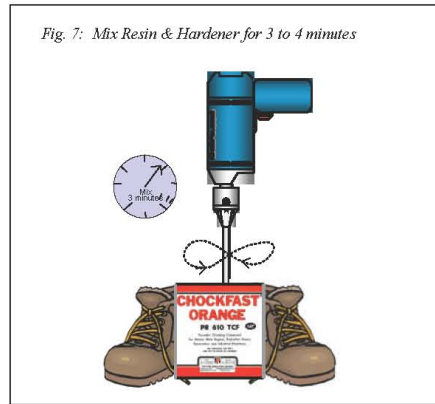

Fig. 7: Mix Resin & Hardener for 3 to 4 minutes

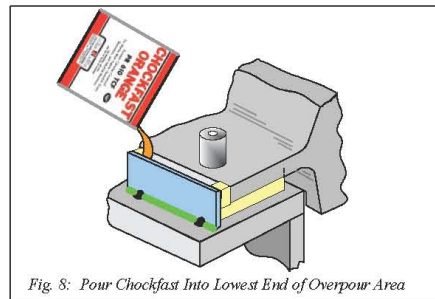
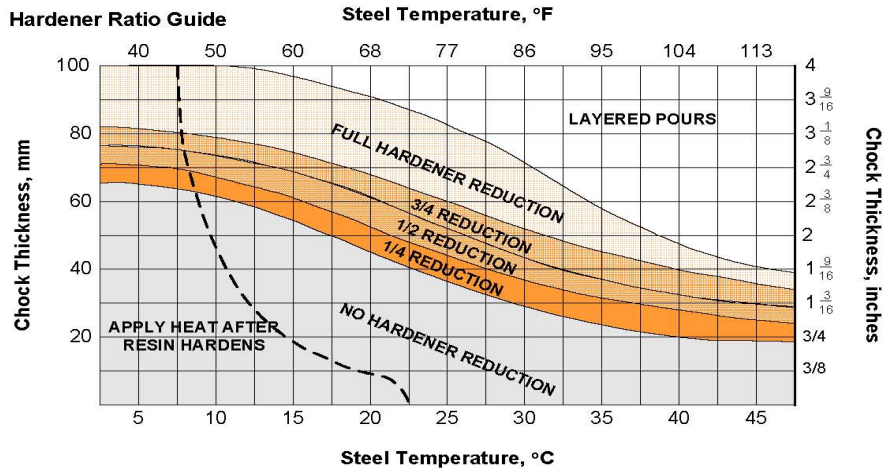

Fig. 8: Pour Chockfast Into Lowest End of Overpour Area

Fig.9 Hardener Ratio Guide





V After Pouring

- 1) Pour the resin as soon as possible after mixing. Do not scrape the residue from the can sides or bottom. Always pour from the lowest corner of the chock. Fill from a single point only so that air can escape as you fill. Pour as high above the chock as possible so that there is a thin ribbon of CHOCKFAST going into the chock. This forces any trapped air out of the liquid.
- 2) After Pouring Release the jack screws, alignment wedges or other alignment support devices.
- 3) In order for CHOCKFAST to cure, the temperature must be at least 13°C (55°F). Use heaters if necessary to bring the area up to at least this temperature. Length of cure will depend on temperature as follows:

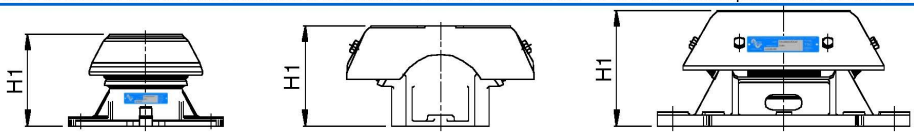

13°C–18°C (55°F–65°F)	48 hours
19°C–21°C (66°F–70°F)	24 hours
Above 21°C (70°F)	18 hours
- 4) When curing is complete, remove heaters and allow the CHOCKFAST to return to ambient temperature.
- 5) Remove the front dams and grind off the sharp edges of the overpour.
- 6) Tighten the hold down bolts to the desired tension.

Reference	For design considerations and application details please request Bulletin No. XXX or contact ITW Polymer Technologies' Engineering Services Department.
Date	08/2005

USCGC ALDER (WLB-225B) DOCKSIDE AVAILABILITY FY2020

TECHNICAL DATA SHEET		QCF 56 Issue 3																																																																																																																							
DS096		PAGE	1 of 2																																																																																																																						
		ISSUE	3																																																																																																																						
		DATE	14 January 2014																																																																																																																						
NON CONTROLLED UNLESS STATED OTHERWISE		APPROVED	PJB																																																																																																																						
TITLE	MOUNT HEIGHT DATA COLLECTION SHEET FOR NEW INSTALLATIONS AND IN SERVICE MAINTENANCE CHECKS - MARINE DIESEL ENGINES																																																																																																																								
Customer:		Engine Make:																																																																																																																							
Project:		Engine Model/Type:																																																																																																																							
C&G Drawing/Calculation #:		Engine Serial Number:																																																																																																																							
Date:		Engine Rotation:	<i>When viewed from flywheel end</i>																																																																																																																						
Prepared by:		Position in Vessel:																																																																																																																							
Application Type:																																																																																																																									
<p>All dimensions are in millimetres. Read in conjunction with DS094 to determine height H1 for the relevant TSC Model. Mount heights are to be recorded once the load is transferred to the mounts and for new installations after the 48 hour settlement period has been observed.</p>																																																																																																																									
																																																																																																																									
<table border="1" style="width:100%; border-collapse: collapse;"> <tr> <td style="width: 20%;"></td> <td style="width: 15%; text-align: center;">x2</td> <td style="width: 15%; text-align: center;">x1</td> <td style="width: 15%; text-align: center;">x2</td> <td style="width: 15%; text-align: center;">x1</td> <td style="width: 15%; text-align: center;">x2</td> <td style="width: 15%; text-align: center;">x1</td> <td style="width: 15%; text-align: center;">x2</td> <td style="width: 15%; text-align: center;">x1</td> <td style="width: 15%; text-align: center;">x2</td> <td style="width: 15%; text-align: center;">x1</td> </tr> <tr> <td style="text-align: center; vertical-align: middle;">FLYWHEEL</td> <td style="text-align: center;">L1</td> <td style="text-align: center;">L2</td> <td style="text-align: center;">L3</td> <td style="text-align: center;">L4</td> <td style="text-align: center;">L5</td> <td colspan="5"></td> </tr> <tr> <td></td> <td style="text-align: center;">x3</td> <td style="text-align: center;">x4</td> <td style="text-align: center;">x3</td> <td style="text-align: center;">x4</td> <td style="text-align: center;">x3</td> <td style="text-align: center;">x4</td> <td style="text-align: center;">x3</td> <td style="text-align: center;">x4</td> <td style="text-align: center;">x3</td> <td style="text-align: center;">x4</td> </tr> <tr> <td></td> <td style="text-align: center;">x4</td> <td style="text-align: center;">x3</td> <td style="text-align: center;">x4</td> <td style="text-align: center;">x3</td> <td style="text-align: center;">x4</td> <td style="text-align: center;">x3</td> <td style="text-align: center;">x4</td> <td style="text-align: center;">x3</td> <td style="text-align: center;">x4</td> <td style="text-align: center;">x3</td> </tr> <tr> <td></td> <td style="text-align: center;">R1</td> <td style="text-align: center;">R2</td> <td style="text-align: center;">R3</td> <td style="text-align: center;">R4</td> <td style="text-align: center;">R5</td> <td colspan="5"></td> </tr> <tr> <td></td> <td style="text-align: center;">x1</td> <td style="text-align: center;">x2</td> <td style="text-align: center;">x1</td> <td style="text-align: center;">x2</td> <td style="text-align: center;">x1</td> <td style="text-align: center;">x2</td> <td style="text-align: center;">x1</td> <td style="text-align: center;">x2</td> <td style="text-align: center;">x1</td> <td style="text-align: center;">x2</td> </tr> </table>					x2	x1	x2	x1	x2	x1	x2	x1	x2	x1	FLYWHEEL	L1	L2	L3	L4	L5							x3	x4	x3	x4	x3	x4	x3	x4	x3	x4		x4	x3	x4	x3	x4	x3	x4	x3	x4	x3		R1	R2	R3	R4	R5							x1	x2	x1	x2	x1	x2	x1	x2	x1	x2																																																				
	x2	x1	x2	x1	x2	x1	x2	x1	x2	x1																																																																																																															
FLYWHEEL	L1	L2	L3	L4	L5																																																																																																																				
	x3	x4	x3	x4	x3	x4	x3	x4	x3	x4																																																																																																															
	x4	x3	x4	x3	x4	x3	x4	x3	x4	x3																																																																																																															
	R1	R2	R3	R4	R5																																																																																																																				
	x1	x2	x1	x2	x1	x2	x1	x2	x1	x2																																																																																																															
<p>Identify your TSC model from the images above and from the mount name plate and then select it from the drop down list below. If your installation uses New Mounts select New Mounts from the drop down list below otherwise leave as Existing Mounts. Select your TSC Model: _____ Type of Installation: _____</p> <p>Enter the Mount Serial No's & measure and enter heights H1, for positions x1 through to x4 for each mount in your installation.</p> <p><i>Enter your mount data in the table below filling in only the yellow boxes.</i></p> <table border="1" style="width:100%; border-collapse: collapse;"> <thead> <tr> <th>Mount Position</th> <th>Mount Serial #</th> <th>x1 mm</th> <th>x2 mm</th> <th>x3 mm</th> <th>x4 mm</th> <th>Measurement Cross Check</th> <th>Average Mount Height mm</th> <th>Parallelism Check</th> <th>Commissioning Check</th> </tr> </thead> <tbody> <tr><td>L1</td><td></td><td></td><td></td><td></td><td></td><td></td><td></td><td></td><td></td></tr> <tr><td>L2</td><td></td><td></td><td></td><td></td><td></td><td></td><td></td><td></td><td></td></tr> <tr><td>L3</td><td></td><td></td><td></td><td></td><td></td><td></td><td></td><td></td><td></td></tr> <tr><td>L4</td><td></td><td></td><td></td><td></td><td></td><td></td><td></td><td></td><td></td></tr> <tr><td>L5</td><td></td><td></td><td></td><td></td><td></td><td></td><td></td><td></td><td></td></tr> <tr><td>R1</td><td></td><td></td><td></td><td></td><td></td><td></td><td></td><td></td><td></td></tr> <tr><td>R2</td><td></td><td></td><td></td><td></td><td></td><td></td><td></td><td></td><td></td></tr> <tr><td>R3</td><td></td><td></td><td></td><td></td><td></td><td></td><td></td><td></td><td></td></tr> <tr><td>R4</td><td></td><td></td><td></td><td></td><td></td><td></td><td></td><td></td><td></td></tr> <tr><td>R5</td><td></td><td></td><td></td><td></td><td></td><td></td><td></td><td></td><td></td></tr> </tbody> </table> <p>Once you have entered your readings, they are checked and verified. Please contact our Technical Department if you have any questions.</p> <p style="text-align: center;"><i>Please enter your contact details below:</i></p> <table border="1" style="width:100%; border-collapse: collapse;"> <tr> <td>Name:</td> <td></td> <td>Email:</td> <td></td> </tr> <tr> <td>Tel No:</td> <td></td> <td>Date:</td> <td></td> </tr> </table>				Mount Position	Mount Serial #	x1 mm	x2 mm	x3 mm	x4 mm	Measurement Cross Check	Average Mount Height mm	Parallelism Check	Commissioning Check	L1										L2										L3										L4										L5										R1										R2										R3										R4										R5										Name:		Email:		Tel No:		Date:	
Mount Position	Mount Serial #	x1 mm	x2 mm	x3 mm	x4 mm	Measurement Cross Check	Average Mount Height mm	Parallelism Check	Commissioning Check																																																																																																																
L1																																																																																																																									
L2																																																																																																																									
L3																																																																																																																									
L4																																																																																																																									
L5																																																																																																																									
R1																																																																																																																									
R2																																																																																																																									
R3																																																																																																																									
R4																																																																																																																									
R5																																																																																																																									
Name:		Email:																																																																																																																							
Tel No:		Date:																																																																																																																							
 <p>Christie & Grey Limited Morley Road, Tonbridge, Kent TN9 1RA, England Telephone : +44 (0) 1732 371100 • Fax : +44 (0) 1732 359666 E-mail : sales@christiegrey.com • web site : www.christiegrey.com</p> 																																																																																																																									

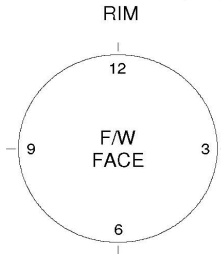
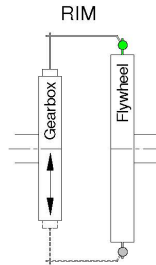
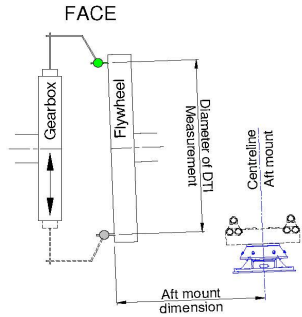
USCGC ALDER (WLB-225B) DOCKSIDE AVAILABILITY FY2020

TECHNICAL DATA SHEET		QCF 56 Issue 3																					
DS096		PAGE	2 of 2																				
NON CONTROLLED UNLESS STATED OTHERWISE		ISSUE	3																				
		DATE	14 January 2014																				
		APPROVED	PJB																				
TITLE	MOUNT HEIGHT DATA COLLECTION SHEET FOR NEW INSTALLATIONS AND IN SERVICE MAINTENANCE CHECKS - MARINE DIESEL ENGINES																						
Instructions																							
<p>Mount Heights are determined by measuring the four corners of the mount as shown in technical data sheet DS094. The following formulas can be used complete page 1 of form DS096 by hand.</p> <p>Cross Check for errors: $(x1 + x3) - (x2 + x4) =$ Measurement Cross Check This helps to see if your measurements make sense. The closer to zero the more accurate your readings. Ignore the "+" & "-" signs, you want to be as close to zero as possible.</p> <p>Average Height: $(x1 + x2 + x3 + x4) \div 4 =$ Average Mount Height</p> <p>Delta is the difference between the high and low corner: Largest x - Smallest x = Parallelism You want the number as small as possible. Check your installation instructions for tolerances or ask C&G Technical Department for advice.</p> <p>Send us your completed readings sheet. We will always provide free technical support to review your numbers and provide advice and assistance in making adjustments.</p>																							
Coupling Alignment																							
<p>If you send us your Rim, Face, DTI Diameter & Aft mount measurements we can advise you on mount shimming if required.</p>																							
																							
		<p>In the example above the DTI is connected to the gearbox flange and the gearbox flange rotated to take the measurements.</p> <p>It is important to rotate the component that the DTI is connected to.</p>																					
<table border="1" style="width: 100%; border-collapse: collapse;"> <thead> <tr> <th style="width: 25%;">Position</th> <th style="width: 15%;">Angle</th> <th style="width: 25%;">Rim Measurement</th> <th style="width: 35%;">Face Measurement</th> </tr> </thead> <tbody> <tr> <td>12 o'clock</td> <td>0°</td> <td></td> <td></td> </tr> <tr> <td>3 o'clock</td> <td>90°</td> <td></td> <td></td> </tr> <tr> <td>6 o'clock</td> <td>180°</td> <td></td> <td></td> </tr> <tr> <td>9 o'clock</td> <td>270°</td> <td></td> <td></td> </tr> </tbody> </table>				Position	Angle	Rim Measurement	Face Measurement	12 o'clock	0°			3 o'clock	90°			6 o'clock	180°			9 o'clock	270°		
Position	Angle	Rim Measurement	Face Measurement																				
12 o'clock	0°																						
3 o'clock	90°																						
6 o'clock	180°																						
9 o'clock	270°																						
<table border="1" style="width: 100%; border-collapse: collapse;"> <tbody> <tr> <td style="width: 70%;">Measurement Units (mm/inches)</td> <td></td> </tr> <tr> <td>Diameter of DTI Face Measurement</td> <td></td> </tr> <tr> <td>Centre line Aft mount dimension</td> <td></td> </tr> </tbody> </table>				Measurement Units (mm/inches)		Diameter of DTI Face Measurement		Centre line Aft mount dimension															
Measurement Units (mm/inches)																							
Diameter of DTI Face Measurement																							
Centre line Aft mount dimension																							
<p>Fax your readings to (508) 217-3061 (USA) or +44 (0) 1732 359666 (U.K.) or e-mail your readings to: matthew.coombs@christiegrey.com (USA) or sales@christiegrey.com (U.K.)</p> <p>Please contact our Technical Department if you have any questions.</p>																							
<i>Please enter your contact details below:</i>																							
Name:		Email:																					
Tel No:		Date:																					
<div style="display: flex; justify-content: space-between; align-items: center;"> <div style="text-align: center;">  </div> <div> <p>Christie & Grey Limited Morley Road, Tonbridge, Kent TN9 1RA, England Telephone : +44 (0) 1732 371100 • Fax : +44 (0) 1732 359666 E-mail : sales@christiegrey.com • web site : www.christiegrey.com</p> </div> <div style="text-align: center;">  </div> </div>																							

USCGC ALDER (WLB-225B) DOCKSIDE AVAILABILITY FY2020

TECHNICAL DATA SHEET DS 094 NON CONTROLLED UNLESS STATED OTHERWISE	QCF 56 Issue 3	
	PAGE	1 of 3
	ISSUE	6
	DATE	14 January 2014
	APPROVED	PJB

TITLE. Instructions for the measurement of mounting heights using either spring loaded telescopic gauges or a digital DTI set.

**This instruction is to be read in conjunction with Data Sheet DS071
Instructions for the Measurement of Mounting Heights.**

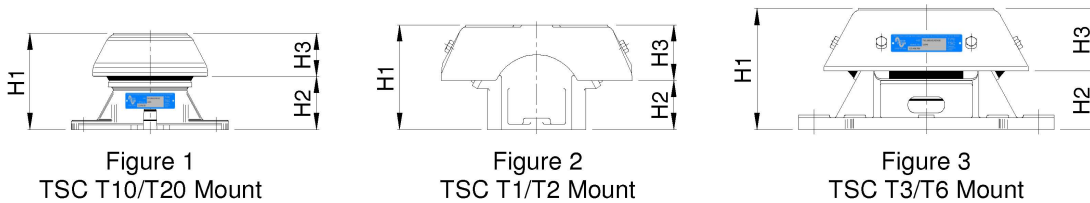

Table 1.

MODEL	COMMISSIONED HEIGHT H1	COMMISSIONED HEIGHT H2	MINIMUM HEIGHT H1	MINIMUM HEIGHT H2	HEIGHT H3 ±0.2mm	TELESCOPIC GAUGE or DTI MEASUREMENT RANGE
TSC T1	Greater than 153mm	From 2011 onwards only Greater than 68mm	151mm	From 2011 onwards only 66mm	85mm	54mm to 89mm
TSC T2	Greater than 158mm	From 2011 onwards only Greater than 73mm	156mm	From 2011 onwards only 71mm	85mm	54mm to 89mm
TSC T3 IRON Mk 3 TYPE	Greater than 175mm	From 1996 onwards only Greater than 79.4mm	171mm	From 1996 onwards only 75.4mm	95.6mm	90mm to 150mm
TSC T3 ALUMINIUM	Greater than 175mm	From 1996 onwards only Greater than 82.5mm	172mm	From 1996 onwards only 79.5mm	92.5mm	90mm to 150mm
TSC T3 Mixed ALY BASE/IRON TOP	Greater than 175mm	From 1996 onwards only Greater than 79.4mm	171mm	From 1996 onwards only 75.4mm	95.6mm	90mm to 150mm
TSC T6	Greater than 170mm	Greater than 74.4mm	167mm	71.4mm	95.6mm	90mm to 150mm
TSC T10 / TSC T20	Greater than 137mm	From 2012 onwards only Greater than 74.6mm	134.5mm	From 2012 onwards only 72.1mm	62.4mm	54mm to 89mm



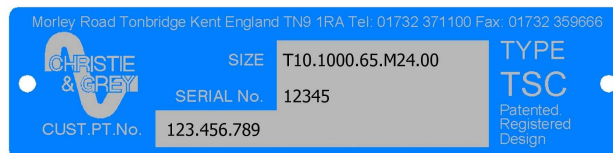

Note! If measuring overall height H1 it is the actual mount height that has to be measured and does not include resin grout, soleplates, proof plates or shims.

Prior to taking height measurements.

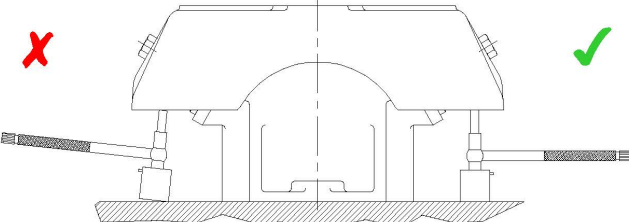
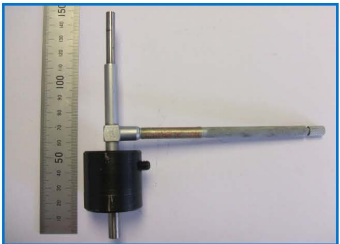
- A. Identify and record serial number from mount name plate. Typical name plate shown here.
- B. Note mount position in relation to machine orientation e.g. from flywheel end.
- C. For TSC T3 mounts from 1996, TSC T1/T2 mounts from 2011 and TSC T10/T20 mounts from 2012, top casting skirts are machined to simplify measurement of height H2. If you are unsure about which model you have, please contact our Technical Department for advice stating the mount serial no's.
- D. When using spring loaded telescopic gauges refer to Method 1 on page 2 or if using a digital DTI set refer to Method 2 on page 3.

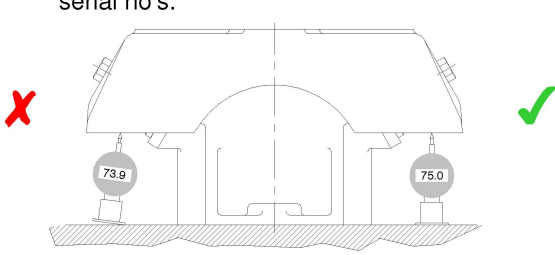

TECHNICAL DATA SHEET DS 094 NON CONTROLLED UNLESS STATED OTHERWISE		QCF 56 Issue 3	
		PAGE	2 of 3
		ISSUE	6
		DATE	14 January 2014
		APPROVED	PJB
TITLE.	Instructions for the measurement of mounting heights using either spring loaded telescopic gauges or a digital DTI set.		
<p><u>Using Spring Loaded Telescopic Gauges.</u></p> <p>Measure mount height H2 where possible using a spring loaded telescopic gauge (see figures 4 & 5 below). Refer to table 1 on page 1 for heights and measurement range for gauges.</p> <ol style="list-style-type: none"> 1. Ensure datum measuring points are flat, clean and free from burrs and imperfections. 2. It is critical that measurements are taken perpendicular to the mounting seating face. For example, a two degree error in vertical alignment of the gauge will result in an error of 0.1 mm on a measured height of 150 mm. See figure 4 below. 3. Select a spring loaded telescopic gauge with suitable range for the gap to be measured, see table 1 on page 1. 4. Take four measurements equally spaced from the mount centreline at adjacent corners where possible. 5. Compress telescopic gauge and lock in compressed position. 6. Position gauge below mount and release gauge compression. 7. Apply light finger pressure to hold gauge in position against base support while tightening the gauge locking screws. 8. Carefully remove the gauge by twisting the base. 9. Measure the height of the spring loaded telescopic gauge using a micrometer, vernier callipers or if available a digital height gauge from a flat ground plate. 10. If any mounts are found to be at or below the minimum height (see table 1 on page 1) they are to be replaced. Please contact our Technical Department for advice stating the mount serial no's. 			
			
Figure 4		Figure 5	

TECHNICAL DATA SHEET DS 094 NON CONTROLLED UNLESS STATED OTHERWISE		QCF 56 Issue 3	
		PAGE	3 of 3
		ISSUE	6
		DATE	14 January 2014
		APPROVED	PJB
TITLE.	Instructions for the measurement of mounting heights using either spring loaded telescopic gauges or a digital DTI set.		
<p>Using a digital DTI set.</p> <p>Measure mount height H2 where possible using a digital DTI set (see figures 6 & 7 below). Refer to table 1 on page 1 for heights and measurement range for DTI set.</p> <p>Combination of interlocking machined shafts and support tubes fixed to digital DTI with a 13 mm plunger movement.</p> <p>Measurement range dependant upon combination is 125mm to 200mm (can be increased with manufacture of different length machined support).</p> <ol style="list-style-type: none"> 1. Ensure datum measuring points are flat, clean and free from burrs and imperfections. 2. It is critical that measurements are taken perpendicular to the mounting seating face. For example, a two degree error in vertical alignment of the DTI will result in an error of 0.1mm on a measured height of 150 mm. See figure 6 below. 3. Configure the set and lock off support tubes so that DTI plunger is at a known nominal height within mid range of gap to be measured. It should be noted that a height gauge and surface plate are the best practice for this purpose. 4. Take four measurements equally spaced from the mount centreline at adjacent corners where possible. 5. Position gauge below mount and apply light finger pressure to hold gauge in position against base support foot. Record the readings from the display (the DTI hold function can be used to store the readings whilst the gauge is being removed). 6. Add or subtract the DTI display reading to the nominal value. 7. Regularly check the DTI zero position to ensure it has not altered and adjust as necessary. 8. If any mounts are found to be at or below the minimum height (see table 1 on page 1) they are to be replaced. Please contact our Technical Department for advice stating the mount serial no's. 			
 <p>Figure 6</p>		 <p>Figure 7</p>	
		<p>Christie & Grey Limited Morley Road, Tonbridge, Kent TN9 1RA, England Telephone : +44 (0) 1732 371100 • Fax: +44 (0) 1732 359666 E-mail : sales@christiegrey.com • web site: www.christiegrey.com</p>	
			

WORK ITEM 11: Deck Covering, Electrical Matting, Renew

1. SCOPE

1.1 Intent. This work item describes the requirements for the Contractor to renew electrical matting as identified in Table 1.

TABLE 1 - DECKING SYSTEM PARTICULARS

LOCATION	AREA	DECK MTL	COVE BASE	SYSTEM COLOR	UNDERLAYMENT REQUIREMENT
EM Shop	140 sqft	Steel	YES #4 Vinyl	Specify color requested by the unit	Renew existing underlayment.
ECC	200 sqft	Steel	YES #4 Vinyl	Specify color requested by the unit	Renew existing underlayment.

1.2 Government-furnished property.

None.

2. REFERENCES

COAST GUARD DRAWINGS

Coast Guard Drawing 225-WLB-070-001, Rev G, Fire, Watertight Integrity & Hazardous Locations Plan

COAST GUARD PUBLICATIONS

Surface Forces Logistics Center Standard Specification 6341 (SFLC Std Spec 6341), 2018, Install Interior Deck Covering Systems

Surface Forces Logistics Center Standard Specification 0740 (SFLC Std Spec 0740), 2018, Welding and Allied Processes

OTHER REFERENCES

Federal Specification (Fed Spec) DDD-C-95, Mar 1972, Carpets and Rugs, Wool, Nylon, Acrylic, Modacrylic

3. REQUIREMENTS

3.1 General.

3.1.1 CIR. The Contractor shall submit a CIR for the inspections listed in the following paragraph(s):

- 3.3 Ultrasonic thickness (UT) measurement.

3.1.2 Tech Rep.

Not applicable

3.1.3 Protective measures. The Contractor shall furnish and install all protective coverings to seal off and protect all non-affected vessel's components, equipment, and spaces near the work area against contamination during the performance of work. Upon completion of work, the Contractor shall remove all installed protective measures, inspect for the presence of contamination, and return all contaminated equipment, components, and spaces to original condition of cleanliness.

3.1.4 Interferences. The Contractor shall handle all interferences in accordance with SFLC Std Spec 0000, paragraph 3.3.5 (Interferences).

- Computer Desk-ECC
- Deck Mounted Vidmars
- Parts organizer shelves

3.2 Renewal. The Contractor shall perform all tasks specified in SFLC Std Spec 6341 and herein, to install a new covering system in the location(s) specified in Table 1 below.

NOTE

Insulation underlayment may be used to prevent condensation in certain areas - e.g., above ballast tanks and hot machinery spaces, especially where these decks form the deck tops of living spaces.

3.3 Ultrasonic thickness (UT) measurement. The Contractor shall take a total of 05 UT measurements in accordance with SFLC Std Spec 0740, Appendix C in each location designated by the Coast Guard Inspector and using Coast Guard Drawing Coast Guard Drawing 225-WLB-070-001, Rev G, Fire, Watertight Integrity & Hazardous Locations Plan as guidance. Submit a CIR.

3.4 Deck covering color. The Contractor shall submit a deck covering color chart to Coast Guard Inspector for the purpose of color selection.

4. NOTES

This section is not applicable to this work item.

WORK ITEM 12: Potable Water Pipe, Renew

1. SCOPE

1.1 Intent. This work item describes the requirements for the Contractor to renew the Potable Water Fill Pipe.

1.2 Government-furnished property.

None.

2. APPLICABLE DOCUMENTS

COAST GUARD DRAWINGS

Coast Guard Drawing 225B-WLB 532-2, Rev E, Potable Water System Diagram

COAST GUARD PUBLICATIONS

Surface Forces Logistics Center Standard Specification 0000 (SFLC Std Spec 0000), 2018, General Requirements

Surface Forces Logistics Center Standard Specification 0740 (SFLC Std Spec 0740), 2018, Welding and Allied Processes

OTHER REFERENCES

The Society for Protective Coatings (SSPC) Paint Application Specification No. 3 (SSPC-PA Guide 3), 1995, A Guide to Safety in Paint Application

The Society for Protective Coatings (SSPC) Surface Preparation Specification No.11 (SSPC-SP 11), 2004, Power Tool Cleaning to Bare Metal

3. REQUIREMENTS

3.1 General.

3.1.1 CIR.

None.

3.1.2 Protective measures. The Contractor shall furnish and install suitable covering to seal off and protect all non-affected surfaces/equipment and spaces in the vicinity of the work area against contamination during the performance of work. Upon completion of work, remove protective material

USCGC ALDER (WLB-225B) DOCKSIDE AVAILABILITY FY2020

and inspect for the presence of contamination. Clean all equipment and spaces, contaminated due to improper protection, to original condition of cleanliness.

3.1.3 Interferences. The Contractor shall be aware that interferences in way of work include, but are not limited to the below-listed. Handle all interferences in accordance with SFLC Std Spec 0000, paragraph 3.3.5 (Interferences):

- Ventilation ducting.
- Piping.
- Entertainment Center.
- Electrical wiring.
- Insulation, lagging.

3.2 Water Pipe Renew. The Contractor shall perform all tasks specified in SFLC Std Spec 074 and herein, to renew the water fill pipe in the locations specified in Coast Guard Drawing 225B-WLB 532-2.

3.2.1 Where possible, cut all edges along existing seams. Corners shall intersect plating seams at 90 degree angles. Corners that are not formed by designed plating seams shall have a minimum radius of, three inches, or one-eighth of the transverse dimension of the cut, whichever is greater.

3.2.2 Ensure that welding does not warp or cause any distortion to adjacent plating.

3.2.3 Work areas are in location Port side , Frame 17. See Coast Guard Drawing 225B-WLB 532-2 for more details.

3.3 Crop out and retain the pipe for used as templates in accordance SFLC Std Spec 0740.

3.4 Crop out and scrap approximately 5ft of water fill pipe and its associated hardware in accordance with SFLC Std Spec 0740 and Coast Guard Drawing 225B-WLB 532-2.

3.5 Install new pipe and its associated hardware with similar material type and size and according to Coast Guard Drawing 225B-WLB 532-2 (Detail 19-G, Note 20 and 21).

3.6 Weld Joint Inspections

3.6.1 In the presence of the Coast Guard Inspector, visually inspect and perform a magnetic particle test on 10% all new welds in accordance with AWS D1.1. Test acceptance standards shall be in accordance with AWS D1.1. Repair all weld deficiencies and retest.

3.6.2 Upon completion of all welding, perform a liquid film bubble emission test on all water tight boundaries (hull plating welds) in accordance with SFLC Std Spec 000.

3.7 Tank disinfecting. After all other work involving the potable water system and tank closing have been completed, the Contractor shall disinfect and treat the affected potable water tank(s) and associated disturbed piping and components, as necessary, to meet or exceed the requirements of AWWA C652. After tank disinfecting; remove and dispose of all treated water in accordance with all Federal, state and local regulations. Ensure that no one enters the tanks once disinfection is completed.

3.8 Surface Preparation – Upon completion of successful nondestructive testing, prepare all new and disturbed exterior areas in accordance with SSPC-SP 10. Prepare all new and disturbed interior areas in

USCGC ALDER (WLB-225B) DOCKSIDE AVAILABILITY FY2020

accordance with SSPC-SP 11. Feather the surrounding surfaces to obtain a 3-inch wide smoothly tapered boundary from the existing paint to the prepared surface.

NOTE

Where applicable, prepare all affected steel surfaces, including areas designated for UT inspections, to “bare metal” (SSPC-SP 11, with a minimum 1.0 mil anchor profile).

3.8.1 Prior to applying any paint, remove all dust, grease, oil, or other contaminants from all prepared areas in accordance with applicable local, state, and federal laws and regulations.

3.8.2 The Coast Guard Inspector will verify all surface preparation.

3.8.3 Upon verification from the Coast Guard Inspector on all surface preparation, prime and coat all prepared surfaces to match existing adjacent surfaces in accordance with the applicable sections of General Requirements. For surfaces to be covered with insulation, apply primer coats only.

3.9 Coat newly installed insulation in accordance with General Requirements.

3.10 Restore all interferences to their original condition in accordance with the General Requirements.

4. NOTES

This section is not applicable to this work item.

WORK ITEM 13: Potable Water Valves, Renew

1. SCOPE

1.1 Intent. This work item describes the requirements for the Contractor to renew the Hot Potable Water piping & valves on recirculation pumps #1 and #2.

1.2 Government-furnished property.

None.

2. APPLICABLE DOCUMENTS

COAST GUARD DRAWINGS

Coast Guard Drawing 225B-WLB 532-2, Rev E, Potable Water System Diagram

COAST GUARD PUBLICATIONS

Surface Forces Logistics Center Standard Specification 0000 (SFLC Std Spec 0000), 2018, General Requirements

Surface Forces Logistics Center Standard Specification 0740 (SFLC Std Spec 0740), 2018, Welding and Allied Processes

Surface Forces Logistics Center Standard Specification 6310 (SFLC Std Spec 6310), 2018, Requirements for Preservation of Ship Structures

OTHER REFERENCES

None.

3. REQUIREMENTS

3.1 General.

3.1.1 CIR.

None.

3.1.2 Protective measures. The Contractor shall furnish and install suitable covering to seal off and protect all non-affected surfaces/equipment and spaces in the vicinity of the work area against contamination during the performance of work. Upon completion of work, remove protective material and inspect for the presence of contamination. Clean all equipment and spaces, contaminated due to improper protection, to original condition of cleanliness.

USCGC ALDER (WLB-225B) DOCKSIDE AVAILABILITY FY2020

3.1.3 Interferences. The Contractor shall handle all interferences in accordance with SFLC Std Spec 0000, paragraph 3.3.5 (Interferences). Known interferences include, but are not limited to the below-listed:

- Piping.
- Deck drains.
- Insulation, lagging.
- Wiring.

3.1.4 Contamination prevention. The Contractor shall take all precautions to prevent contamination of personnel and spaces in accordance with all applicable Federal, state, and local regulations.

3.2 Fluid handling. The Contractor shall remove and dispose of removed fluids from the affected piping system, in accordance with all applicable Federal, state, and local regulations.

WARNING

Do not drain ANY fluids, including fresh water, into any space, bilge, or exterior location.

3.3 Piping renewal particulars. The Contractor shall renew part of the on potable water piping and valves (total 4 valves) using Coast Guard Drawings as guidance.

TYPE	SIZE (inches)	MAT'L	DESCRIPTION LOCATION	CONNECTION	RATED PRESSURE CLASS (#)
Gate	½	Brass	V101-9 V101-10	Welded	150
Gate	½	“	V101-11 V101-12	Welded	150

3.3.1 When and where necessary, fabricate and install new pipe hangers in way of the permanently discarded hangers in accordance with General Requirements. Remove any old discontinued pipe hangers no longer used.

3.3.2 Shop fabrication, cleaning, flushing and testing to maximum extent possible is recommended and preferable.

3.4 Tank disinfecting. After all other work involving the potable water system and tank closing have been completed, the Contractor shall disinfect and treat the affected potable water tank(s) and associated disturbed piping and components, as necessary, to meet or exceed the requirements of AWWA C652. After tank disinfecting; remove and dispose of all treated water in accordance with all Federal, state and local regulations. Ensure that no one enters the tanks once disinfection is completed.

3.5 Hydrostatic test. After all authorized repairs, the Contractor shall hydrostatically test all new and disturbed piping and components of the potable water system in accordance with SFLC Std Spec 0740, Appendix C, “Hydrostatic Test”. Ensure zero leakage from or permanent deformation of pressure-containing parts by repairing all leaks, deformations, and discrepancies. Submit a CFR.

USCGC ALDER (WLB-225B) DOCKSIDE AVAILABILITY FY2020

3.6 Piping insulation installation. The Contractor shall install new insulation materials over the exposed pipe surfaces at thicknesses appropriate to the application and temperature ranges specified in ASTM F683 Tables and in accordance with details in NAVSEA Drawing 804-5959214:

3.6.1 Coat the newly installed insulation system in accordance with SFLC Std Spec 6310, Appendix B (Cutter and Boat Interior Painting Systems).

3.7 Touch-up preservation, general. The Contractor shall prepare and coat all new and disturbed exterior and interior surfaces, as applicable, to match existing adjacent surfaces in accordance with SFLC Std Spec 6310, paragraph 3.1.13 (Touch-ups and minor coating repairs.)

4. NOTES

This section is not applicable to this work item.

WORK ITEM 14: Steering Hydraulic Pipe Hanger Repair

1. SCOPE

1.1 Intent. This work item describes the requirements for the Contractor to repair the repair the Steering Hydraulic Piping support brackets in the Steering Gear Room (1-102-0-E).

1.2 Government-furnished property.

None.

2. REFERENCES

COAST GUARD DRAWINGS

Coast Guard Drawing 225B-WLB 601-1, Rev J, General Arrangements, Inboard and Outboard Profiles

Coast Guard Drawing 225B-WLB 561-4, Rev E, Steering Components Arrangement and Detail

Coast Guard Drawing 225B-WLB 505-1, Rev D, General Requirements For Piping Systems

COAST GUARD PUBLICATIONS

Surface Forces Logistics Center Standard Specification 0000 (SFLC Std Spec 0000), 2018, General Requirements

Surface Forces Logistics Center Standard Specification 0740 (SFLC Std Spec 0740), 2018, Welding and Allied Processes

Surface Forces Logistics Center Standard Specification 5000 (SFLC Std Spec 5000) 2018, Auxiliary Machine Systems

Surface Forces Logistics Center Standard Specification 6310 (SFLC Std Spec 6310), 2018, Requirements for Preservation of Ship Structures

OTHER REFERENCES

The Society for Protective Coatings (SSPC) Surface Preparation Specification No.11 (SSPC-SP 11), 2004, Power Tool Cleaning to Bare Metal

3. REQUIREMENTS

3.1 General.

USCGC ALDER (WLB-225B) DOCKSIDE AVAILABILITY FY2020

3.1.1 CIR. The Contractor shall submit a CIR for the inspections listed in the following paragraph(s):

None.

3.1.2 Tech Rep. Not applicable.

3.1.3 Protective measures. The Contractor shall furnish and install all protective coverings to seal off and protect all non-affected vessel's components, equipment, and spaces near the work area against contamination during the performance of work. Upon completion of work, the Contractor shall remove all installed protective measures, inspect for the presence of contamination, and return all contaminated equipment, components, and spaces to original condition of cleanliness.

3.1.4 Interferences. The Contractor shall handle all interferences in accordance with SFLC Std Spec 0000, paragraph 3.3.5 (Interferences). Known interferences include, but are not limited to the following:

- Steering Hydraulic piping.
- Electrical equipment and wiring.
- Insulation.

3.2 Work Location. The concerned work area is the Steering Gear Room (1-102-0-E), steering hydraulic piping and piping support elements between frame 107 and 108. See **PHOTOS 1, 2, and 3** below and the Coast Guard Drawings above for guidance and details.

NOTE:

Open, ventilate, and clean all spaces and components necessary to accomplish this work item as required to certify them as "SAFE FOR PERSONNEL" and/or "SAFE FOR HOT WORK."

3.3 Inspection and repair particulars. The Contractor shall accomplish the following tasks using the Coast Guard drawings referenced above and SFLC Std Specs 0000 and 0740 as guidance:

3.3.1 Visual inspect the steering hydraulic pipe hangers and other pipe support elements in the work location described in Para 3.2 for cracks or damage.

3.3.2 The Contractor shall cite the cracked or damaged pipe hangers or brackets. Submit a CFR.

3.3.3 Upon verification from the Coast Guard Inspector repair and renew cracked pipe hangers in accordance with SFLC Std Spec 0740 and Coast Guard Drawings 225B-WLB 505-1.

3.4 The Contractor shall perform NDI of the repair welds in accordance with SFLC Std Spec 0740, Appendix C. Submit a CFR.

3.5 Touch-up preservation. The Contractor shall prepare and coat all new and disturbed exterior and interior surfaces to match existing adjacent surfaces, in accordance with SFLC Std Spec 6310, Appendix A (Cutter and Boat Exterior Painting Systems) and Appendix B (Cutter and Boat Interior Painting Systems), respectively, and as applicable.

3.6 Inspect and test. The Contractor shall inspect and test the Hydraulic Steering system in accordance with SFLC Std Spec 5000 and Coast Guard Drawing 225B-WLB 561-4, if applicable.

4. NOTES

This section is not applicable to this work item. PHOTOS below.

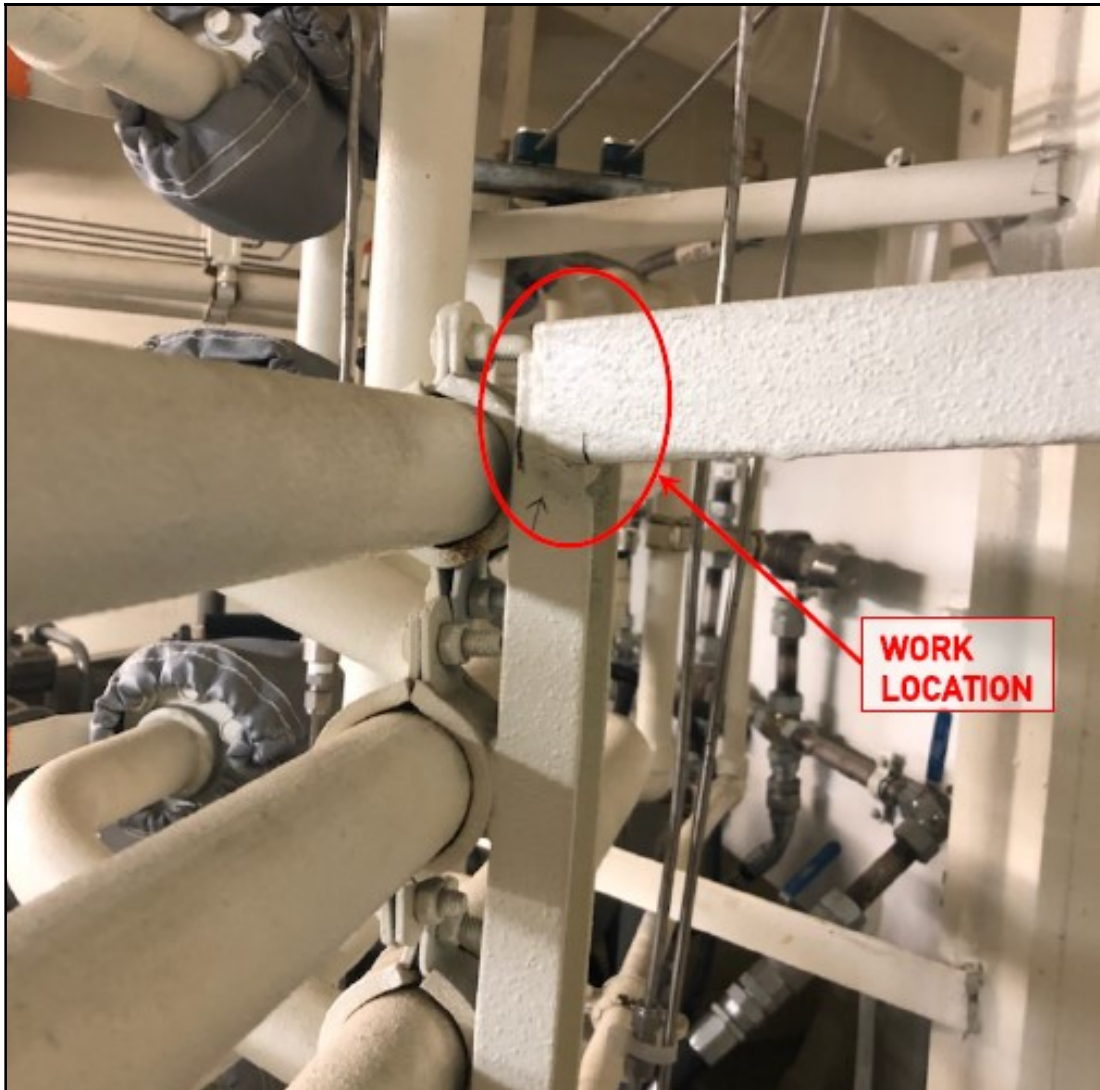

PHOTO 1 WORK LOCATION - STEERING GEAR ROOM – CRACKED PIPE HANGER BRACKET



PHOTO 2 CRACKED STEERING HYD PIPE HANGER BRACKET DETAIL



USCGC ALDER (WLB-225B) DOCKSIDE AVAILABILITY FY2020

PHOTO 3 CRACKED STEERING HYD PIPE HANGER BRACKET DETAIL (BACK-SIDE)

WORK ITEM 15: Fire Pump Discharge Piping, Renew

1. SCOPE

1.1 Intent. This work item describes the requirements for the Contractor to renew the fire main discharge piping section on the #1 fire pump. 1.2 Government-furnished property.

None.

2. REFERENCES

COAST GUARD DRAWINGS

Coast Guard Drawing 225B-WLB 521-1, Rev -, Fire-main System Diagram

Coast Guard Drawing 225B-WLB 521-6, Rev -, Fire-main System A/D, FR 66 Aft, Block 940,950

COAST GUARD PUBLICATIONS

Surface Forces Logistics Center Standard Specification 0000 (SFLC Std Spec 0000), 2018, General Requirements

Surface Forces Logistics Center Standard Specification 0740 (SFLC Std Spec 0740), 2018, Welding and Allied Processes

Surface Forces Logistics Center Standard Specification 6310 (SFLC Std Spec 6310), 2018, Requirements for Preservation of Ship Structures

OTHER REFERENCES

Manufacturers Standardization Society of the Valve and Fittings Industry (MSS), SP-58, 2009, Pipe Hangers and Supports – Materials, Design, Manufacture, Selection, Application and Installation

3. REQUIREMENTS

3.1 General.

3.1.1 CIR.

None.

3.1.2 Tech Rep.

Not applicable.

3.1.3 Protective measures. The Contractor shall furnish and install all protective coverings to seal off and protect all non-affected vessel's components, equipment, and spaces near the work area against contamination during the performance of work. Upon completion of work, the Contractor shall remove all installed protective measures, inspect for the presence of contamination, and return all contaminated equipment, components, and spaces to original condition of cleanliness.

3.1.4 Interferences. The Contractor shall handle all interferences in accordance with SFLC Std Spec 0000, paragraph 3.3.5 (Interferences). Known interferences include, but are not limited to the following:

- Piping.
- Wire runs and Paneling.
- Piping /wiring of other systems in vicinity.

WARNING

Do not drain any fluids including fresh water, into any space, bilge, or exterior location.

3.2 Fire Main pipe renewal. The work location is in the MMR (4-66-0-E). The Contractor shall do the following:

3.2.1 Remove and renew a section of discharge piping on #1 fire pump due to the crack weld at the jumper hose connection in according with Coast Guard Drawing 225B-WLB 521-1 and 6, and SFLC Std Spec 0740.

3.2.2 Renew 6 in butterfly valve on the upper section, and two 2 in jumper hose gate valves in this section.

3.3 Pipe support installation. The Contractor shall furnish, fit, and install new pipe support / hangers in accordance with MSS SP-58 and Coast Guard Drawing 225B-WLB 521-1 and 6.

3.4 Hydrostatic test. After all authorized repairs, the Contractor shall hydrostatically test all new and disturbed piping and components of the disturbed system in accordance with SFLC Std Spec 0740, Appendix C, "Hydrostatic Test". Be aware that no leakage or permanent deformation of pressure-containing parts is permissible. Repair all leaks and discrepancies found. Submit a CFR.

3.5 Operational test. In the presence of the Coast Guard Inspector, conduct an operational test of the renewed and affected piping system at normal operating system pressure/vacuum to verify tightness. Repair all leaks on disturbed connections.

3.6 Boundary test. The Contractor shall verify the integrity of all boundaries affected by this work item using one of the methods described in SFLC Std Spec 0740, Appendix C. Submit a CFR.

3.7 Touch-up preservation, general. The Contractor shall prepare and coat all new and disturbed exterior and interior surfaces, as applicable, to match existing adjacent surfaces in accordance with SFLC Std Spec 6310, paragraph 3.1.13 (Touch-ups and minor coating repairs.)

4. NOTES

This section is not applicable to this work item.

WORK ITEM 16: LO Tank Vent Repair

1. SCOPE

1.1 Intent. This work item describes the requirements for the Contractor to repair the vent pipe for Lube Oil storage tank 2-83-1-F.

1.2 Government-furnished property.

None.

2. REFERENCES

COAST GUARD DRAWINGS

Coast Guard Drawing 225B-WLB 601-1, Rev J, General Arrangements, Inboard and Outboard Profiles

Coast Guard Drawing 225B-WLB 506-1, Rev G, Overflows, Air Escapes And Sounding Tubes Diagram

Coast Guard Drawing 225B-WLB 506-9, Rev -, MMA Overflows, Air Escapes & Sndg Tubes Diag

Coast Guard Drawing 225B-WLB 505-1, Rev D, General Requirements For Piping Systems

COAST GUARD PUBLICATIONS

Surface Forces Logistics Center Standard Specification 0000 (SFLC Std Spec 0000), 2018, General Requirements

Surface Forces Logistics Center Standard Specification 0740 (SFLC Std Spec 0740), 2018, Welding and Allied Processes

Surface Forces Logistics Center Standard Specification 5000 (SFLC Std Spec 5000) 2018, Auxiliary Machine Systems

Surface Forces Logistics Center Standard Specification 6310 (SFLC Std Spec 6310), 2018, Requirements for Preservation of Ship Structures

Other ReferencesThe Society for Protective Coatings (SSPC) Surface Preparation Specification No.11 (SSPC-SP 11), 2004, Power Tool Cleaning to Bare Metal

3. REQUIREMENTS

3.1 General.

USCGC ALDER (WLB-225B) DOCKSIDE AVAILABILITY FY2020

3.1.1 CIR. The Contractor shall submit a CIR for the inspections listed in the following paragraph(s):

None.

3.1.2 Tech Rep. Not applicable.

3.1.3 Protective measures. The Contractor shall furnish and install all protective coverings to seal off and protect all non-affected vessel's components, equipment, and spaces near the work area against contamination during the performance of work. Upon completion of work, the Contractor shall remove all installed protective measures, inspect for the presence of contamination, and return all contaminated equipment, components, and spaces to original condition of cleanliness.

3.1.4 Interferences. The Contractor shall handle all interferences in accordance with SFLC Std Spec 0000, paragraph 3.3.5 (Interferences). Known interferences include, but are not limited to the following:

- Reduction gear LO Storage tank 2-83-1-F and piping.
- Lube Oil

NOTE:

Due to need for removal of lube oil this WI should be performed in conjunction with WI#4 Tanks (Lube Oil), Clean and Inspect

3.2 Work Location. The concerned work area is the AMR (4-82-0-E) Upper Level, starboard, the reduction gear lube oil storage tank, vent and piping. See the Coast Guard Drawings above, for guidance and details.

NOTE:

Open, ventilate, and clean all spaces and components necessary to accomplish this work item as required to certify them as "SAFE FOR PERSONNEL" and/or "SAFE FOR HOT WORK."

3.3 Inspection and repair particulars. The Contractor shall accomplish the following tasks using the Coast Guard drawings referenced above and SFLC Std Specs 0000 and 0740 as guidance:

3.3.1 Visual inspect the tank vent for cracks or damage in the work location described in Para 3.2.

3.3.2 The Contractor shall determine the extent of the crack in the vent pipe. Submit a CFR.

3.3.3 Upon verification from the Coast Guard Inspector crop and renew cracked portion of the vent pipe in accordance with SFLC Std Spec 0740, use Coast Guard Drawings 225B-WLB 506-1 and 225B-WLB 506-9 as guidance.

3.4 The Contractor shall perform NDI of the repair welds in accordance with SFLC Std Spec 0740, Appendix C. Submit a CFR.

3.5 Touch-up preservation. The Contractor shall prepare and coat all new and disturbed exterior and interior surfaces to match existing adjacent surfaces, in accordance with SFLC Std Spec 6310, Appendix A (Cutter and Boat Exterior Painting Systems) and Appendix B (Cutter and Boat Interior Painting Systems), respectively, and as applicable.

USCGC ALDER (WLB-225B) DOCKSIDE AVAILABILITY FY2020

3.6 Clean and test. The Contractor shall clean and test the disturbed system in accordance with Coast Guard Drawings 225B-WLB 506-1, see General Notes.

4. NOTES

This section is not applicable to this work item.

WORK ITEM 17: Chain Washdown Coupling, Install

1. SCOPE

1.1 Intent. This work item describes the requirements for the Contractor to provide and install chain washdown couplings to the port and starboard hawse pipes.

1.2 Government-furnished property.

None.

2. REFERENCES

COAST GUARD DRAWINGS

Coast Guard Drawing 225B WLB 581-001, Rev D, Anchor Handling System Arrangement

COAST GUARD PUBLICATIONS

Surface Forces Logistics Center Standard Specification 0000 (SFLC Std Spec 0000), 2018, General Requirements

Surface Forces Logistics Center Standard Specification 0740 (SFLC Std Spec 0740), 2018, Welding and Allied Processes

Surface Forces Logistics Center Standard Specification 6310 (SFLC Std Spec 6310), 2018, Requirements for Preservation of Ship Structures

OTHER REFERENCES

None

3. REQUIREMENTS

3.1 General.

3.1.1 CIR.

None.

3.1.2 Tech Rep. Not applicable.

3.1.3 Protective measures. The Contractor shall furnish and install all protective coverings to seal off and protect all non-affected vessel's components, equipment, and spaces near the work area against

USCGC ALDER (WLB-225B) DOCKSIDE AVAILABILITY FY2020

contamination during the performance of work. Upon completion of work, the Contractor shall remove all installed protective measures, inspect for the presence of contamination, and return all contaminated equipment, components, and spaces to original condition of cleanliness.

3.1.4 Interferences. The Contractor shall handle all interferences in accordance with SFLC Std Spec 0000, paragraph 3.3.5 (Interferences).

3.2 Washdown coupling installation. The Contractor shall modify port and starboard hawse pipes and provide and install washdown couplings in accordance with Coast Guard Drawing 225B WLB 581-001 Plan 4-A and Section 6-A. All welding shall be in accordance with SFLC Std Spec 0740.

3.3 Touch-up preservation. The Contractor shall prepare and coat all new and disturbed surfaces to match existing adjacent surfaces in accordance with SFLC Std Spec 6310, paragraph 3.1.13 (Touch-ups and minor coating repairs.)

4. NOTES

This section is not applicable to this work item.

WORK ITEM 18: Main Diesel Engine, Vulkan Coupling Renew

1. SCOPE

1.1 Intent. This work item describes the requirements for the Contractor to renew the Vulkan Coupling between the Port Main Diesel Engine (MDE) and its respective Main Reduction Gear (MRG).

1.2 Government-furnished property.

MTI	ITEM DESCRIPTION	NSN/PN	QTY	ESTIMATED COST (\$/UNIT)
N	***Vulkan RATO Flexible Coupling Element	PN: 1G33214105 NSN: 3010-01-494-1016	1.ea.	60,537.00

***Government-furnished property, which is to be supplied by the vessel.

2. APPLICABLE DOCUMENTS

COAST GUARD DRAWINGS

Coast Guard Drawing 225B-WLB 233-1, Rev D, Propulsion Train Installation Drawing

COAST GUARD PUBLICATIONS

Coast Guard Technical Publication (TP) 3518B, 07-MAY-01, Main Diesel Engine (MDE) - Model 3608/1

Coast Guard Technical Publication (TP) 3523B, May 2001; Coupling, Torsional (Flexible), Manufacturer: American Vulkan, Model NO. RATO-S 3321-2100/1070 (Rev B)

Surface Forces Logistics Center Standard Specification 0000 (SFLC Std Spec 0000), 2018, General Requirements

OTHER REFERENCES

The Society for Protective Coatings (SSPC) Surface Preparation Specification No.1 (SSPC-SP 1), 2004, Solvent Cleaning

CAT Alignment Application and Installation Guide

3. REQUIREMENTS

3.1 General.

3.1.1 CIR.

None.

3.1.2 Tech Rep. The Contractor shall provide the services of qualified Tech Rep, who is familiar with – Large Diesel Engine Alignment to accomplish the following tasks – on site:

- Measure states of alignment.
- Furnish and use laser alignment tools and fixtures in measuring alignment.
- Determine engine movements to obtain satisfactory alignment
- Determine shim thicknesses as required to even load engine mounts.

3.1.2.1 The Contractor shall submit the name of the Tech Rep to the COR at the Arrival Conference.

3.1.2.2 The Contractor shall be required to have this Technical Representative present (mandatory), on site, while the following engine work is being performed:

- a. When obtaining all alignment readings/measurements, and all engine movement events (jacking screws being turned)

NOTE

The Technical Representative may be present at other times in addition to the mandatory times listed above. The above represents the minimum required Technical Representative usage.

3.1.3 Protective measures. The Contractor shall furnish and install suitable covering to seal off and protect all non-affected surfaces/equipment and spaces near the work area against contamination during the performance of work. Upon completion of work, remove protective material and inspect for the presence of contamination. Clean all equipment and spaces, contaminated due to improper protection, to original condition of cleanliness.

3.1.4 Interferences. The Contractor shall handle all interferences in accordance with SFLC Std Spec 0000, paragraph 3.3.5 (Interferences).

3.2 Renew the Vulkan Coupling. The Contractor shall renew Vulkan coupling as follows;

3.2.1 Disconnect and remove Vulkan coupling.

3.2.2 Measure with laser alignment tools the existing state of alignment of MDE to MRG (with Vulkan coupling unbolted or removed).

3.2.3 Submit CFR with the following:

- Any components needing renewal
- Post installation alignment readings

USCGC ALDER (WLB-225B) DOCKSIDE AVAILABILITY FY2020

3.2.4 The Vulkan coupling details are shown in Figure at end of this specification. Figure was obtained from CG Tech Pub 3523B, which shall be consulted along with OEM for additional information as required.

3.3 Engine Alignment Check.

3.3.1 The following work shall be completed after the cutter is afloat with normal operating levels of fuel, water and ballast.

3.3.2 The following work shall accomplished under supervision of Alignment Tech Rep.

3.3.3 At this point the engine pre-heaters should be turned on and the engine brought up to temperature, a process that will take approximately ½ hour. This will allow all thermal expansion of the engine to take place. With the engine up to temperature, the alignment can be rechecked.

3.3.4 Measure the engine alignment again in the presence of the COR. The following tolerances apply for radial (rim) and for angular (face) displacement: +/- 0.020". Total Indicator readings (TIR) would be twice the value. Note the engine is intentionally offset 0.032" to Port per drawing for engine torque effects. In addition additional offsets have been factored in to allow for outboard expansion of Reduction Gear's input flange due to increased temperatures at normal operating conditions (HOT) vs. ambient conditions found during alignment (COLD). See following Table to re-enforce alignment criteria.

TABLE 2 – PORT MDE ALIGNMENT CRITERIA

ACCEPTABLE RANGE OF RADIAL ALIGNMENT (RIM DISPLACEMENT)		ACCEPTABLE ANGULAR ALIGNMENT (FACE DISPLACEMENT)	
Vertical displacement	Horiz displacement (includes Red Gear expansion outboard due to 60F degree temp delta HOT-COLD)	Vertical displacement	Horiz displacement
0.020" engine high to 0.020" engine low	0.070" engine to port to 0.030" engine to port	0.020" or less	0.020" or less

TABLE 3 – STARBOARD MDE ALIGNMENT CRITERIA

ACCEPTABLE RANGE OF RADIAL ALIGNMENT (RIM DISPLACEMENT)		ACCEPTABLE ANGULAR ALIGNMENT (FACE DISPLACEMENT)	
Vertical displacement	Horiz displacement (includes Red Gear expansion outboard due to 60F degree temp delta HOT-COLD)	Vertical displacement	Horiz displacement
0.020" engine high to 0.020" engine low	0.034" engine to port to 0.006" engine to STBD	0.020" or less	0.020" or less

3.3.6 Ensure jacking screws are all removed or withdrawn, then record the engine alignment readings.

3.3.7 Measure and record the height of each vibration mount following instructions of Christie & Grey Data Sheet DS 094 (attached). Ensure they are within compliance of Christie & Grey Data Sheet DS 096 (attached). Provide copy of post transfer mount heights to Christie & Grey. The heights are expected to be roughly equal at each isolator ensuring they are all carrying equal load. Flange face alignments may be

USCGC ALDER (WLB-225B) DOCKSIDE AVAILABILITY FY2020

excellent at same time an interior mount was completely unloaded. Record the data in a copy of the attached data sheet (found as enclosure at end of specification) for each MDE. Measurements will be witnessed by the COR.

3.4 Submit final report to COR with alignment results and any recommendations for realignment. Realignment normally requires adding shims to account for mount sagging. Should realignment be agreed to it would be subject to a contract change.

3.5 Reassemble the engine components e.g. coupling, coupling guards. Ensure mounts are final torqued. Ensure jacking screws are all removed or withdrawn.

4. NOTES

This section is not applicable to this work item.

WORK ITEM 19: Ship Service Diesel Generator, Clean & Inspect

1. SCOPE

1.1 Intent. This work item describes the requirements for the Contractor to inspect, recondition, and test in place each Ship Service Diesel Generator (SSDG).

1.2 Government-furnished property.

None.

2. REFERENCES

COAST GUARD DRAWINGS

Coast Guard Drawing 225B-WLB 201-2, Rev C, Access Removal Routes

COAST GUARD PUBLICATIONS

Coast Guard Technical Publication (TP) 3537B, Manufacturer's Instruction Book – SWBS Group(s) 310

Surface Forces Logistics Center Standard Specification (SFLC Std Spec) 0450, 2018, Electrical Power for Contractor's Tools & Equipment

Surface Forces Logistics Center Standard Specification (SFLC Std Spec) 3100, 2018, Inspect, Test and Recondition AC Synchronous Machines In-Place

OTHER REFERENCES

American National Standards Institute (ANSI/EASA) AR100, 2015, Recommended Practice for the Repair of Rotating Electrical Apparatus

3. REQUIREMENTS

3.1 General. The Contractor shall inspect, recondition, and test in place the Ship Service Diesel Generators (SSDG) in accordance with SFLC Std Spec 3100, using ANSI/EASA AR100-2015 instead of AR100-2010 as referenced. Generator data is shown in Table 1 below.

TABLE 1 – GENERATOR DATA

QUANTITY	CHARACTERISTICS	MANUFACTURER	LOCATION
2	450 kW, 450 VAC, 60 Hz, 3 phase, 1200 RPM, 0.8 PF	Caterpillar	Engine Room

3.1.1 CIR. The Contractor shall submit a CIR for the inspections listed in the following paragraph(s) and their sub-paragraph(s) of SFLC Std Spec 3100:

- 3.2.2 Air gap clearances.
- 3.2.3 Disassembly and inspections.

3.1.1.1 The Contractor shall note in the CIR if any test or inspection results are unsatisfactory and if so, what is the recommendation from the Technical Representative (Tech Rep) to resolve the concerns.

3.1.2 Tech Rep. The Contractor shall provide the services of a Qualified Technical Representative who is familiar with AC synchronous machine repair to accomplish the following on site:

- Advise on manufacturer's proprietary system information.
- Assist with the removal, installation, repair, and overhaul in accordance with ANSI/EASA AR100.
- Ensure compliance with manufacturer's procedures and ANSI/EASA AR100 standards during system disassembly, inspection, and reassembly as applicable.
- Witness the performance of all tests, inspections, and cleaning operations performed under this specification.

3.1.2.1 Ensure the Tech Rep has experience with the system/equipment stated above and demonstrated on their résumé and is employed by a shop that is a member of the Electrical Apparatus Service Association (EASA).

3.1.2.2 Submit the name and résumé of the Tech Rep to the COR at the Arrival Conference.

3.1.3 Protective measures. The Contractor shall furnish and install all protective coverings to seal off and protect all non-affected vessel's components, equipment, and spaces in the vicinity of the work area against contamination during the performance of work. Upon completion of work, remove all installed protective measures, inspect for the presence of contamination, and return all contaminated equipment, components, and spaces to original condition of cleanliness.

3.1.4 Interferences. The Contractor shall handle all interferences in accordance with SFLC Std Spec 0000, paragraph 3.3.5 (Interferences).

3.2 Requirements. The Contractor shall accomplish all work detailed in SFLC Std Spec 3100, with the exception of the following (unless a Change Request has been authorized and released by the KO):

3.2.1 Bearing wear. The Contractor shall not measure and record bearing wear in accordance with SFLC Std Spec 3100, Section 3.2.3.6, Bearing wear.

3.2.2 Collector rings. The Contractor shall not measure and record collector ring wear and concentricity in accordance with SFLC Std Spec 3100, Section 3.2.3.7, Collector ring wear and concentricity.

USCGC ALDER (WLB-225B) DOCKSIDE AVAILABILITY FY2020

3.2.3 Installed prime mover. The Contractor shall not use the installed prime mover (e.g., engine or barring gear) to spin the rotor while circulating current through the field windings during drying operations.

3.3 Insulation treatment. The Contractor shall touch up thin and bare spots on the cleaned windings with an air drying varnish in accordance with SFLC Std Spec 3100, 3.3.2, Insulation treatment.

3.4 Utility services. The Contractor’s use of Coast Guard utility services, both afloat and ashore, is restricted as follows for performance of this work item:

3.4.1 Electrical power. The Contractor’s use of electrical power for temporary tools and equipment used to accomplish this work item shall comply with SFLC Std Spec 0450. When no other power source options are practicable, such loads may be energized from a temporary generator located afloat or ashore in accordance with Appendix E of SFLC Std Spec 0450.

3.4.1.1 Dockside equipment. Power solely for dockside tools and equipment may be taken from the dockside electrical power distribution system in accordance with Appendix A (preferred) of SFLC Std Spec 0450 or from the shipboard electrical power distribution system in accordance with Appendix D of SFLC Std Spec 0450.

3.4.2 Potable water. The Contractor’s use of hot and cold potable water may be obtained from shipboard systems.

3.4.3 Compressed air. The Contractor’s use of compressed air for tools and generator hand cleaning may be taken from the ship service air system. Air that is to be blown into a generator shall be filtered for particulate, water, and oil prior to discharge.

3.5 External heating. The Contractor shall apply external heat following cleaning to dry out the windings. The heater power rating will vary with the amount of equipment to be dried, degree of enclosure, and amount of ventilation. The estimate in Table 2 below assumes that no heat is lost by radiation or by forced or natural convection; consequently, the input power rating should be increased by a few kilowatts to compensate for heat losses.

3.5.1 The Contractor shall limit heat input so that winding temperatures do not increase more than 20°F per hour.

3.5.2 The Contractor shall not exceed a winding temperature of 167°F.

TABLE 2 – EXTERNAL HEATING DATA

MACHINE WT (LBS)	HEATER POWER		HEATUP RATE (°F/H)	TEMPERATURE RISE (°F)	DURATION (H)
	(KW)	(BTU/H)			
5,651	3.9	13,306	20	107	5.4

4. NOTES

4.1 Conditional performance. This work item is performed only when warranted by the condition of the generator windings. The mere presence of dust is not sufficient justification to perform this work item.

4.1.1 Note that there is some risk that solutions used during the cleaning process may penetrate through microscopic cracks in the varnish, carrying contaminants deeper into the windings through capillary action. Once so embedded, such contamination cannot be removed and insulation resistance could actually be degraded such that a costly and time consuming rewind would be necessary.

4.1.2 Cleaning is normally only warranted when the windings have been wetted by sea water or insulation resistance trends suggest that the machine will fall below the minimum acceptable insulation resistance for operation before the next depot level availability.

4.2 Shop cleaning. This generator is (rotor only) removable from the vessel without making a hull cut. See CG Drawing 225B-WLB 201-2 for rigging path to weather including any bolted (BERP) or welded (WERP) equipment removal plates that must be removed. For machines that can be removed from the vessel through existing accesses or openings created by other work items, it is generally quicker and more cost effective to offload the affected generator from the vessel and perform the work ashore in a generator repair shop. Such tasking should be performed under “Ship Service Diesel Generator, Overhaul” and not this work item.

WORK ITEM 20: Component, Work Description

1. SCOPE

1.1 Intent. This work item describes the requirements for the Contractor to inspect, maintain, and test power circuit breakers located on the Ship Service and Emergency Switchboards that were designed and tested to UL 1066 standards.

1.2 Government-furnished property.

None.

2. REFERENCES

COAST GUARD DRAWINGS

Coast Guard Drawing 225B-WLB 320-1, Rev AC, Electrical One Line Diagram

COAST GUARD PUBLICATIONS

Surface Forces Logistics Center Standard Specification (SFLC Std Spec) 0000, 2018, General Requirements

Surface Forces Logistics Center Standard Specification (SFLC Std Spec) 3042, 2018, Shipboard Electrical Cable Removal, Relocation, Splice, Repair, and Installation

Coast Guard Technical Publication (TP) 3536, Jul 2003, Switchboard, Main, Emergency, and Thruster

OTHER REFERENCES

American National Standards Institute/National Electrical Manufacturers Association (ANSI/NEMA) AB 4, Mar 2011, Guidelines for Inspection and Preventive Maintenance of Molded Case Circuit Breakers Used in Commercial and Industrial Applications

Underwriters Laboratories Inc. (UL) 1066, Low-Voltage AC and DC Power Circuit Breakers Used in Enclosures, Apr 2012

3. REQUIREMENTS

3.1 General.

3.1.1 CIR. The Contractor shall submit a CIR for the inspections and test listed in the following paragraph(s):

USCGC ALDER (WLB-225B) DOCKSIDE AVAILABILITY FY2020

- 3.2 (Operational assessment).
- 3.4.2 (Inspection).
- 3.4.3 (Testing).

3.1.2 Tech Rep. The Contractor shall provide the services of a technician employed by the original equipment manufacturer or an InterNational Electrical Testing Association (NETA) accredited Tech Rep to accomplish the following on site:

- Provide manufacturer's proprietary system/ equipment information, software, and tools.
 - Assist with and ensure compliance with manufacturer's procedures and standards during disassembly, inspection, repair, modification, calibration, and reassembly of the equipment/system.
 - Ensure test equipment is calibrated

3.1.2.1 Ensure the Tech Rep is a NETA certified technician for the system/equipment stated above and demonstrated on their résumé.

3.1.3 Protective measures. The Contractor shall furnish and install all protective coverings to seal off and protect all non-affected vessel's components, equipment, and spaces near the work area against contamination during the performance of work. Upon completion of work, the Contractor shall remove all installed protective measures, inspect for the presence of contamination, and return all contaminated equipment, components, and spaces to original condition of cleanliness.

3.1.4 Interferences. The Contractor shall handle all interferences in accordance with SFLC Std Spec 0000, paragraph 3.3.5 (Interferences).

3.1.5 The Contractor shall notify the Coast Guard Inspector 48 hours prior to starting work on this item.

3.1.6 Outages. The Contractor shall coordinate the disconnection and removal of the circuit breakers listed in the table below with the Coast Guard Inspector to ensure orderly shutdown of equipment. Providing temporary circuit breakers or temporarily relocating circuit breakers from non-essential circuits to essential circuits (same frame size and trip settings) are acceptable strategies to minimize outage durations. When power interruption is expected to exceed 15 minutes, secure uninterruptable power supplies and supported loads.

3.1.7 Essential circuits. The Contractor shall minimize the interruption of power to the following circuits unless they are actively being serviced by other work items:

3.1.7.1 Ship service lighting (unless temporary lighting is installed).

3.1.7.2 Fire (circuits F and SM), flooding (circuit FD), and general (circuit G) alarms.

3.1.7.3 Main announcing (circuit 1MC) and dial telephone (circuit J) systems.

3.1.7.4 Galley, scullery, potable water heater, HVAC, and sewage systems (unless cutter crew is not living on board).

3.1.7.5 Electric fire pump (unless temporary firefighting water supply is connected).

USCGC ALDER (WLB-225B) DOCKSIDE AVAILABILITY FY2020

3.2 Operational assessment. The Contractor shall perform an operational assessment of each circuit breaker listed in the table below prior to removal from the switchboard. Submit an operational assessment report as a CIR.

3.2.1 General.

3.2.1.1 Ship's Force shall operate all equipment, as well as remove and reinstall control power fuses.

3.2.1.2 For cutters with stationary mounted circuit breakers or draw-out type with no TEST position, Ship's Force shall run generators or operate shore power, as necessary, to establish safe plant conditions for the operational assessment and provide circuit breaker control power. Ensure that water cooled prime movers are furnished with adequate normal or temporary raw water supplies and that required auxiliaries such as batteries, exhaust, ventilation, start air, fuel oil, jacket water, and lube oil are available.

3.2.1.3 When practicable, operate draw-out type circuit breakers in the TEST position such that the primary contacts (stabs) are disconnected from the switchboard bus but all secondary (control) contacts are still connected to switchboard circuits. For generator circuit breakers, remove the control power transformer secondary winding fuses. Taking appropriate electrical safety precautions, connect a Contractor-furnished temporary control power supply, fused to an ampacity no greater than the normal control power supply, to the vacated load side fuse clips.

3.2.1.4 For a circuit breaker that is locked out and/or tagged out (caution or danger tag), typically in support of another work item, complete the tasking requiring the isolation or shift the work isolation boundary so that the lock and/or tags may be cleared. When shifting the isolation boundary is the only feasible option, such is typically accomplished by opening a local disconnect switch or temporarily disconnecting the feeder cable in accordance with SFLC Std Spec 3042. Ensure that a new lock and/or tag are installed at the new isolation boundary prior to clearing those from the circuit breaker to be removed.

3.2.2 Initial conditions. The Contractor shall assume the circuit breaker to be operationally assessed is open with the closing spring charged and control power available.

3.2.3 Manual operation. The Contractor shall perform the following for a circuit breaker with mechanical closing and opening controls on the frame:

3.2.3.1 Manually close the circuit breaker. Verify that the mechanical flag for circuit breaker position, if installed, changes state satisfactorily. Confirm that circuit breaker position indicating lights and machinery control system display, if applicable, also toggle. If installed, verify that the spring charging motor recompresses the closing spring and automatically drops out shortly after the spring is fully charged. If no spring charging motor is installed or it fails to operate, manually recompress the closing spring.

3.2.3.2 Manually trip the circuit breaker. Verify that the mechanical flag for circuit breaker position, if installed, changes state satisfactorily. Confirm that circuit breaker position indicating lights and machinery control system display, if applicable, also toggle.

3.2.3.3 If the circuit breaker is equipped with a mechanical or electrical lockout, activate each lockout device one at a time and verify that the circuit breaker cannot be closed manually.

USCGC ALDER (WLB-225B) DOCKSIDE AVAILABILITY FY2020

3.2.3.4 If the circuit breaker is equipped with an undervoltage release coil, secure power to the coil by removing a secondary control power fuse or securing the temporary control power supply. Attempt to manually close the circuit breaker. Observe indicators and flags to ensure that the main contacts do not close (even momentarily). Discharge of the closing spring is acceptable. Reenergize the undervoltage release coil.

3.2.3.5 For circuit breakers without an undervoltage release coil or for those where the closing spring did not discharge while testing the undervoltage release closing interlock, secure control power to the spring charging motor, ensuring that the undervoltage release coil, if installed, remains energized. Some circuit breaker designs have an internal spring charging motor switch for this purpose; otherwise a control power lead to the motor must be temporarily disconnected at the secondary terminal block. Manually close the circuit breaker and then manually open it to discharge the closing spring.

3.2.3.6 Verify that the mechanical flag for closing spring status, if installed, changes state during this step. Manually charge the closing spring, observing the ratchet mechanism and pawls for signs of damage, such as binding or excessive wear.

3.2.3.7 Reenergize any circuit breaker control circuits that were deenergized in paragraph 3.2.3.5 above.

3.2.4 Electrical operation. The Contractor shall perform the following for a circuit breaker with electrical closing and opening controls on the switchboard:

3.2.4.1 Electrically close the circuit breaker. Verify that the mechanical flag for circuit breaker position and closing spring status, if installed, change state satisfactorily. Confirm that circuit breaker position indicating lights and machinery control system display, if applicable, also toggle. If installed, verify that the spring charging motor recompresses the closing spring and automatically drops out shortly after the spring is fully charged. If no spring charging motor is installed or it fails to operate, manually recompress the closing spring.

3.2.4.2 Electrically trip the circuit breaker. Verify that the mechanical flag for circuit breaker position, if installed, changes state satisfactorily and that the shunt trip coil remains deenergized while the control switch is held in the TRIP position. Confirm that circuit breaker position indicating lights and machinery control system display, if applicable, also toggle.

3.2.4.3 If the circuit breaker is equipped with a mechanical or electrical lockout, activate each lockout device one at a time and verify that the circuit breaker cannot be closed electrically.

3.2.4.4 If the circuit breaker is equipped with an undervoltage release coil, secure power to it by temporarily disconnecting the associated lead at the secondary terminal block; ensure that power to the closing coil and position indicating circuit remains available. Attempt to electrically close the circuit breaker and observe indicators and flags to ensure that the main contacts do not close (even momentarily). Discharge of the closing spring is acceptable.

3.2.4.5 Reenergize any circuit breaker control circuits that were deenergized in paragraph 3.2.4.4 above.

3.2.4.6 If the circuit breaker is equipped with an anti-pump mechanism, electrically close the circuit breaker and continue to hold the control switch in the CLOSE position. If practicable, trip the circuit breaker on fault by simulating an overcurrent condition at the trip unit; otherwise defer this test until the circuit breaker arrives at the maintenance facility. Verify that the circuit breaker does not reclose until the control switch is released and another closing operation is attempted. Open the circuit breaker.

USCGC ALDER (WLB-225B) DOCKSIDE AVAILABILITY FY2020

3.2.5 Bell alarm switch. The Contractor shall perform the following for a circuit breaker with a bell alarm switch:

3.2.5.1 Close the circuit breaker using mechanical or electrical control.

3.2.5.2 If practicable, automatically trip the circuit breaker by simulating an overcurrent condition at the trip unit or by momentarily deenergizing control power to activate the undervoltage release; otherwise defer this test until the circuit breaker arrives at the maintenance facility. Verify that the bell alarm switch contacts are in the tripped state.

3.2.5.3 Manually reset the tripped circuit breaker using mechanical or electrical control. Verify that the bell alarm switch contacts are in the normal state.

3.2.6 Draw-out interlock. The Contractor shall perform the following for a circuit breaker with a draw-out interlock:

3.2.6.1 De-energize both sets of primary contacts (stabs) in the switchboard.

3.2.6.2 If the circuit breaker is equipped with an undervoltage release or can only be operated electrically and temporary control power is not already installed:

3.2.6.2.1 Remove the control power transformer secondary winding fuses.

3.2.6.2.2 Taking appropriate electrical safety precautions, connect a Contractor-furnished temporary control power supply, fused to an ampacity no greater than the normal control power supply, to the vacated load side fuse clips.

3.2.6.3 Ensure that the circuit breaker is withdrawn to the TEST position such that the primary contacts (stabs) are disconnected from the switchboard bus but all secondary (control) contacts are still connected to switchboard circuits.

3.2.6.4 Close the circuit breaker using mechanical or electrical control.

3.2.6.5 Attempt to rack in the closed circuit breaker to the CONNECTED position. Verify that such an operation is physically impossible or confirm that the circuit breaker automatically trips before the stabs reach the primary contacts in the switchboard.

3.2.6.6 If not already tripped, open the circuit breaker using mechanical or electrical control and fully insert it to the CONNECTED position.

3.2.6.7 Close the circuit breaker using mechanical or electrical control.

3.2.6.8 Attempt to rack out the closed circuit breaker to the TEST or DISCONNECTED position. Verify that such an operation is physically impossible or confirm that the circuit breaker automatically trips before the stabs separate from the primary contacts in the switchboard.

3.2.6.9 If not already tripped, open the circuit breaker using mechanical or electrical control.

3.2.7 Spring discharge interlock. The Contractor shall perform the following for a circuit breaker with a spring discharge interlock:

USCGC ALDER (WLB-225B) DOCKSIDE AVAILABILITY FY2020

3.2.7.1 If not already compressed, charge the closing spring.

3.2.7.2 Rack out the open circuit breaker to the DISCONNECTED position. Verify that such an operation is physically impossible or confirm that the closing spring automatically discharges between the TEST and DISCONNECTED positions.

3.2.8 Restoration. The Contractor shall, if authorized in writing by the COR, perform the following for any circuit breaker requiring restoration:

3.2.8.1 Ensure that the circuit breaker is open.

3.2.8.2 If not already accomplished, remove the circuit breaker control power transformer secondary winding fuses and disconnect any temporary control power supply.

3.2.8.3 If compressed, discharge the closing spring.

3.3 Removal.

3.3.1 The Contractor shall record location (position or circuit identifier), wiring information, and if adjustable, as found pickup and time delay settings prior to the removal of each circuit breaker listed in the table below. Retain all mounting and connecting hardware for later reuse. Submit a CIR with all recorded data to the Coast Guard Inspector.

3.3.2 The Contractor shall disconnect and remove the circuit breakers listed in the table below.

3.3.3 The Contractor shall inspect the primary and secondary disconnects in the switchboard for wear and erosion. Check the torques of all primary disconnect studs to the bus work or power cable lugs. Inspect for broken control wiring lugs and check the tightness of wiring at the secondary disconnect terminal blocks. Renew any broken lugs and tighten any loose connections to wiring or bus.

3.3.4 The Contractor shall temporarily cover or insulate switchboard openings created by the removal of circuit breakers to prevent personnel contact with energized conductors and to block the entry of debris from other ongoing industrial activities.

3.4 Shop Work.

3.4.1 Cleaning and lubrication. The Contractor shall clean circuit breaker internals with manufacturer's approved solvents and lint free cloths. Do not use high pressure air or wire brushes. Lubricate all components in accordance with manufacturer's instructions.

3.4.2 Inspection. The Contractor shall perform the inspections and take the measurements described below. Report all results, including any adjustments made, on a CIR.

3.4.2.1 Remove and inspect the arc chutes. Note if an arc chute is severely burned, cracked, or excessively eroded.

3.4.2.2 Visually inspect all primary intermediate (if installed), main, and arcing contacts for erosion and evidence of overheating. Inspect associated insulators for cracks and degradation. Determine whether the condition of one or more contacts or insulators meets the criteria for renewal in accordance with manufacturer's guidelines.

USCGC ALDER (WLB-225B) DOCKSIDE AVAILABILITY FY2020

3.4.2.3 Set up the circuit breaker for maintenance or slow closing. Check alignment and measure the contact force, spring tension, air gap, and wipe on each contact in accordance with manufacturer's instructions and make adjustments, as necessary, to set these values within specification.

3.4.2.4 Check contact closure sequencing to ensure that the differences in the making of the arcing contacts on the same pole and between poles is within manufacturer's tolerances. Also verify that the opening sequencing is satisfactory in the same manner.

3.4.2.5 Reinstall the arc chutes and torque all fasteners in accordance with manufacturer's instructions.

3.4.2.6 Inspect the primary and secondary disconnects (stabs) for wear and erosion. For a circuit breaker with finger type primary disconnects, check that the proper force is applied when a dummy bar, representative of the mating stationary disconnect, is inserted.

3.4.2.7 Inspect mechanical linkages, bearings, pawls, gears, cams, rollers, rods, and shafts for excessive wear and damage. Identify incorrectly assembled components. Note all missing and improperly installed fasteners.

3.4.2.8 Inspect electrical switches, solenoids, relays, wiring, and motors for excessive wear and damage. Perform an insulation resistance check of all control wiring using a 500 VDC test voltage. Isolate and identify any wiring or component with insulation resistance of less than 1 M Ω to ground.

3.4.2.9 For a circuit breaker equipped with a spring charging motor, verify that the motor cutoff switch is aligned in accordance with manufacturer's instructions.

3.4.3 Testing. The Contractor shall test each circuit breaker listed in the table below as directed in this section after satisfactory visual inspection and completion of any authorized repair work. Report all results, on a CIR.

3.4.3.1 Perform the following tests of ANSI/NEMA AB 4, Section 6:

- Mechanical operation
- Insulation resistance
- Individual pole resistance (millivolts drop)
- Inverse-time overcurrent trip (not applicable to non-automatic switches)
- Instantaneous overcurrent trip
- Rated hold-in current

3.4.3.2 Short-time overcurrent trip. This test is applicable only if the circuit breaker is equipped with a short-time delay trip. The operation of the short-time delay unit should be within 90% and 125% of the overcurrent setting of the circuit breaker as shown on the manufacturer's time-current curves.

3.4.3.3 Ground fault trip. The circuit breaker should not be equipped with a ground fault trip. If such is installed, submit a CFR noting the discrepancy.

3.4.3.4 Dielectric test. Perform a dielectric test on each 480 or 600 volt rated circuit breaker where the case was opened for repair or the circuit breaker was obtained through non-OEM authorized supply channels. The dielectric test should be conducted at an AC test voltage of 1568 (480 volt rating) or 1760

USCGC ALDER (WLB-225B) DOCKSIDE AVAILABILITY FY2020

volts (600 volt rating) or at 2500 volts DC for 1 minute withstand. Conduct the dielectric test for each of the following conditions:

- Each pole (line to load terminal) with the circuit breaker open
- Each pair of line to line terminals with the circuit breaker closed
- Each line terminal to ground with the circuit breaker open
- Each pole to ground with the circuit breaker closed

3.4.3.5 For each circuit breaker accessory, perform the applicable tests of ANSI/NEMA AB 4, Section 7. Review the Table 1 configuration below for each circuit breaker and submit a CFR for model number discrepancies as well as any missing or extra accessory. When performing ANSI/NEMA AB 4, Section 7.3, use a variable voltage control power source and voltmeter to measure dropout and pickup voltages of the undervoltage release coil. Dropout voltage shall be between 15% and 60% of the coil voltage rating; pickup shall occur between 30% and 85%.

3.4.3.6 Record the following data for each circuit breaker that was tested:

- Circuit breaker model and serial number
- Circuit identifier or position
- Test data and results
- Test technician name and date of test
- Name and address of testing laboratory

3.4.3.7 Update the label on the circuit breaker case, as necessary, so that it accurately describes the circuit breaker configuration and installed accessories. Apply a sticker showing the name of the testing laboratory along with the date of the test.

3.5 Reinstallation.

3.5.1 The Contractor shall vacuum out the circuit breaker enclosure and completely remove any foreign material.

3.5.2 The Contractor shall lubricate primary and secondary disconnects in accordance with manufacturer's instructions.

3.5.3 The Contractor shall reinstall and reconnect each circuit breaker using information retained in paragraph 3.2.1 above.

3.5.4 The Contractor shall perform an energized operational test of all affected circuit breakers in the presence of the Coast Guard Inspector. Verify that all accessory devices are functioning. For circuit breakers supplying three phase motor loads, either directly or indirectly through intermediate panelboards, perform a phase rotation check if any power wiring was disconnected.

3.5.5 The Contractor shall reconnect all cables disconnected per paragraph 3.2.1.4 above per SFLC Std Spec 3042 when isolation is no longer required.

USCGC ALDER (WLB-225B) DOCKSIDE AVAILABILITY FY2020

4. NOTES

4.1 Inspection periodicity. Circuit breakers are normally maintained, tested, and lubricated at 48 month intervals; however, such should also be performed when the following number of open-close cycles with main contact current flow are exceeded since the last inspection:

4.1.1 800 ampere frame and below – 2800 cycles

4.1.2 900-2500 ampere frame – 800 cycles

4.1.3 3000 ampere frame and above – 400 cycles

4.2 High current fault. When a circuit breaker interrupts a high current fault, perform the arc chute and primary contact inspections before returning the device to operation. Also inspect the associated switchboard bus work for deformation and possible derangement.

TABLE 1 – CIRCUIT BREAKER LIST (WLB225B)

Accessories	Draw-Out With Test Position	X	X	X	X	X
	Undervoltage Release	Instant	Instant	Instant	Instant	
	Shunt Trip Coil	X	X	X	X	X
	Lockout Device, Mech Or Elec					
	Closing Coil, Anti-Pump	CC & AP	CC & AP	CC & AP	CC & AP	CC & AP
	Spring Charging Method(S)	Man/Auto	Man/Auto	Man/Auto	Man/Auto	Man/Auto
	Auxiliary Switch	2NO/2NC	2NO/2NC	2NO/2NC	2NO/2NC	2NO/2NC
	Bell Alarm Switch					
Settings	Instantaneous Pickup (A) [×IR]	2610 [5]	1260 [3.0]	4500 [5]	4500 [5]	2880 [4]
	Short Time Delay	0.40 I ² t out	0.40 I ² t out	0.40 I ² t out	0.40 I ² t out	0.30 I ² t out
	Short Time Pickup (A) [×IL]	1566 [3.0]	1260 [3.0]	2700 [3.0]	2700 [3.0]	2160 [3.0]
	Long Time Delay	30	30	30	30	30
	Long Time Pickup IL (A) [×IR]	522 [0.87]	420 [0.70]	900 [0.75]	840 [0.70]	720 [0.6]
Withdrawal Interlock		X	X	X	X	X
Spring Discharge Interlock		X	X	X	X	X
Rating Plug or Sensor IR (A)		600	600	1200	1200	1200
Part Number		Siemens RL-AS8EAFXBA06D-U7 with Static Trip III	Siemens RL-AS8EAFXBA06D-U7 with Static Trip III	Siemens RL-AS1EAHXBA06D-U7 with Static Trip III	Siemens RL-AS1EAHXBA06D-U7 with Static Trip III	Siemens RL-AS1EAHXBA06D
Frame (A)		800	800	1600	1600	1600

USCGC ALDER (WLB-225B) DOCKSIDE AVAILABILITY FY2020

Function & Location	Emergency Diesel Generator (1E Switchboard)	1E-1S Bus Tie (1E Switchboard)	No. 1 Ship Service Diesel Generator (1S Switchboard)	No. 2 Ship Service Diesel Generator (2S Switchboard)	1S-2S Bus Tie (2S Switchboard)
Circuit	1EG-4EP-1E	1S-4P-1E	1SGA-4P-1S	2SGA-4P-2S	1S-4P-2S

Accessories	Draw-Out With Test Position	X	X	X	X	
	Undervoltage Release	Instant	Instant			
	Shunt Trip Coil	X	X	X	X	
	Lockout Device, Mech Or Elec					
	Closing Coil, Anti-Pump	CC & AP	CC & AP	CC & AP	CC & AP	
	Spring Charging Method(S)	Man/Auto	Man/Auto	Man/Auto	Man/Auto	
	Auxiliary Switch	2NO/2NC	2NO/2NC	2NO/2NC	2NO/2NC	
	Bell Alarm Switch					
Settings	Instantaneous Pickup (A) [×IR]	2000 [5]	2000 [5]	1200 [3]	3000 [5]	
	Short Time Delay	0.40 I ² t out	0.40 I ² t out	0.08 I ² t out	0.08 I ² t out	
	Short Time Pickup (A) [×IL]	1200 [3.0]	1200 [3.0]	1600 [4.0]	3600 [6.0]	
	Long Time Delay	30	30	6	6	
	Long Time Pickup IL (A) [×IR]	400 [1.0]	400 [1.0]	400 [0.50]	600 [0.75]	
	Withdrawal Interlock	X	X	X	X	
	Spring Discharge Interlock	X	X	X	X	
	Rating Plug Or Sensor IR (A)	400	400	800	800	
	Part Number	Siemens RL-AS8EAXBA06D-U7 with Static Trip III	Siemens RL-AS8EAXBA06D-U7 with Static Trip III	Siemens RL-AS8EAGXBA06D with Static Trip III	Siemens RL-AS8EAGXBA06D with Static Trip III	
	Frame (A)	800	800	800	800	
	Circuit	4PSA-1S	4PSB-1S	2S-4P-D	2S-4P-E	

USCGC ALDER (WLB-225B) DOCKSIDE AVAILABILITY FY2020

<p>Function & Location</p>	<p>Bus A Shore Power (1S Switchboard)</p>	<p>Bus B Shore Power (1S Switchboard)</p>	<p>Buoy Deck Equipment Hydraulic Power Unit (2S Switchboard)</p>	<p>Cargo Crane Hydraulic Power Unit (2S Switchboard)</p>	
---	---	---	--	--	--

WORK ITEM 21: Molded Case Circuit Breakers, Inspect & Test

1. SCOPE

1.1 Intent. This work item describes the requirements for the Contractor to inspect and test molded case circuit breakers on the Ship Service and Emergency Switchboards that were designed and tested to UL 489 standards.

1.2 Government-furnished property.

None.

2. REFERENCES

COAST GUARD DRAWINGS

Coast Guard Drawing 225B-WLB 320-1, Rev AC, Electrical One Line Diagram

COAST GUARD PUBLICATIONS

Surface Forces Logistics Center Standard Specification (SFLC Std Spec) 0000, 2018, General Requirements

Surface Forces Logistics Center Standard Specification (SFLC Std Spec) 3042, 2018, Shipboard Electrical Cable Removal, Relocation, Splice, Repair, and Installation

Coast Guard Technical Publication (TP) 3536, Jul 2003, Switchboard, Main, Emergency, and Thruster

OTHER REFERENCES

American National Standards Institute/National Electrical Manufacturers Association (ANSI/NEMA) AB 4, Mar 2011, Guidelines for Inspection and Preventive Maintenance of Molded Case Circuit Breakers Used in Commercial and Industrial Applications

American National Standards Institute/Underwriters Laboratories Inc. (ANSI/UL) 489, Molded Case Circuit Breakers, Molded-Case Switches and Circuit-Breaker Enclosures, Jan 2013

3. REQUIREMENTS

3.1 General.

3.1.1 CIR. The Contractor shall submit a CIR for the inspections and test listed in the following paragraph(s):

USCGC ALDER (WLB-225B) DOCKSIDE AVAILABILITY FY2020

- 3.3.1.2 Inspection.
- 3.3.3 Testing.

3.1.2 Tech Rep. Not applicable.

3.1.3 Protective measures. The Contractor shall furnish and install all protective coverings to seal off and protect all non-affected vessel's components, equipment, and spaces near the work area against contamination during the performance of work. Upon completion of work, the Contractor shall remove all installed protective measures, inspect for the presence of contamination, and return all contaminated equipment, components, and spaces to original condition of cleanliness.

3.1.4 Interferences. The Contractor shall handle all interferences in accordance with SFLC Std Spec 0000, paragraph 3.3.5 (Interferences).

3.1.5 The Contractor shall notify the Coast Guard Inspector 48 hours prior to starting work on this item.

3.1.6 Outages. The Contractor shall coordinate the disconnection and removal of the circuit breakers listed in Table 1 below with the Coast Guard Inspector to ensure orderly shutdown of equipment. Providing temporary circuit breakers or temporarily relocating circuit breakers from non-essential circuits to essential circuits (same frame size and trip settings) are acceptable strategies to minimize outage durations. When power interruption is expected to exceed 15 minutes, secure uninterruptable power supplies and supported loads.

3.1.7 Essential circuits. The Contractor shall minimize the interruption of power to the following circuits unless they are actively being serviced by other work items:

3.1.7.1 Ship service lighting (unless temporary lighting is installed).

3.1.7.2 Fire (circuits F and SM), flooding (circuit FD), and general (circuit G) alarms.

3.1.7.3 Main announcing (circuit IMC) and dial telephone (circuit J) systems.

3.1.7.4 Galley, scullery, potable water heater, HVAC, and sewage systems (unless cutter crew is not living on board).

3.1.7.5 Electric fire pump (unless temporary firefighting water supply is connected).

3.2 Removal.

3.2.1 The Contractor shall, if another work item requires the lock and/or tags be cleared, either complete the task requiring the isolation or shift the work isolation boundary for a circuit breaker that is locked out and/or tagged out (caution or danger tag). When shifting the isolation boundary is the only feasible option, such is typically accomplished by opening a local disconnect switch or temporarily disconnecting the feeder cable in accordance with SFLC Std Spec 3042. Ensure that a new lock and/or tag are installed at the new isolation boundary prior to clearing those from the circuit breaker to be removed.

3.2.2 The Contractor shall record location (position or circuit identifier), wiring information, and if adjustable, as found pickup and time delay settings prior to the removal of each circuit breaker listed in Table 1 below. Retain all mounting and connecting hardware for later reuse. Submit a CFR with all recorded data to the Coast Guard Inspector.

USCGC ALDER (WLB-225B) DOCKSIDE AVAILABILITY FY2020

3.2.3 The Contractor shall disconnect and remove the circuit breakers (except spares) listed in Table 1 below. Temporarily cover or insulate switchboard or panel board openings created by the removal of circuit breakers to prevent personnel contact with energized conductors and the entry of debris from other ongoing industrial activities.

3.3 Shop Work.

3.3.1 Inspection. The Contractor shall perform the visual external inspections and preventive maintenance tasks of ANSI/NEMA AB 4, Sections 4 and 5, respectively. Note that the exposed face temperature check is performed with the circuit breaker load(s) energized to the maximum current encountered under normal operating condition.

3.3.1.1 Record any deficiencies found, including those corrected on the spot.

3.3.1.2 Submit a CIR with repair or renewal recommendations to the Coast Guard Inspector.

3.3.2 Repairs. The Contractor shall, when authorized by the COR, repair deficient circuit breaker(s) that will not be renewed.

3.3.3 Testing. The Contractor shall test each circuit breaker listed in Table 1 as directed below after satisfactory visual inspection and completion of any authorized repair work. New circuit breakers, manufactured within 4 years of installation and obtained from OEM authorized distribution channels, need only be mechanically cycled five times and not tested further. Upon completion, submit a CIR with findings to the Coast Guard Inspector.

3.3.3.1 Perform the following tests of ANSI/NEMA AB 4, Section 6:

- Mechanical operation
- Insulation resistance
- Individual pole resistance (millivolts drop)
- Inverse-time overcurrent trip (not applicable to devices with instantaneous trip only)
- Instantaneous overcurrent trip
- Rated hold-in current

3.3.3.2 Short-time overcurrent trip. This test is applicable only if the circuit breaker is equipped with a short-time delay trip. This test should be conducted at an ambient air temperature of 25°C. The operation of the short-time delay unit should be within 90% and 125% of the overcurrent setting of the circuit breaker as shown on the manufacturer's time-current curves.

3.3.3.3 Dielectric test. Perform a dielectric test on each 480 or 600 volt rated circuit breaker where the case was opened for repair or the circuit breaker was obtained through non-OEM authorized supply channels. The dielectric test should be conducted at an AC test voltage of 1568 (480 volt rating) or 1760 volts (600 volt rating) or at 2500 volts DC for 1 minute withstand. Conduct the dielectric test for each of the following conditions:

- Each pole (line to load terminal) with the circuit breaker open
- Each pair of line to line terminals with the circuit breaker closed
- Each line terminal to ground with the circuit breaker open

USCGC ALDER (WLB-225B) DOCKSIDE AVAILABILITY FY2020

- Each pole to ground with the circuit breaker closed

3.3.3.4 For each circuit breaker accessory, perform the applicable tests of ANSI/NEMA AB 4, Section 7.

3.3.3.5 Record the following data for each circuit breaker that was tested:

- Circuit breaker model and serial number
- Circuit identifier or position
- Test data and results
- Test technician name and date of test
- Name and address of testing laboratory

3.4 Reinstallation.

3.4.1 The Contractor shall reinstall and reconnect each circuit breaker using information retained in paragraph 3.2.1 above. Ensure that all pickup and time delay settings are returned to the values recorded prior to removal unless such conflict with data in Table 1. Place all reinstalled circuit breakers in the open or off position.

3.4.2 The Contractor shall perform an energized operational test of all affected circuit breakers in the presence of the Coast Guard Inspector. Verify that all accessory devices are functioning. For circuit breakers supplying three phase motor loads, either directly or indirectly through intermediate panelboards, perform a phase rotation check if any power wiring was disconnected.

3.4.3 The Contractor shall reconnect all cables disconnected in paragraph 3.2.1 above per SFLC Std Spec 3042 when isolation is no longer required.

4. NOTES

4.1 Renewal. Circuit breaker renewal is an acceptable alternative to the inspection and testing of this work item. Such may be more cost effective, especially for low amperage circuit breakers of small frame size.

4.2 In situ performance. For small frame devices and with appropriate portable test equipment, it may be possible to perform all required inspections and tests without removing the circuit breakers from the vessel.

4.3 Coordination. For cutters with insulated case, power, air, and/or vacuum circuit breakers, this work item is normally performed in conjunction with similar inspect and test work items for these types of devices.

USCGC ALDER (WLB-225B) DOCKSIDE AVAILABILITY FY2020

TABLE 1 – MOLDED CASE CIRCUIT BREAKER LIST (WLB225B)

FUNCTION	CIRCUIT	TRIP (A)	FRAME (A)	SPECIAL NOTES	MFR PART NO.	ACCESSORIES
		FREQ (Hz)	T _{CAL} (°C)			
Casualty Power Riser	1E-4EP-CP	250	250	Sourced from Emerg Gen feeder	Siemens FXD63M250	
		60	50			
No. 1 Fire Pump	1E-4EP-C (ALTN)	200	250		Siemens FXD63M200	
		60	50			
No. 2 Fire Pump	1E-4EP-A (NORM)	200	250		Siemens FXD63M200	
		60	50			
No. 1 Steering Gear HPU	1E-4EP-D (ALTN)	420 IT (setting #3)	125	Motor protector – inst trip only	Siemens ED63A050	Auxiliary Switch
		60	40			
No. 2 Steering Gear HPU	1E-4EP-B (NORM)	420 IT (setting #3)	125	Motor protector – inst trip only	Siemens ED63A050	Auxiliary Switch
		60	40			
MMR Vital Pwr Pnl P25	1E-4EP-(2-77-2) (ALTN)	125	125		Siemens ED63M125	
		60	50			
Submersible Pump Recep Pwr Pnl P21	1E-4EP-(1-21-3) (ALTN)	80	125		Siemens ED63M080	
		60	50			
Submersible Pump Recep Pwr Pnl P22	1E-4EP-(1-67-2) (ALTN)	100	125		Siemens ED63M100	
		60	50			
03 Level Vital Pwr Pnl P13	1E-4EP-(03-69-2)	60	125		Siemens ED63M060	
		60	50			
AMR Vital Pwr Pnl P30	1E-4EP-(2-86-1) (ALTN)	250	250		Siemens FXD63M250	
		60	50			
Port Boat Davit	1E-4EP-F	125	125		Siemens ED63M125	
		60	50			
1E Switchboard 120V Dist	1E-4EP-E	45	125		Siemens ED63M045	
		60	50			
Emer PH Elex Transformers	1E-4EP-H	45	125		Siemens ED63M045	
		60	50			
Emer Generator Radiator Fan	1E-4EP-I	15	125	Sourced from Emerg Gen feeder	Siemens ED63M015	
		60	50			
Spare	1E-4EP-*	250	250		Siemens FXD63M250	
		60	50			
Spare	1E-4EP-*	40	125		Siemens ED63M040	
		60	50			
1S-1E Bus Tie	1S-4P-1E	400	400		Siemens	

USCGC ALDER (WLB-225B) DOCKSIDE AVAILABILITY FY2020

FUNCTION	CIRCUIT	TRIP (A)	FRAME (A)	SPECIAL NOTES	MFR PART NO.	ACCESSORIES
		FREQ (Hz)	T _{CAL} (°C)			
		60	50		JXD63M400	
Casualty Power Riser	1S-4P-CP	250	250	Sourced from No. 1 SSDG feeder	Siemens FXD63M250	
		60	50			
MMR Vital Pwr Pnl P25	1S-4P-(2-77-2) (NORM)	125	125		Siemens ED63M125	
		60	50			
MMR Auxiliary Pwr Pnl P27	1S-4P-(2-66-3)	100	125		Siemens ED63M100	
		60	50			
AMR Vital Pwr Pnl P30	1S-4P-(2-86-1) (NORM)	250	250		Siemens FXD63M250	
		60	50			
03 Level Vital Pwr Pnl P13	1S-4P-(03-69-2)	60	125		Siemens ED63M060	
		60	50			
Auxiliary Pwr Pnl P26	1S-4P-(2-66-1)	200	250		Siemens FXD63M200	
		60	50			
Auxiliary Pwr Pnl P36	1S-4P-(2-87-1)	225	250		Siemens FXD63M225	
		60	50			
Auxiliary Pwr Pnl P37	1S-4P-(2-30-2)	150	250		Siemens FXD63M150	
		60	50			
Miscellaneous Pwr Pnl P10	1S-4P-(2-61-1)	50	125		Siemens ED63M050	
		60	50			
Miscellaneous Pwr Pnl P28	1S-4P-(1-95-2)	100	125		Siemens ED63M100	
		60	50			
Sub Pump Recep Pwr Pnl P21	1S-4P-(1-21-3) (NORM)	80	125		Siemens ED63M080	
		60	50			
Sub Pump Recep Pwr Pnl P22	1S-4P-(1-67-2) (NORM)	100	125		Siemens ED63M100	
		60	50			
Galley Pwr Pnl P24	1S-4P-(1-66-3)	200	250		Siemens FXD63M200	
		60	50			
Domestic Serv Pwr Pnl P11	1S-4P-(2-62-2)	150	250		Siemens FXD63M150	
		60	50			
Heater Pwr Pnl P3	1S-4P-(01-68-2)	200	250		Siemens FXD63M200	
		60	50			
Heater Pwr Pnl P4	1S-4P-(2-87-2)	100	125		Siemens ED63M100	
		60	50			
Heater Pwr Pnl P5	1S-4P-(2-66-5)	150	250		Siemens FXD63M150	
		60	50			
Heater Pwr Pnl P6	1S-4P-(1-25-1)	150	250		Siemens FXD63M150	
		60	50			

USCGC ALDER (WLB-225B) DOCKSIDE AVAILABILITY FY2020

FUNCTION	CIRCUIT	TRIP (A)	FRAME (A)	SPECIAL NOTES	MFR PART NO.	ACCESSORIES
		FREQ (Hz)	T _{CAL} (°C)			
Fan Coil Pwr Pnl P31	1S-4P-(02-75-2)	80	125		Siemens ED63M080	
		60	50			
Accommodation Vent Pwr Pnl P7	1S-4P-(1-78-2)	50	125		Siemens ED63M050	Undervoltage Trip
		60	50			
Vent Pwr Pnls P12 & P8	1S-4P-(1-62-2)	125	125		Siemens ED63M125	Undervoltage Trip
		60	50			
Heater Pwr Pnl P1	1S-4P-(03-67-4)	100	125		Siemens ED63M100	
		60	50			
No. 1 Fire Pump	1S-4P-C-(NORM)	200	250		Siemens FXD63M200	
		60	50			
No. 2 Fire Pump	1S-4P-A-(ALTN)	200	250		Siemens FXD63M200	
		60	50			
No. 1 Steering Gear HPU	1S-4P-D-(NORM)	420 IT (setting #3)	125	Motor protector – inst trip only	Siemens ED63A050	Auxiliary Switch
		60	40			
No. 2 Steering Gear HPU	1S-4P-B-(ALTN)	420 IT (setting #3)	125	Motor protector – inst trip only	Siemens ED63A050	Auxiliary Switch
		60	40			
Galley 240V Pwr Pnl P34	1S-4P-I	60	125		Siemens ED63M060	
		60	50			
1S SWBD 120V Dist	1S-4P-E	150	250		Siemens FXD63M150	
		60	50			
Main PH Elex Transformers	1S-4P-J	45	125		Siemens ED63M045	
		60	50			
Spare	1S-4P-*	250	250		Siemens FXD63M250	
		60	50			
Spare	1S-4P-*	200	250		Siemens FXD63M200	
		60	50			
Spare	1S-4P-*	150	250		Siemens FXD63M150	
		60	50			
Spare	1S-4P-*	100	125		Siemens ED63M100	
		60	50			
Spare	1S-4P-*	80	125		Siemens ED63M080	
		60	50			
Spare	1S-4P-*	50	125		Siemens ED63M050	
		60	50			
Spare	1S-4P-*	125	125		Siemens ED63M125	
		60	50			
Casualty Power	2S-4P-CP	250	250	Sourced from No.	Siemens	

USCGC ALDER (WLB-225B) DOCKSIDE AVAILABILITY FY2020

FUNCTION	CIRCUIT	TRIP (A)	FRAME (A)	SPECIAL NOTES	MFR PART NO.	ACCESSORIES
		FREQ (Hz)	T _{CAL} (°C)			
Riser		60	50	2 SSDG feeder	FXD63M250	
Spilled Oil Recovery HPU	2S-4P-G	225	250		Siemens FXD63M225	
		60	50			
No. 1 Aft Deck Mach HPU	2S-4P-B	100	250	If renewing, replace with FXD63M100	Siemens FXD63B100	
		60	50			
No. 2 Aft Deck Mach HPU	2S-4P-C	100	250	If renewing, replace with FXD63M100	Siemens FXD63B100	
		60	50			
Spare	2S-4P-*	400	400		Siemens JXD63M400	
		60	50			
Spare	2S-4P-*	350	400		Siemens JXD63M350	
		60	50			
Spare	2S-4P-*	250	250		Siemens FXD63M250	
		60	50			

WORK ITEM 22: Hull Fittings (Weight Handling Rigging Hardware), Inspect and Test

1. SCOPE

1.1 Intent. This work item describes the requirements for the Contractor to inspect and test designated hull fittings, listed in Table 1.

TABLE 1 - DESIGNATED ATON HULL FITTINGS

QTY	DESCRIPTION	LOCATION
4	Pad Eye and D-Ring, Flush Deck (S-A-S299)	Buoy Deck, 20'-9" Off CL, P/S
10	Pad Eye and D-Ring, Flush Deck (S-A-S299)	Buoy Deck, 19' Off CL, P/S
2	Pad Eye and D-Ring, Flush Deck (S-A-S299)	Buoy Deck, Frame 37, P/S
14	Pad Eye and D-Ring, Flush Deck (S-A-S299)	Buoy Deck, 15' Off CL, P/S
2	Pad Eye and D-Ring, Flush Deck (S-A-S299)	Buoy Deck, Frame 54, P/S
16	Pad Eye and D-Ring, Flush Deck (S-A-S299)	Buoy Deck, 108" Off CL, P/S
2	Pad Eye and D-Ring, Flush Deck (S-A-S299)	Buoy Deck, Frame 52, P/S
8	Pad Eye and D-Ring, Flush Deck (S-A-S299)	Buoy Deck, 36" Off CL, P/S
8	Pad Eye, Flush Deck (S-A S299)	Buoy Deck, 36" Off CL, P/S
10	Pad Eye, Flush Deck (S-A S299)	Cargo Hold, Frame 31, P/S
10	Pad Eye, Flush Deck (S-A S299)	Cargo Hold, Frame 33, P/S
10	Pad Eye, Flush Deck (S-A S299)	Cargo Hold, Frame 35, P/S
9	Pad Eye, Flush Deck (S-A S299)	Cargo Hold, Frame 37, P/S
36	D-Ring w/ Hold Down Strap (Austin 982-0046)	Cargo Hold, Bulkheads
6	Pad Eye, Flush Deck (S-A S299)	SORS Hold, Frame 41, P/S
6	Pad Eye, Flush Deck (S-A S299)	SORS Hold, Frame 43, P/S

USCGC ALDER (WLB-225B) DOCKSIDE AVAILABILITY FY2020

6	Pad Eye, Flush Deck (S-A S299)	SORS Hold, Frame 45, P/S
6	Pad Eye, Flush Deck (S-A S299)	SORS Hold, Frame 47, P/S

1.2 Government-furnished property.

None.

2. REFERENCES

COAST GUARD DRAWINGS

Coast Guard Drawing 225B WLB 573-11, Rev -, ATON Tie Downs

Coast Guard Drawing 225B WLB 672-001, Rev C, Storerooms, Cargo Stowage and Ship Store Arrangement and Details

COAST GUARD PUBLICATIONS

Surface Forces Logistics Center Standard Specification 0000 (SFLC Std Spec 0000), 2018, General Requirements

Surface Forces Logistics Center Standard Specification 5000 (SFLC Std Spec 5000), 2018, Auxiliary Machine Systems

Surface Forces Logistics Center Standard Specification 6310 (SFLC Std Spec 6310), 2018, Requirements for Preservation of Ship Structures

OTHER REFERENCES

None

3. REQUIREMENTS

3.1 General.

3.1.1 CIR.

None.

3.1.2 Tech Rep.

Not applicable.

3.1.3 Protective measures. The Contractor shall furnish and install all protective coverings to seal off and protect all non-affected vessel's components, equipment, and spaces near the work area against contamination during the performance of work. Upon completion of work, the Contractor shall remove all installed protective measures, inspect for the presence of contamination, and return all contaminated

USCGC ALDER (WLB-225B) DOCKSIDE AVAILABILITY FY2020

equipment, components, and spaces to original condition of cleanliness.

3.1.4 Interferences. The Contractor shall handle all interferences in accordance with SFLC Std Spec 0000, paragraph 3.3.5 (Interferences).

3.2 Inspection and test particulars. The Contractor shall accomplish the following for each hull fitting designated in paragraph 1.1, using Coast Guard Drawings 225B WLB 573-11 and 225 WLB 672-001, as guidance., and submit a CFR:

3.2.1 Visual inspection. Visually inspect all fittings for excessive damage, wear, corrosion, distortion, elongation of holes, gouges, pits, and cracks.

3.2.2 Measurements. Perform below measurement tasks and record percent wastage. Be aware that a 10% reduction in the original dimensions shall be cause for removal from service.

3.2.2.1 D-Ring. Using a suitable micrometer, measure the diameter (measurement A) at 90-degrees to the horizontal (top dead center). See Table 2 and the sketches provided in this work item as guidance, as applicable.

3.2.2.2 Flush deck tie-downs. Using a suitable micrometer, measure the diameter (measurement A) at center of bar of the S301 and S299 fittings. See Table 2 and the sketches provided in this work item as guidance, as applicable.

TABLE 2 - HULL FITTING MEASUREMENTS

MANUFACTURER	MODEL/MANUFAC. PART NUMBER		RING/BAR DIAMETER (MEASUREMENT A) (INCHES)
	DESIGNATOR	STRAP LENGTH (MEASUREMENT D) (INCHES)	
US Coast Guard	CGDR50T01	5.13	1.00
Schoellhorn-Albrecht	S113-50 (Generation 1)	5.0	1.00*
	S113-50 (Generation 2)	4.00	1.08
	S113-50 (Generation 3)	5.13	1.00
	S301		1.5
	S299		1.0
Peck and Hale	F654		0.91
Austin Hardware and Supply	982-0046		1.0

*D-Ring has a tapered cross section. Measurement is only valid in the vertical. See Sketch 1.

USCGC ALDER (WLB-225B) DOCKSIDE AVAILABILITY FY2020

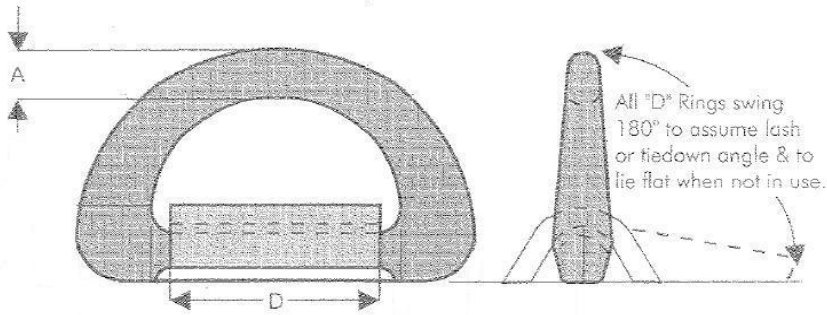

Sketch 1. Schoellhorn-Albrecht S113-50 (Generation 1) D-Ring and Strap.

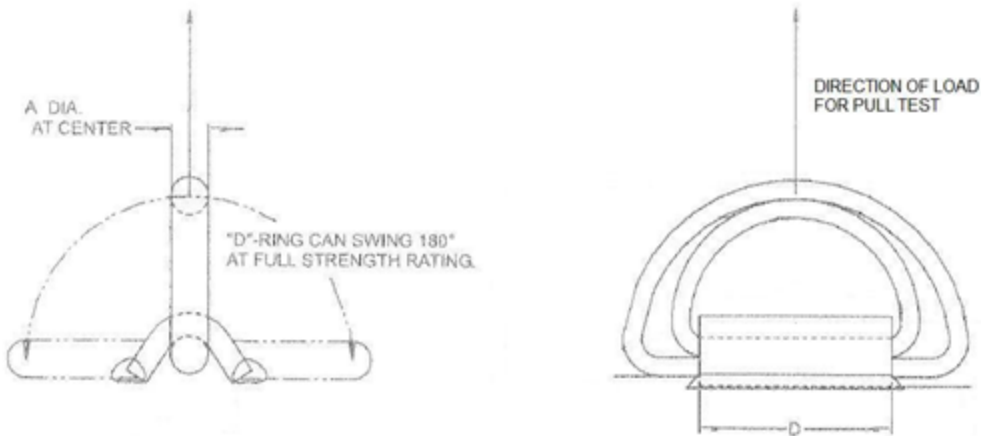

Sketch 2. Schoellhorn-Albrecht S113-50 (Generation 2 and 3) and Coast Guard CGDR50T01 D-Ring and Strap

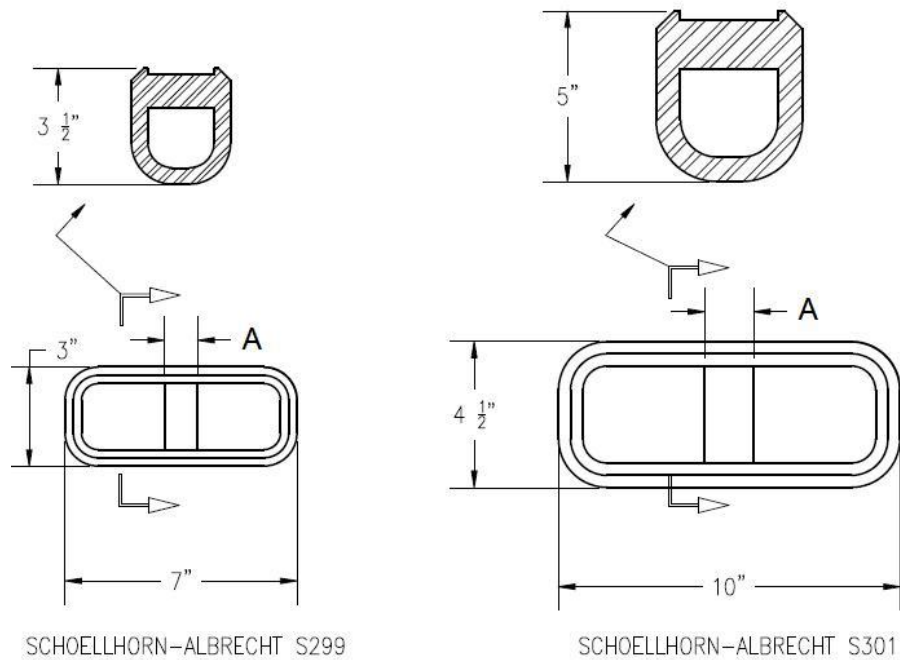

Sketch 3. Schoellhorn-Albrecht S299 and S301 Flush Deck Tie Downs.

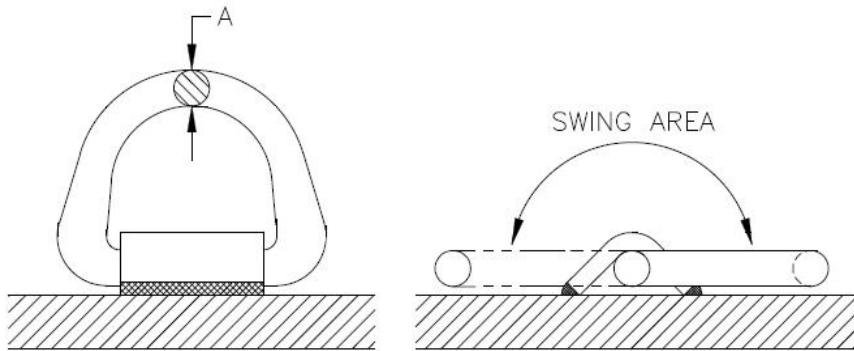

Sketch 4. Peck and Hale F187 D-Ring and Strap.

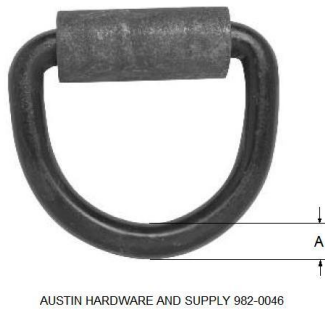

Sketch 5. Austin Hardware and Supply 982-0046 Heavy Duty Tie Down Rings with Clip.

3.2.3 Pull-test. Pull test all pad eyes and tie-downs in accordance with paragraph 3.2.7 (Pull test) of SFLC Std Spec 5000 , using Coast Guard Drawings 225B WLB 573-11 and 225 WLB 672-001, as guidance..

3.3 Touch-up preservation, general. The Contractor shall prepare and coat all new and disturbed exterior and interior surfaces, as applicable, to match existing adjacent surfaces in accordance with SFLC Std Spec 6310, paragraph 3.1.13 (Touch-ups and minor coating repairs.)

4. NOTES

This section is not applicable to this work item.

WORK ITEM 23: Sewage Holding Tank(s), Clean and Inspect

1. SCOPE

1.1 Intent. This work item describes the requirements for the Contractor to clean and inspect the following tank(s):

TABLE 1 – TANKS

TYPE OF TANK	LOCATION	CAPACITY - 95% (Gallons)	LOW SUCTION (Gallons)
Effluent Tank	4-48-0-W	21,402	111

1.2 Government-furnished property.

None.

2. REFERENCES Coast Guard Drawings

Coast Guard Drawing 225B WLB 593-001, Rev D, Sewage and Waste Water System Diagram

Coast Guard Drawing 225B WLB 593-009, Rev B, Sewage Holding Tank

COAST GUARD PUBLICATIONS

Surface Forces Logistics Center Standard Specification 0000 (SFLC Std Spec 0000), 2018,
 General Requirements

OTHER REFERENCES

ASTM International (ASTM) D1330, 2015, Standard Specification for Rubber Sheet Gaskets

3. REQUIREMENTS

3.1 General.

3.1.1 CIR.

USCGC ALDER (WLB-225B) DOCKSIDE AVAILABILITY FY2020

None.

3.1.2 Tech Rep.

Not applicable.

3.1.3 Protective measures. The Contractor shall furnish and install all protective coverings to seal off and protect all non-affected vessel's components, equipment, and spaces near the work area against contamination during the performance of work. Upon completion of work, the Contractor shall remove all installed protective measures, inspect for the presence of contamination, and return all contaminated equipment, components, and spaces to original condition of cleanliness.

3.1.3.1 Plug all inlet and outlet piping in the tank(s) to prevent contaminants from entering. Use plugs with an attached lanyard, ring or other system that will ensure plugs are not lost in the pipe openings.

3.1.4 Interferences. The Contractor shall handle all interferences in accordance with SFLC Std Spec 0000, paragraph 3.3.5 (Interferences). Known interferences include, but are not limited to the following:

- Piping.
- Pump(s).

3.1.5 Plug log. The Contractor shall keep a written record of all plugs put in any tank vents. A separate list shall be kept for each tank being entered.

3.1.5.1 Ensure that all plugs are removed from each tank upon completion of work in the tank.

3.1.5.2 The plug log shall be available to the Coast Guard Inspector when the inspector is performing his close-out inspection on each tank.

3.2 Operational test - initial. Prior to commencement of work, the Contractor shall witness Coast Guard personnel perform an operational pre-test to demonstrate all tank TLIs' existing operational condition. Submit a CFR.

3.3 Service disruption. When sewage collection service is disrupted due to contractor repairs, the Contractor shall refer to SFLC Standard Spec 0000 par 3.2.11 to provide required temporary facilities.

3.4 Cleaning and inspection requirements. The Contractor shall accomplish the following for the tank(s) listed in paragraph 1.1 (Intent), referring to Coast Guard drawings 225B WLB 593-001 and 225B WLB 593-009 for guidance:

3.4.1 Content removal. Remove and dispose of all contents, fluids, and/or residues in accordance with all applicable Federal, state, and local regulations

3.4.2 Cleaning requirements. Remove manhole cover(s). Clean all tank structure's interior surfaces free of all foreign materials, sediment, and sludge. Remove all persistent residues, taking care not to damage the tank coating system. Remove cleaning media and residues continuously from the tank during the washing process. Remove any residual wash media and wipe up residual moisture with clean lint-free cloths. Collect, contain, and dispose of all wash media, residues, and cleaning materials in accordance with all Federal, state, and local regulations. Clean all tank vent lines. Remove and clean the eductors and level switches inside of the tank(s). Reinstall the eductors and level switches upon completion of tank cleaning. Use new gaskets and o-rings to install/reinstall all removed/disturbed components.

USCGC ALDER (WLB-225B) DOCKSIDE AVAILABILITY FY2020

3.4.3 Inspection. Visually inspect all interior surfaces, including, but not limited to bulkheads, floor and overhead plating, structural members, manhole cover surfaces, fasteners and gasket seating surfaces. Submit a CFR including the following, as applicable:

- Tank structural condition.
- Inaccessible areas.
- Condition of tank coating, including measurements, percentage, location, and type of coating failure (not applicable for stainless steel tanks).
- Tank level indicator (TLI), vacuum and/or float switch condition.
- Suction and discharge piping and vent line condition.
- Fastener material (stainless steel) and condition.
- Zinc anode condition (remaining percentage).

3.4.4 Control panel assembly. Open and vacuum clean the control panel assembly. Inspect the control panel assembly for any indications of overheating or loose wiring or connections. Submit a CFR

3.5 Closing. The Contractor shall notify the COR at least 24 hours prior to closing the tank(s). After satisfactory inspection by the Coast Guard Inspector, and completion of all authorized repairs, close the manhole cover(s) with new gasket material conforming to ASTM D1330.

3.5.1 The Contractor shall renew 100% of nylon insert/nylock nuts and washers.

3.5.1 Chase threads on studs to ensure even installation of the access covers. Renew any damaged or missing fasteners. Existing undamaged fasteners may be reused. For purpose of bid, assume 10% of existing fasteners will require renewal. Renew all nylon insert nuts.

NOTE

Coast Guard personnel will operate all shipboard machinery and equipment.

3.6 Operational test – post repairs. After completion of work, the Contractor shall accomplish the following in the presence of the Coast Guard Inspector, and submit a CFR:

3.6.1 Adjust the set point on each of the vacuum pressure switches (as applicable) to the set points noted previously.

3.6.2 Verify operation of the low and high level switches/alarms and that the pumps cycle from lead to lag status during operation. Demonstrate proper operation of tank TLIs to prove satisfactory operating condition.

3.6.3 Upon completion of testing and, in the presence of the Coast Guard Inspector, pump tank(s) to the limit of the ship's installed pumps.

4. NOTES

4.1 *Atmospheric tank. The atmospheric sewage tank is a standalone tank and is not a part of the ship's structure.*

WORK ITEM 24: COVID-19 Prevention and Response Planning and Precautions, Perform

1. SCOPE

1.1 Intent. This work item describes the requirements for the Contractor to take special precautions to mitigate the risk of COVID-19 transmission from Contractor personnel to CG personnel through a COVID-19 Prevention and Response Plan.

1.2 Government-furnished property.

None.

2. REFERENCES

COAST GUARD DRAWINGS

None

COAST GUARD PUBLICATIONS

None

OTHER REFERENCES

Code of Federal Regulations (CFR) Title 29, Part 1910, Jul 2019, Occupational Safety and Health Standards

3. REQUIREMENTS

3.1 General. The Contractor shall perform the following to minimize transmission risk of the COVID-19 virus.

3.2 COVID-19 Prevention and Response Plan. Prior to the arrival conference, the Contractor shall submit their COVID-19 Prevention and Response Plan specific to this availability. Do not initiate work on a Coast Guard vessel or equipment without prior authorization and approval of the COVID-19 Prevention and Response Plan by the COR. The COVID-19 Prevention and Response Plan shall describe the Contractor's strategy to meet the requirements and contain the following elements:

3.2.1 Worker roster and travel plan. The Contractor shall establish and maintain a list of each contract worker, direct employee and subcontractor, who will be performing work or accessing the vessel during the period of performance. The list shall contain the following:

USCGC ALDER (WLB-225B) DOCKSIDE AVAILABILITY FY2020

- Name of contract employee
- List of CLIN/work-item numbers assigned to the employee for execution
- Whether the employees reside in a 50 mile local commuting distance of the contract performance site. Indicate other pertinent geographic location(s) associated with the employee travel during this contract and provide an explanation (e.g. employee's work on this contract will be intermittent and will include to temporary travel outside of the local commuting area)

3.2.1.1 The Contractor shall provide of the COVID-19 Prevention and Response Plan elements and the reporting requirements to all contracted worker, direct employee and subcontractor, using appropriate social distancing or remote meeting applications. Indicate on the roster that each worker received, understand and acknowledged the COVID-19 Prevention and Response Plan.

3.2.2 Daily screening of contract workers for symptoms. Once each workday and prior to working with Coast Guard personnel or equipment, the Contractor shall assess each contracted worker, direct employee and subcontractor for exposure to and symptoms of the COVID-19 virus. The assessment data of each employee shall be recorded daily in the Worker Roster and Travel Plan. The Contractor shall prohibit contracted worker, direct employees and subcontractors from working on CG vessels and equipment for two weeks if the reasonably determine the worker is carrying or infected with COVID-19. At a minimum, assess each employee as follows:

- Ask if the employee has been in contact with COVID-19 infected individuals or has been a part of any high-infection-risk situation (group gathering of over 10 people)
- Ask if the employee has immediate family members symptomatic and/or diagnosed
- Request self-reported COVID-19 symptoms exist (e.g. shortness of breath, fever, cough, diarrhea, loss of sense of taste or smell)
- Take the temperature of the employee, and report body temp outside normal range as defined by the National Institute of Health U.S. National Library of Medicine. Temperatures greater than 100°F+ indicate a fever.

NOTE

Normal body temperature varies by person, age, activity, and time of day. The average normal body temperature is generally accepted as 98.6°F (37°C). Some studies have shown that the "normal" body temperature can have a wide range, from 97°F (36.1°C) to 99°F (37.2°C).

A temperature over 100.4°F (38°C) most often means you have a fever caused by an infection or illness. Body temperature normally changes throughout the day. For additional information: National Institute of Health U.S. National Library of Medicine @ <https://medlineplus.gov/ency/article/001982.htm>

3.2.2.1 The Contractor must inform the COR immediately upon receiving notice that a worker who worked on the CG work site, or who interacted with CG personnel if,

- They have a fever
- Is suspected of having contracted COVID-19
- Has tested positive for COVID-19

3.2.2.2 The Contractor shall prohibit the worker from working on the CG vessel or with Coast Guard personnel or equipment for two weeks.

USCGC ALDER (WLB-225B) DOCKSIDE AVAILABILITY FY2020

3.2.3 Personal virus transmission control measures. All reasonable precautions that will reduce the probability of virus transmission shall be taken where it does not interfere with Industrial PPE required by CFR Title 29 1910. Additional control measures are required for all employees performing work onboard the vessel during the entire availability, to include but are not limited to:

- use of non-surgical cloth face masks/bandannas
- social distancing of greater than 6' whenever practicable
- regular hand washing
- arriving at the work site daily with freshly laundered clothing
- long sleeved clothing
- containment of coughs/sneezes
- use multiple shifts to decrease density of personnel
- schedule work flows to increase social distancing
- stagger lunch breaks
- maximize use of electronic communication in lieu of direct interaction

3.2.4 Install hygiene stations and promotion. Hand hygiene stations and CDC posters shall be temporarily installed for the duration of the contract as follows:

- Hand hygiene stations. At a minimum install a hand hygiene station at each point of ingress/egress to the vessel and in sufficient quantities and locations to allow easy and immediate access to the cleaning items.
- Hand hygiene stations shall consist of either a non-touch dispenser for hand sanitizer of at least 60% alcohol, or hand washing facilities with running water, foaming-soap, disposable towels and trash-receptacle.
- Hand hygiene stations shall be continuously maintained and resupplied throughout the work day so that all contract workers have continuous, uninterrupted accesses to cleaning items.
- CDC posters. Print, in English and Spanish or other appropriate native languages, the following CDC educational posters: "Stop the Spread of Germs" and "Wash Your Hands", "Symptoms of Coronavirus Disease 2019" and "Stay Home When You Are Sick!" At a minimum, they shall be prominently displayed at all hand hygiene stations and sanitary facilities.

NOTE

The CDC posters can be accessed through the following website:

<https://www.cdc.gov/coronavirus/2019-cov/communication/factsheets.html>

3.2.5 Cleaning and sanitization plan. After completing work for the day, in addition to normal worksite cleaning, all surfaces directly affected by contracted work (e.g. tables, door knobs and handles, light switches, toilets, sinks, railings, equipment being worked such as pumps/valves/etc.) shall be sanitized using an effective/EPA approved cleaner (e.g. diluted bleach, 60%+ alcohol solution, foaming detergents).

NOTE

The EPA suggested cleaners can be accessed through the following website:

<https://www.epa.gov/pesticide-registration/list-n-disinfectants-use-against-sars-cov-2>

3.3 Temporary Ventilation. The Contractor shall minimize use of recirculated air from shipboard HVAC systems to the greatest extent practicable. Prior to performing work, submit a CFR when temporary ventilation is required to execute work elsewhere in this contract. The Contractor shall install temporary ventilation that supplies from and returns air to the exterior of the vessel to prevent recirculation from interior compartments. Exhaust shall be routed to the vessel exterior at least 10 feet from any supply inlet. The Contractor may request the Coast Guard secure or reconfigure shipboard HVAC systems while performing work if possible.

4. NOTES

This section is not applicable to this work item.